

User Manual



EQ5500 Series

To prevent damage to the product caused by improper use, please carefully read this manual before operation.

Copyright © FOXESS CO., Ltd. All rights reserved.

No part of this document may be reproduced, copied, or distributed in any form or by any means without prior written authorization from the company.

Trademarks



and other Fox ESS trademarks are the property of FOXESS CO., Ltd.

All other trademarks or registered trademarks mentioned in this document belong to their respective owners.

Software License

Commercial use of any part or all of the firmware or software developed by the company is strictly prohibited.

Reverse engineering, decompilation, or any other actions that destroy the original design of the company's software are prohibited.

This document is intended as a usage guide only. All statements, information, and recommendations herein do not constitute any warranty, express or implied.

Due to product version updates or other reasons, the content of this document may be updated periodically. Please download the latest version from the official website if needed.

FOXESS CO., Ltd

Add:

No.939, Jinhai Third Road, New Airport Industry Area, Longwan District, Wenzhou, Zhejiang, China

Tel: 0510- 68092998

Postcode: 325024

WWW.FOX-ESS.COM

Version V1.0.0

Date 2026-05

Content

1 Notes on This Manual	2
2 Product Introduction	4
2.1 Battery Interface	5
2.2 Battery Function	6
3 Safety Precautions	8
3.1 Personnel Safety	8
3.2 Handling	9
3.3 Installation	9
3.4 Mounting	10
3.5 Response to Emergency Situations	11
4 Storage Requirement	12
5 Installation	13
5.1 Items in the package	13
5.2 Clearance	14
5.3 Tools	15
5.4 Installation Steps	15
5.5 Wiring Steps	19
5.6 Disassembly Steps	23
6 System Operation	24
6.1 System Start Up	24
6.2 System Shut Down	24
6.3 System Black Start	24
6.4 Monitoring Methods	25
7 Maintenance Guide	27
7.1 Routine Maintenance	27
7.2 Troubleshooting	28
7.3 FAQ	31
8 Product Specification	32
8.1 EQ5500-S Specifications	32
8.2 EQ5500-M Specifications	33
8.3 Battery System Specifications for EQ5500-Lx, (x=2~9)	33
9 Contact Us	35

1 Notes on This Manual

The document describes the installation, commissioning, maintenance and troubleshooting of the following high voltage battery listed below.

EQ5500 Series

The battery chemistry of these products is Lithium Iron Phosphate. This manual is designed for qualified personnel only. The tasks described in this document should be performed by authorized and qualified technicians only.

After Installation the Installer must explain the user manual to the end user.

All warranty-related information is subject to the product warranty documentation.

Symbols Used

The following symbols are used in the manual to highlight information in order to ensure the safety of the user's person and property when using the battery, and to use the battery more efficiently and optimally. The following symbols may appear in this manual, and the meanings they represent are listed below:

Danger!



"Danger" indicates a hazardous situation which, if not avoided, will result in death or serious injury.

Warning!

"Warning" indicates a hazardous situation which, if not avoided, could result in minor or moderate injury.

Note!

"Note" provides important tips and guidance.

Symbols	Explanation
	CE mark. The battery complies with the relevant EU directives.
	RCM mark.



The battery meets the requirements of the UK product safety certification.



Danger of high voltages.
Danger to life due to high voltages in the battery!



Do not place nor install near flammable or explosive materials.



Install the product out of reach of children.



Prohibit the use of water to extinguish fires.



Prohibition of private maintenance.



Prohibit Connector Reversal.



Read the manual before performing any operations on the battery.



Do not dispose of the product with household wastes.



Disconnect the equipment before carrying out maintenance or repair.



Observe precautions for handling electrostatic discharge sensitive devices.



PE conductor terminal.



Caution, risk of electric shock, energy storage timed discharge.

2 Product Introduction

EQ5500-S is the battery module, and EQ5500-M includes system controller and battery module. Ensure that each system has only 1 EQ5500-M and a maximum of 8 EQ5500-S.

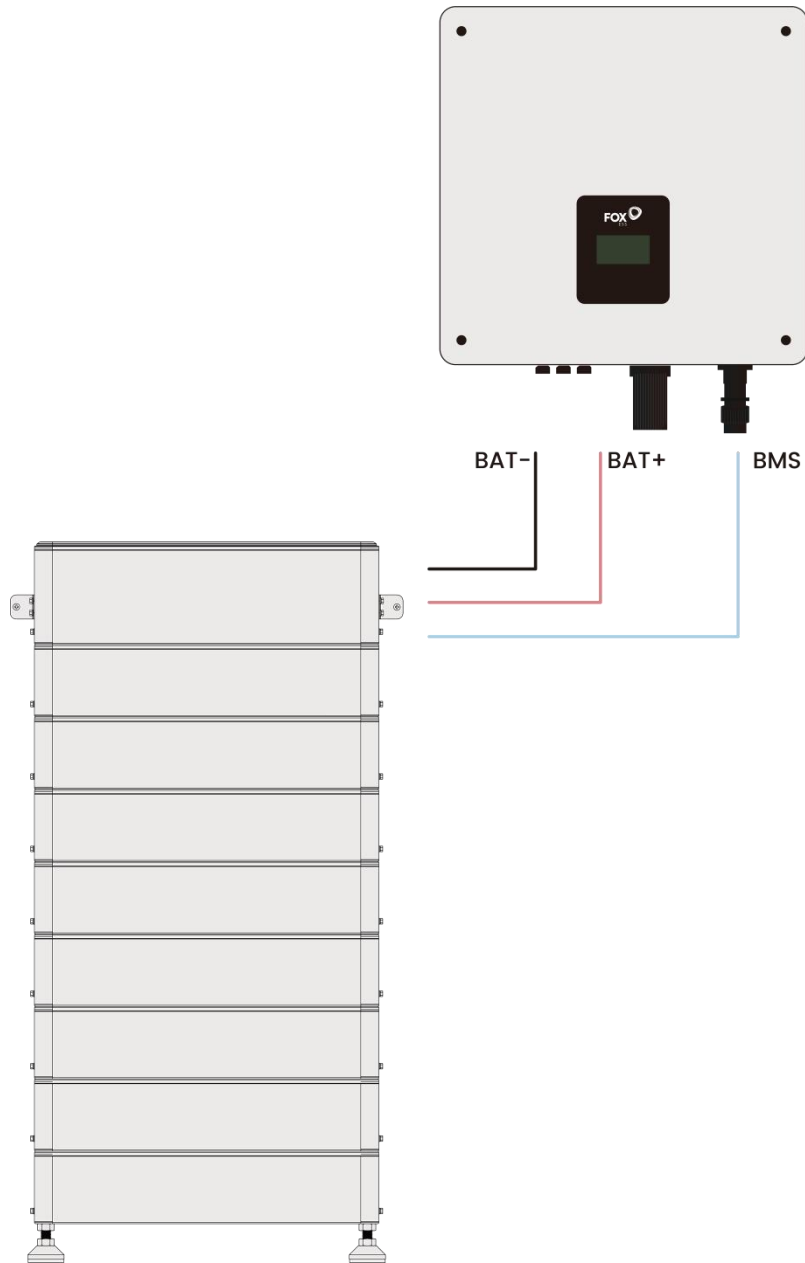

System diagram

Note!

The figure is for reference only, the actual configuration will depend on the specific project.

2.1 Battery Interface

The battery system contains the following Interface to allow it to connect and operate efficiently.

EQ5500-S:

- interface:

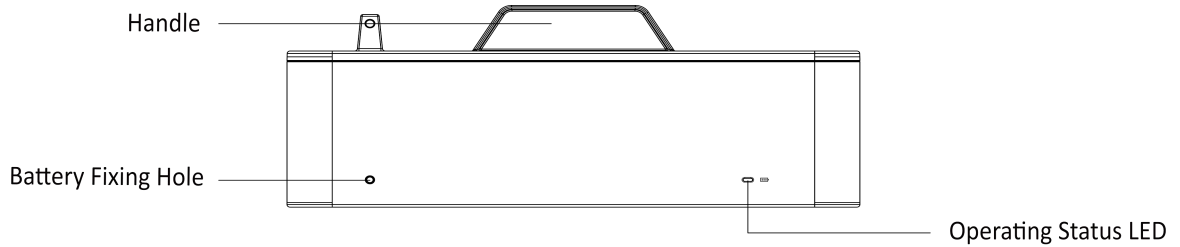

EQ5500-M:

- interface:

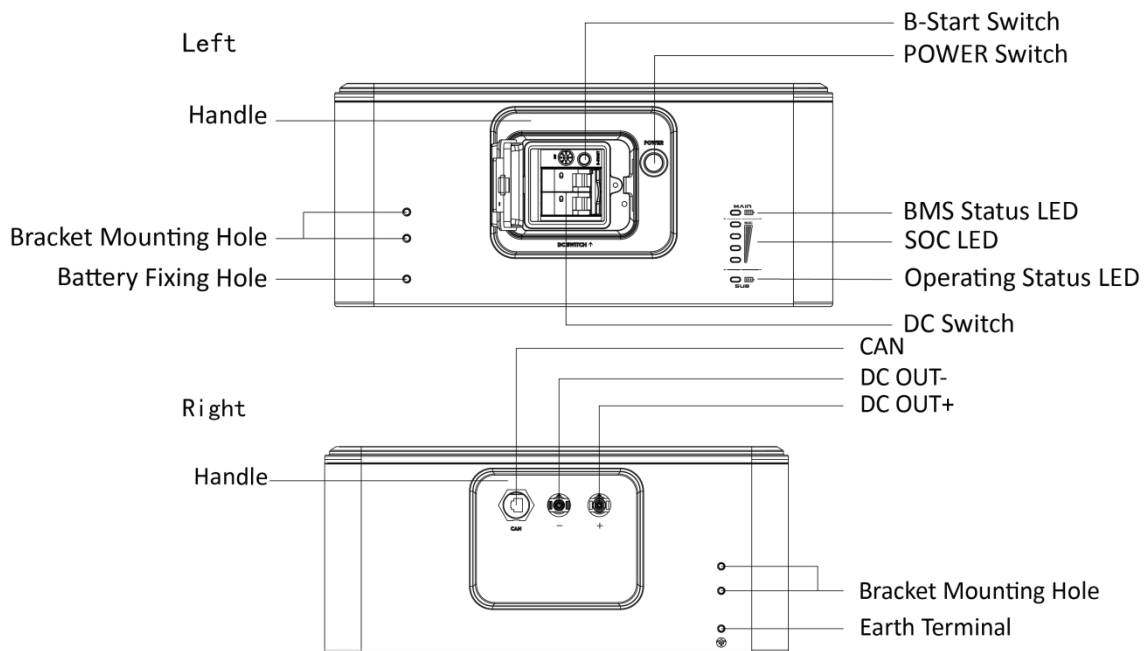

DC Switch

Power switch, battery charge and discharge circuit switch.

DC OUT +

Connect bat + of inverter.

DC OUT -

Connect bat - of inverter.

POWER Switch

System power on switch, press this switch, the system starts to work.

BMS Status LED and SOC LED

LED display specific alarm information and battery system power.

Operating status LED

This LED is used to indicate if the battery is operating effectively. A green light on this LED means the battery is ON and operating normally. If the battery is operating failure, a red light on this LED means the battery is operating abnormally.

2.2 Battery Function

2.2.1 Battery Protection Function

The batteries have been fitted with multiple protection systems to ensure the safe operation of the system. Some of the protection system includes:

- Inverter interface protection: Over Voltage, Over Current, External Short Circuit, Reverse Polarity, Ground Fault, Over Temp, In Rush Current.
- Battery protection: Internal Short Circuit, Over Voltage, Over Current, Over Temp, Under Voltage.

2.2.2 Fire Protection Function

Despite the extremely stable chemical properties of lithium iron phosphate batteries and the multiple protections, each battery unit is equipped with a fire protection module to further ensure the safety and reliability of Fox ESS batteries. This innovative module utilizes a new type of aerosol fire extinguishing device with features such as pressure-free storage, no maintenance required, high extinguishing efficiency, non-toxic and harmless characteristics.

Fire Extinguishing Mechanism

The fire extinguishing mechanisms of common agents mainly include isolation, smothering, cooling, and chemical suppression, with different agents exhibiting varying mechanisms. The fire extinguishing mechanism of thermal aerosols involves two main mechanisms: the cooling effect from endothermic decomposition and the chemical suppression effects in both gas and solid phases, which work synergistically. Additionally, the gaseous components in the batteries of the aerosol extinguishing agent also play a supportive role.

Cooling Fire Extinguishing Effect from Endothermic Decomposition

The cooling effect of thermal aerosol extinguishing agents is primarily due to the endothermic decomposition of metal oxides and carbonates. When a fire occurs, the solid particles in the aerosol rapidly absorb heat from the fire source, resulting in a decrease in flame temperature. This reduction minimizes the heat radiating to the burning surface and lowers the energy required to dissociate vaporized combustible materials into free radicals.

As a result, the combustion reaction is effectively suppressed.

Gas Phase Chemical Suppression Effect

Under thermal conditions, vaporized metal ions, such as strontium (Sr), potassium (K), and magnesium (Mg), exist as vapors and participate in multiple chain reactions with active combustion radicals including hydrogen ($\text{H}\cdot$), hydroxyl ($\cdot\text{OH}$), and oxygen ($\text{O}\cdot$). For example:

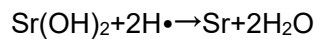
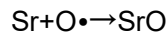
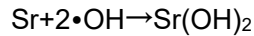

Through continuous action, this process consumes active combustion groups, significantly reducing their concentration and effectively suppressing combustion.

Solid Phase Chemical Suppression Effect

The solid particles in thermal aerosol extinguishing agents can adsorb intermediates such as $\cdot\text{OH}$, $\text{H}\cdot$, and $\text{O}\cdot$ from chain reactions, catalyzing their recombination into stable molecules. This interrupts the essential branching chain reactions in the combustion process. For example:

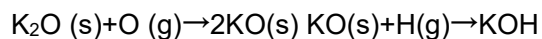

Technical Specifications

Activation method: Thermal activation

Thermal activation temperature: $\geq 170^\circ\text{C}$

Discharge time: ≤ 5 seconds

Danger!

Please contact Fox ESS for immediate replacement if the fire protection module is activated.

Non-professionals should not disassemble the battery without authorization.

Do not touch the device until the casing has cooled after the internal fire extinguisher has been activated to prevent burns.

For further assistance, please contact an authorized personnel or Fox ESS for further instructions.

3 Safety Precautions

3.1 Personnel Safety

Any work on the batteries should be handled by purchaser approved installer and hence it is understood that the purchaser approved installer should familiarize themselves with the contents of this manual before any maintenance or installation is carried out on the system.

Danger!

Operating Requirements

- High voltage exists inside the equipment. Unauthorized removal of necessary protective measures, improper use, and improper installation and operation may cause serious safety hazards, shock hazards, or equipment damage, and the resulting damage to the equipment is not covered by the warranty.
- Do not energize the equipment without completing the installation or without professional confirmation, and strictly prohibit operation with electricity.

Warning!

Operating Requirements

- Always use special insulated tools for wiring operations. Direct contact or contact with other conductors or indirect contact with the power supply equipment through wet objects is prohibited.
- During operation of the equipment, the enclosure temperature is high and there is a risk of burns. Before touching any part of the battery, make sure that the equipment and its surfaces are at a contact-safe temperature and voltage before proceeding.

Note!

Personnel requirements

- All operations, including transportation, installation, start-up and maintenance, must be performed by qualified and trained personnel.

3.2 Handling

- Do not expose battery to open flame.
- Store in a cool and dry place with ample ventilation.
- Do not store the battery near water sources.
- Store the battery on a flat surface.
- Recommend to store the battery out of reach of children and animals.
- Do not damage the unit by dropping, deforming, impacting, cutting or penetrating with a sharp object. It may cause leakage of electrolyte or fire.
- Do not touch any liquid spilled from the battery. There is a risk of electric shock or damage to skin.
- Always handle the battery wearing the insulated gloves.
- Do not step on the battery or place any foreign objects on it. This can result in damage.
- Do not charge or discharge damaged battery.

Warning: Do not use the battery if it has been dropped or appears compromised.

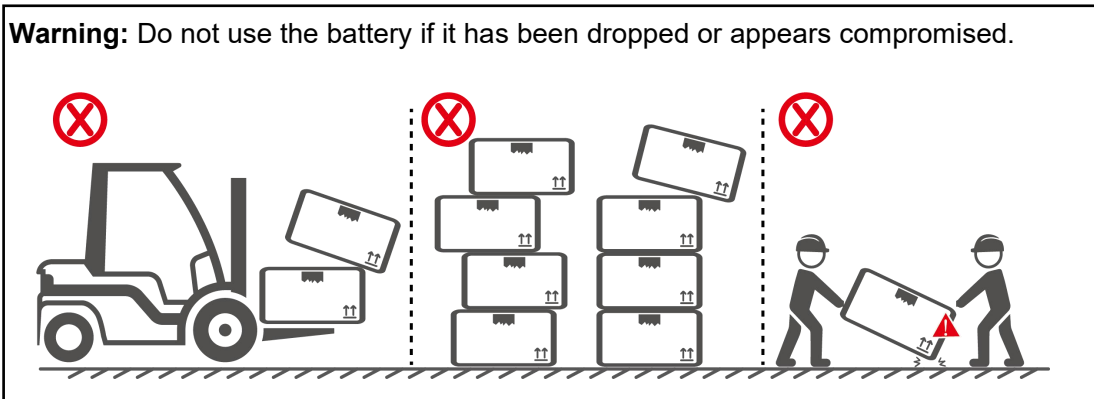

3.3 Installation

- Do not exceed the battery voltage rating of the inverter.
- Do not connect the battery to any incompatible inverter.
- Do not open the battery to repair or disassemble. Only Fox ESS is allowed to carry out any such repairs.
- In case of fire, use only dry powder fire extinguisher. Liquid extinguishers should not be used.
- Do not use battery in high static environment where the protection device might be damaged.
- Do not install with other batteries or cells.
- Please ensure on installation site that the deviation of voltages between new batteries and every single present battery is less than 0.5V.
- Recommend to check the new batteries mounted on-site comply to the warranty scope or have ever been re-charged within 5 months; on top of that, please make sure the SOC of present battery system onsite is $50\% \pm 5\%$.

3.4 Mounting

Make sure the installation site meets the following conditions.

- Ensure the installation area is protected from direct sunlight, rain, and snow accumulation, a shelter(e.g., rain canopy)is recommended.
- Keep the installation area away from high-temperature sources, flammable or explosive materials and other potential explosion hazards such as gas valves, LPG cylinders, heat pumps, firewood stacks, etc.
- The installation area must be completely waterproof, with a hard, level floor, and the wall should not have noticeable inclined angle.
- Maintain low and stable humidity with good ventilation; dust and dirt within the installation area must be minimized.
- Position the installation area away from television antennas or antenna cables to avoid lightning strikes and electromagnetic interference.
- Avoid the presence of flammable debris around the battery, such as cotton, fabric, haystacks, etc. which may be ignited by sparks and then lead the fire source to the battery, thus causing the battery to burn.
- Avoid the presence of hot or flammable objects around the battery, such as hydraulic bottles natural gas, oxygen, etc.), heat pumps and so on.

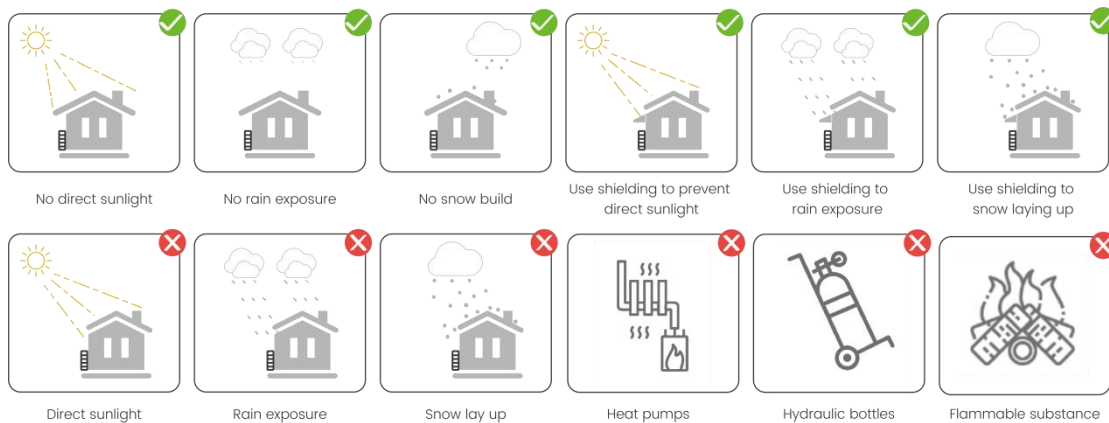

3.5 Response to Emergency Situations

The batteries comprise of multiple batteries connected in series. It is designed to prevent hazards or failures. However, Fox ESS cannot guarantee their absolute safety.

Under exposure to the internal materials of the battery the following recommendations should be carried out by the user.

- If there has been inhalation, please leave the contaminated area immediately and seek medical attention.
- If there has been contact with eyes, rinse the eyes with running water for 15 minutes and seek medical attention immediately.
- If there has been contact with the skin, wash the contacted area with soap thoroughly and seek medical attention immediately.
- If there has been ingestion, induce vomiting and seek medical attention.

Fire Situation

In situations where the battery is on fire, if it is safe to do so, disconnect the battery module by turn off the circuit breaker to shut off the power to the system. Use FM-200 or CO₂ fire extinguisher for the battery and an ABC fire extinguisher for the other parts of the system.

Under any fire situation, please evacuate the people from the building immediately before trying to extinguish it.

Water Situation

The battery modules are not water resistant. Hence care should be taken not to get it wet. If you find the battery completely or partially submerged in water do not try to open. Contact an authorized personnel or Fox ESS for further instructions.

4 Storage Requirement

- It is recommended that the battery storage time is not more than 6 months.
- For the first installation, the interval among manufacture dates of battery modules shall not exceed 3 months.
- Regularly check whether the service environment of the battery meets the requirements, and the installation position should be far away from the heat source.
- The battery module should be stored in an environment with a temperature range between -20°C~55°C, and charged regularly according to the table below with no more than 0.5 C(A C-rate is a measure of the rate at which a battery is discharged relative to its maximum capacity) to the SOC of 50% after a long time of storage.

Storage environment temperature	Relative humidity of the storage environment	Storage time	SOC
Below -20°C	/	Not allowed	/
-20~0°C	10%~90%	≤ 1 months	20%≤SOC≤50%
0~35°C	10%~90%	≤ 6 months	20%≤SOC≤50%
35~55°C	10%~90%	≤ 1 months	20%≤SOC≤50%
Above 55°C	/	Not allowed	/

Note: If the battery is stored over one year, 5%- 8% of the capacity may lose irreversibly.

Note!

If the battery is stored over one year, 5%- 8% of the capacity may lose irreversibly.

- Every year after installation. The connection of power connector, grounding point, power cable and screw are suggested to be checked. Make sure there is no loose, no broken, no corrosion at connection point. Check the installation environment such as dust, water, insect etc.

5 Installation

5.1 Items in the package

Note!

Please check if following items are including with the package. After unpacking, please check the product for damages and missing parts.

For EQ5500-S



A

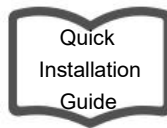

B

No.	Items
A	Mounting screw pack
B	Installation guide

For EQ5500-M



C

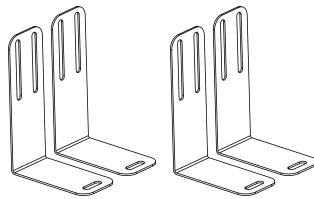

D

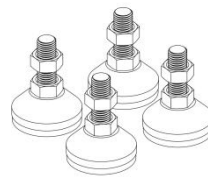

E

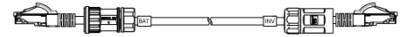

F



G

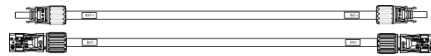

H



I



J

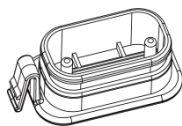

K



L

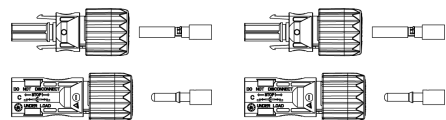

M

No.	Items	No.	Items
C	Mounting screw pack	I	Installation guide
D	Fixing bracket*2	J	Expansion tube*2 & Expansion screw*2
E	Footstand	K	Waterproof cover
F	Communication cable (BMS-Inverter)	L	Loosening tool
G	Grounding cable	M	Terminal PV*2
H	DC output cable		

5.2 Clearance

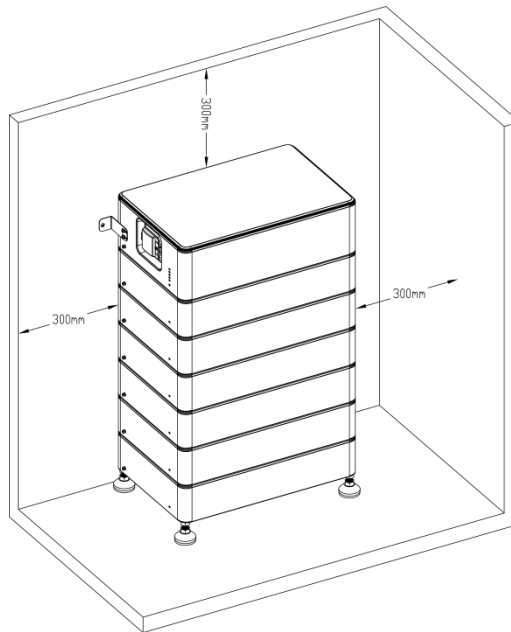

Note!

- The battery system can be installed indoors or outdoors.
- Make sure to leave a space of at least 300mm. A clearance of at least 300mm must be left around the battery module for proper cooling.
- Installation clearance requirements shall comply with local regulations.
- Make sure that the battery module is always exposed to the ambient air. The battery module is cooled by natural convection. If the battery module is entirely or partially covered or shielded, it may cause the battery module to stop operating.
- The safety clearance for equipment installation must comply with local regulations.
- For indoor installation scenarios, the installation area must be no less than 10 m².
- The battery system must be kept at least 2 meters away from heat sources.

5.3 Tools

The following tools will be required to install EQ5500-M and EQ5500-S.



6mm Magnetic
Phillips Screwdriver



Crimpers



Safety Shoes



Multimeter



Safety Gloves



Safety Glasses



Plier



Cable Ties



Hammer Drill
@φ8mm



Spirit Level



Tape



Marker

5.4 Installation Steps

⚠ Warning!

- Make sure that the inverter and battery is completely turned off before commencing installation.
- Do not connect different battery types together.

Procedures	
<p>Step 1</p>	<p>Install a EQ5500-S with four footstand (Item E) and place it on the ground and adjust it to the level. After installing the footstand, use a track level bar to confirm the level.</p>

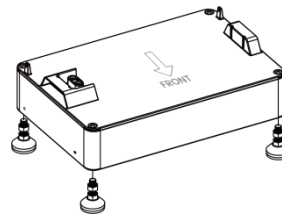

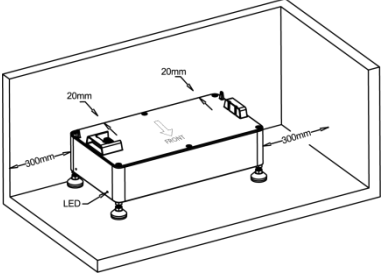
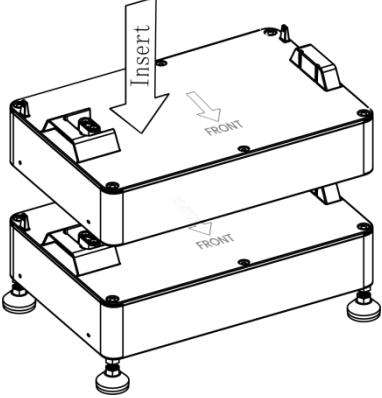
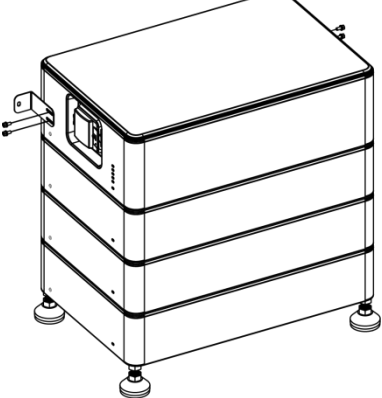
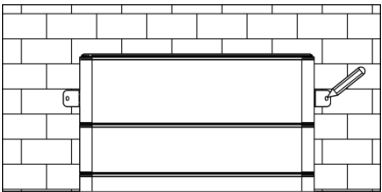
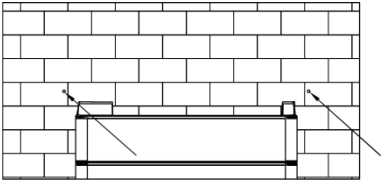
<p>Step 2</p>	<p>Place the battery 20mm against the wall.</p> <p>Note: Please make sure the Operating Status LED is on your left handside when you facing the battery model.</p>	
<p>Step 3</p>	<p>Stack the batteries one by one.</p>	
<p>Step 4</p>	<p>Place the two fixing brackets (Item D) close to the wall and install them on both sides of the battery.</p>	
<p>Step 5</p>	<p>Mark the wall through the bracket hole.</p>	
<p>Step 6</p>	<p>Punch after removing the EQ5500-M. Drill holes with electric drill, make sure the holes are at least 50mm deep, and then tighten the expansion tubes (Item J).</p>	

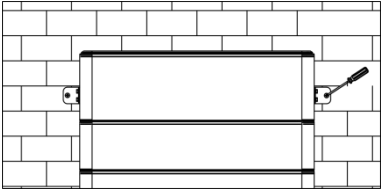
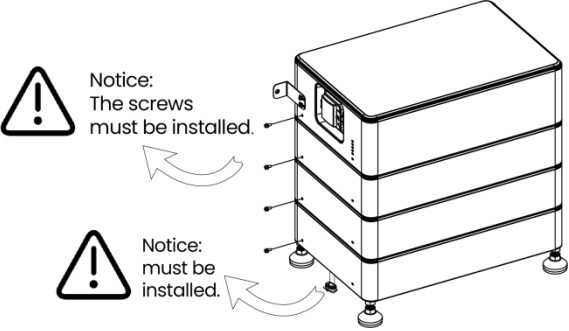
Step 7	After stacking EQ5500-M again, fix the battery on the wall.	
Step 8	Fix the mounting screw packs (Item C) on both sides of the battery. Insert the waterproof cover (Item K) into the bottom of the battery and lock it in place with the clip.	 <p>Notice: The screws must be installed.</p> <p>Notice: must be installed.</p>

Note!

Please make sure each system including 1 EQ5500-M and n EQ5500-S. EQ5500-S less than 8(1~8) pieces.

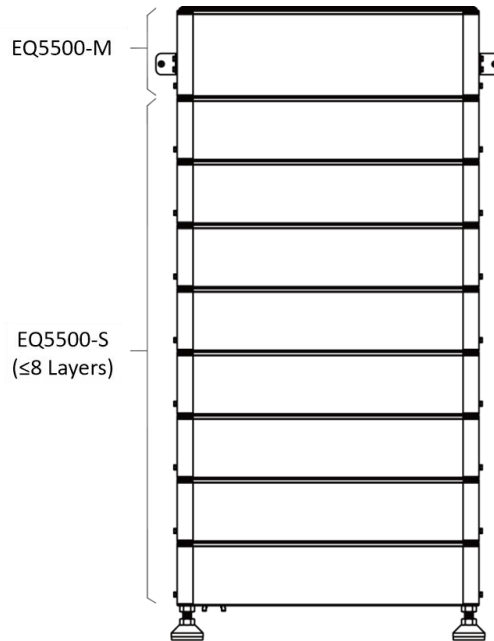
**Note!**

Installation Location Instructions for fixing brackets (Item D):

L : number of layers in the battery system.

- When $L \leq 6$, a pair of Item D is installed on EQ5500-M;
- When $L > 6$, a pair of Item D is installed on EQ5500-M, and install an additional pair of Item D in the middle layer of the EQ5500-S modules.

⚠ Warning!

When used with an inverter, the battery system voltage must meet the inverter battery port voltage range.

5.5 Wiring Steps

⚠ Warning!

Please use the side labeled BAT to connect to the battery and the side labeled INV to connect to the inverter.

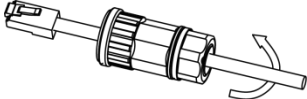
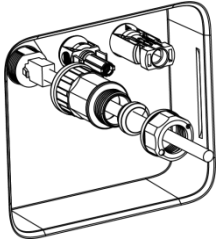
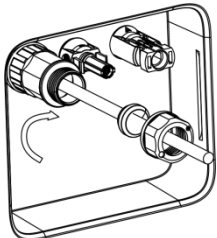
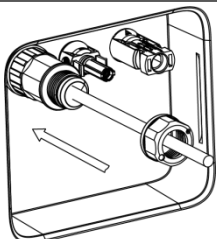
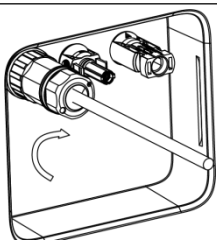
A. Communication cable installation procedure		
Step 1	Open the tail lock wire nut.	
Step 2	Plug communication cable RJ45 into the battery CAN port.	
Step 3	Use an open-end spanner to lock the body onto the RJ45 board end connector; torque: $1.2 \pm 0.2 \text{ N}\cdot\text{m}$.	
Step 4	Install the sealing plug into the main.	
Step 5	Use an open-end spanner to lock the thread locking nut onto the main body.	

⚠ Danger!

- Ensure that there is no short circuit of the terminals or with any external device.
- Do not connect the battery directly to inverter conductors or PV conductors. This will damage the battery and may result in explosion.

⚠ Warning!

- For the DC output cable, connect the end marked "DC+" and "DC-" to the battery, and connect the opposite end marked "BAT+" and "BAT-" to the inverter.
- Do not interchange the positive and negative terminals of the battery.

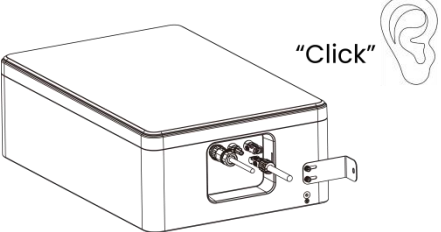
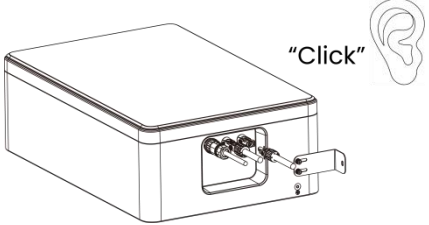
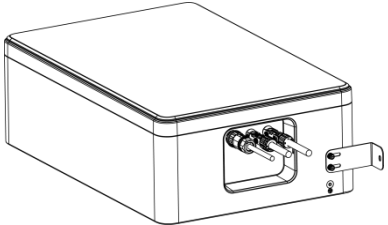
B. Power cable installation and fixing procedure		
Step 1	DC- output cable installation. Push until you hear a "click".	
Step 2	DC+ output cable installation. Push until you hear a "click".	
Step 3	DC output cable installation complete.	

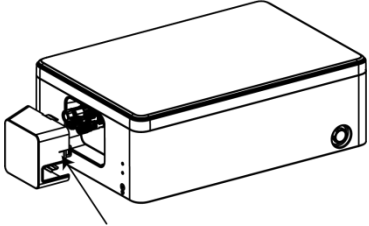
C. Protective cover installation procedure		
Step 1	Fit the buckle on the other side into the groove of the box. Then, press this buckle to insert it into the groove of the box.	

Insert the opposite ends of the DC output cable and the Communication cable into their corresponding BMS ports at the base of the inverter, then tighten securely.

Note!

Inverter wiring refer to the inverter user manual.

(Item F)

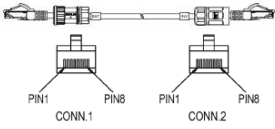

PIN ASSIGNMENTS
FRONT VIEW

CONN.1 PIN	CONN.2 PIN
1	1
2	2
3	3
4	4
5	5
6	6
7	7
8	8

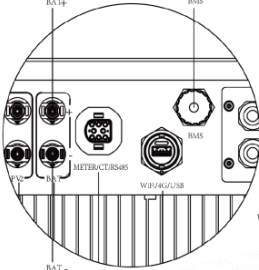

Note: Default wire harness PIN to PIN

PIN	Function Definitions
1	A-START
2	GND
3	RS485-B
4	BMS-CANL
5	BMS-CANH
6	BMS-CANH
7	BMS-CANL
8	RS485-A

Main-pack CAN port definition

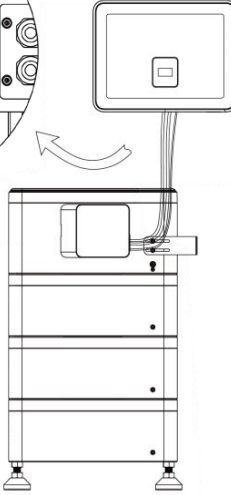

⚠ Warning!

Please ensure the reliability of the battery ground cable.

Connect the grounding cable. The figure is shown in below.

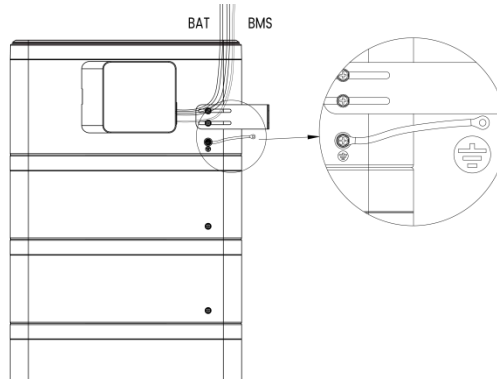
**⚠ Warning!**

Make sure that the power cable connected to the battery is connected vertically and that the vertical length is greater than 30mm. If the cable is bent close to the terminals, it may cause poor line contact and result in burnt terminals.

5.6 Disassembly Steps

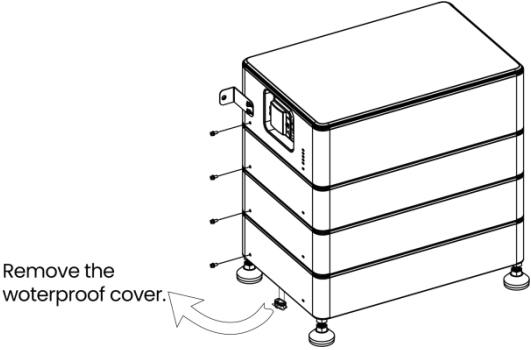
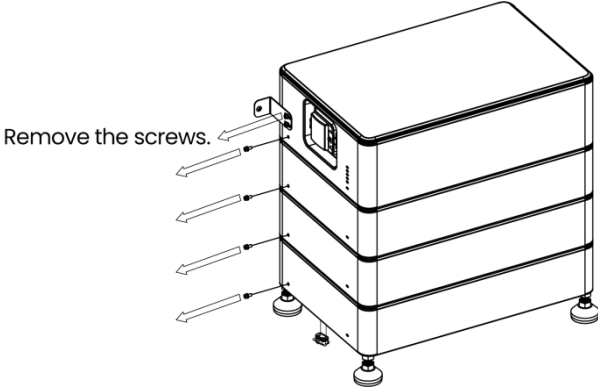
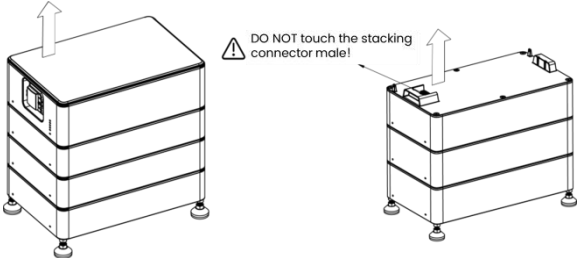
Procedures		
<p>Step 1</p>	<p>Shut down the battery system First turn off the POWER Switch, and then turn off the DC Switch, all LEDs are off when POWER Switch is turned off. After shutting down the system, there is no current flow between the support units. Then disconnect the wiring harness connected to the inverter.</p>	
<p>Step 2</p>	<p>Remove the waterproof cover.</p>	 <p>Remove the waterproof cover.</p>
<p>Step 3</p>	<p>Remove the screws.</p>	 <p>Remove the screws.</p>
<p>Step 4</p>	<p>Remove the EQ5500-M and EQ5500-S, and store them properly.</p>	 <p>DO NOT touch the stacking connector male!</p>

6 System Operation

- When the grid connected system is started, the inverter should be turned on first to avoid the current pulse of the inverter increasing to the battery module.
- All installation and operation must comply with local electrical standards.
- Check all power cables and communication cables carefully.

6.1 System Start Up

First turn on DC Switch and then press the POWER Switch, firstly main battery LED will light up once, and then the BMS Status LED will light up for 0.5s, Operating Status LED will light up for 1s at the same time, it means that the system works normally.

6.2 System Shut Down

First turn off the POWER Switch, and then turn off the DC Switch, all LEDs are off when POWER Switch is turned off.

After shutting down the system, there is no current flow between the support units.

6.3 System Black Start

Under special circumstances when both PV and Grid power are out of order, the battery can be activated through the "Black Start" function. This means that our energy storage inverter and battery can continue to operate. The startup steps for Black Start are as follows:

- First turn on DC Switch and then press the POWER Switch.
- Please press and hold the B-Start Switch for 5 seconds. (Complete within 30 seconds after the battery system starts up).
- The Status LED remains solid green, indicating successful activation of Black Start mode.

Warning!

Ensure correct battery-inverter connection prior to Black Start. No wiring modifications during black start.

6.4 Monitoring Methods

Once the system has been successfully installed and commissioned, communication between the battery and the inverter is functioning correctly, and the battery can be monitored and controlled by the inverter. End users can view the monitoring page via the FoxCloud APP or the FoxCloud Web platform.

Battery system cable layout diagram

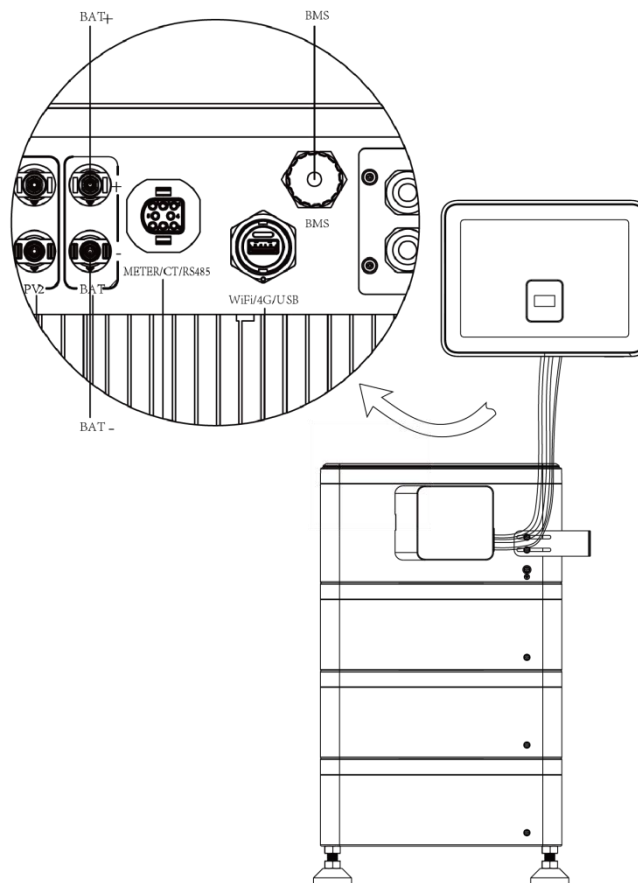

Note!

- Detailed information about the FoxCloud APP, please refer to the 《FoxCloud APP User Manual》.
- Detailed information about the FoxCloud Web platform, please refer to the relevant inverter manual.
- Terminal layout may vary between different inverters; the diagram above is for reference only. The actual wiring should be carried out in accordance with the manual for the specific inverter being used.

FoxCloud APP interface example

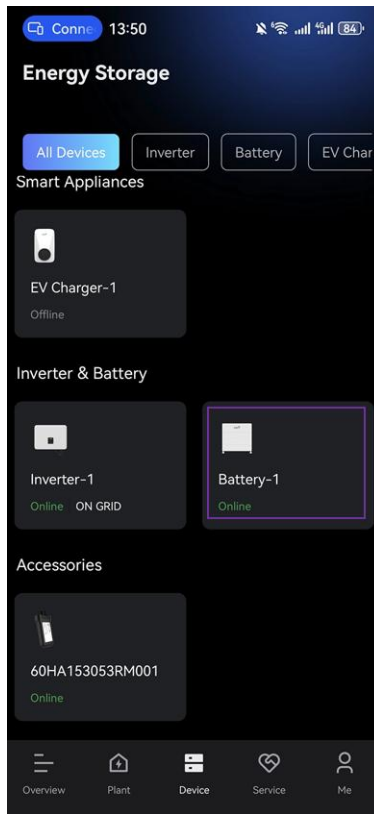

FoxCloud Web platform interface example

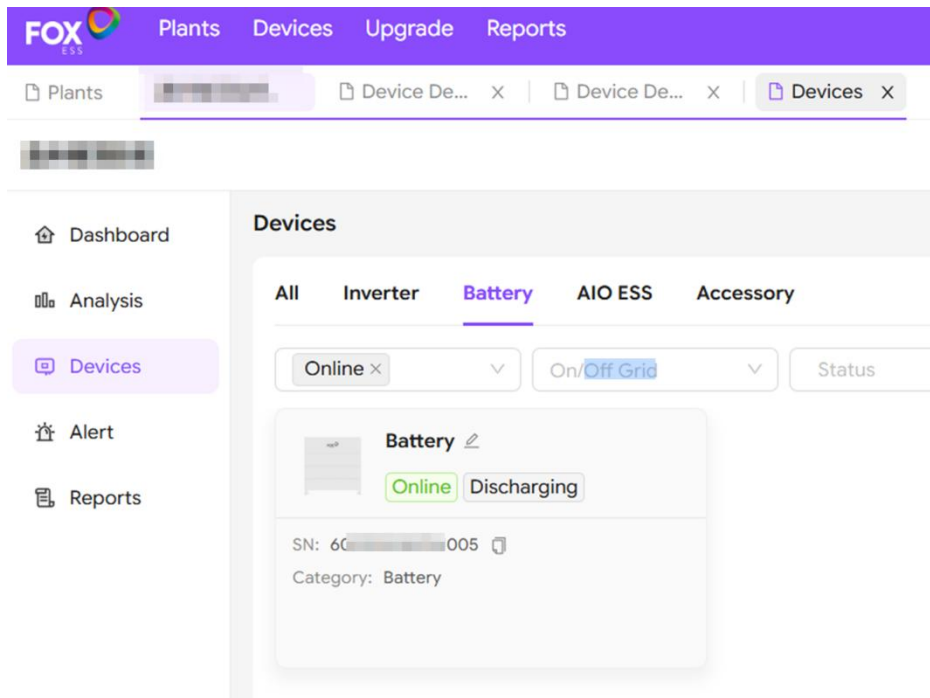

Note!

The equipment details shown in the above images above are for reference only.

7 Maintenance Guide

7.1 Routine Maintenance

Note!

- To ensure long-term accuracy of the State of Charge (SOC), it is recommended to perform a full SOC calibration at regular intervals (for example, every two weeks).
- This calibration is completed by charging the battery until the charging power reaches zero, allowing the system to correctly re-align the SOC reference.

Warning!

- Before performing any cleaning work, disconnect the system from all power sources.
- Clean the housing, cover, and display using a soft, dry cloth only.

To guarantee stable and reliable operation over the system's service life, it is strongly recommended to carry out routine maintenance checks as described in this section.

Check Items	Acceptance Criteria	Maintenance Interval
Battery cleanliness	The battery is free of dust and obstructions, ensuring proper heat dissipation.	Every 6~12 months
Battery visible damage	The battery shows no signs of damage or deformation.	Every 6 months
Battery operating status	<ol style="list-style-type: none"> 1. The battery operates without abnormal noise. 2. All system parameters are correctly configured. This maintenance should be performed while the battery is running. 	Every 6 months
Electrical connections	<ol style="list-style-type: none"> 1. All cables are securely connected. 2. Cables are intact; in particular, cable jackets in contact with metallic surfaces show no scratches or damage. 3. Unused cable glands are sealed with rubber plugs and properly secured with pressure caps. 	Perform the first inspection 6 months after initial commissioning. Thereafter, every 6~12 months.

7.2 Troubleshooting

When the red / green LED on the panel is flashing or normally on, it does not mean that the EQ is abnormal, it may be just an alarm or protection. Please check the “LED status indicators” for the detailed faulty definition before any troubleshooting steps. In general, the alarm indication is normal without manual intervention. When the alarm triggering state is removed, EQ will automatically return to normal use.

Problem determination based on the following points:

- Check if the red indicator light illuminates once the battery enters operation;
- Whether the buzzer in EQ5500-M on;
- Whether the battery system can be communicated with inverter;
- Whether the battery can be output voltage or not.

Preliminary determination steps

Battery system cannot work, when DC switch on and POWER on, the LED doesn't light up or flash, please contact the local distributor.

- The LED display of EQ5500-M and EQ5500-S is normal, but it cannot charge and discharge. Observe the display screen of inverter and there is no SOC. Please check whether the CAN communication between EQ5500-M to inverter is well connected. If the connection is good, please replace a CAN communication cable. If the SOC is still not visible on the inverter display screen, please contact the local distributor.
- After the battery system is powered on, if you can see the alarm information on the LED and inverter display screen at the same time, please contact the local distributor.

7.2.1 LED Indicators

The operating status light on the left side of the battery module shows its working status.

For EQ5500-S

Green LED	Red LED	Batteries Status
On for 0.5s, Off for 0.5s	On for 0.5s, Off for 0.5s	Running in boot
On for 0.1s, Off for 0.1s	On for 0.1s, Off for 0.1s	Upgrading
On for 1s, Off for 1s	Off	Normal Working
Off	On for 1s, Off for 1s	Alarm

For EQ5500-M

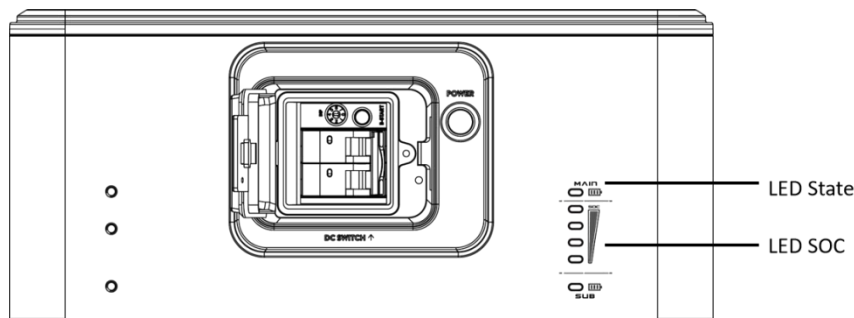

SOC	System Status	LED State	LED SOC			
=100%	Standby	■	●	●	●	●
100% > SOC >= 75%		■	●	●	●	●
75% > SOC >= 50%		■	/	●	●	●
50% > SOC >= 25%		■	/	/	●	●
25% > SOC >= 0%		■	/	/	/	●
=100%	Discharge	●	●	●	●	●
100% > SOC >= 75%		●	●	●	●	●
75% > SOC >= 50%		●	/	●	●	●
50% > SOC >= 25%		●	/	/	●	●
25% > SOC >= 0%		●	/	/	/	●
=100%	Charge	●	■	■	■	■
100% > SOC >= 75%		●	■	■	■	■
75% > SOC >= 50%		●	/	■	■	■
50% > SOC >= 25%		●	/	/	■	■
25% > SOC >= 0%		●	/	/	/	■

7.2.2 Fault Indicators

Fault	LED State	LED SOC			
Under voltage fault	■	/	/	/	●
Over voltage fault	■	/	/	●	/
Over temperature fault	■	/	/	●	●
Under temperature fault	■	/	●	/	/
Discharge over current	■	/	●	/	●
Charge over current	■	/	●	●	/
Reserve	■	●	/	/	/
Pre-Charge failed	■	●	/	/	●
Short circuit Protection	■	●	/	●	/
AFE communication failed	■	●	/	●	●
Module Addressing failed	■	●	●	/	/
IVU Communication failed	■	●	●	/	●
BMU Communication failed	■	●	●	●	/
PCS Communication failed	■	●	●	●	●
HVB FUSE fault	●	/	/	/	●
Module FUSE fault	●	/	/	●	/
Module matching fault	●	/	/	●	●
Internal total voltage sampling failed	●	/	●	/	/
Temperature sampling failed	●	/	●	/	●
Relay adhesion	●	/	●	●	/

Relay Not Close	●	/	●	●	●
Relay drive failed	●	●	/	/	/
Single Cell "0V" fault	●	●	/	/	●
Temperature high permanent failed	●	●	/	●	/
The Single voltage high permanently failed	●	●	/	●	●
SOH low protection	●	●	●	/	/
AFE failed (UV/OV/UT/OT)	●	●	●	/	●
Shutdown failed	●	●	●	●	/
Other fault	●	●	●	●	●

Remark:

■: LED flash display (on: 0.5s, off: 0.5s)

●: LED on display

7.3 FAQ

7.3.1 Expanded capacity requirement

If a battery is replaced or added for capacity expansion, each battery's SOC should be consistent. The max. SOC difference should be between $\pm 5\%$.

If users want to increase their battery system capacity, please ensure that the SOC of the existing system capacity is about 50%. The manufacturer date of the new battery shall not exceed 12 months; in case of exceeding 12 months, please charge the new battery to around 50%.

7.3.2 Storage with Low SOC

After the battery is powered off, static power consumption and self-discharge loss may occur in internal modules. Therefore, charge batteries in a timely manner and do not store the battery in low SOC. Otherwise, the battery may be damaged due to overdischarge, and battery modules need to be replaced.

Storage in low SOC may occur in the following scenarios:

- The DC SWITCH on the power control module is OFF.
- The power cables or signal cables are not connected.
- The batteries cannot be charged due to a system fault after discharge.
- The batteries cannot be charged due to incorrect configurations in the system.
- The batteries cannot be charged due to no PV input and long-term mains failure.

Regardless of scenarios, the batteries must be charged within the longest interval corresponding to the SOC when the batteries are powered off. If the batteries are not charged within the specified interval, they may be damaged due to overdischarge.

Storage environment temperature	Power-Off SOC Before Storage	Maximum Charge Interval
0~35°C	0% ≤ SOC < 5%	7 days

Note!

When the battery SOC decreases to 0%, charge the batteries within 7 days. Permanent battery faults caused by delayed charge due to customer reasons are beyond the warranty scope.

7.3.3 Low-Temperature Battery Reserve

To prevent battery drain and potential damage in freezing weather, the system includes an automatic low-temperature protection feature. It proactively manages the battery to maintain adequate charge, extending standby time when temperatures drop.

8 Product Specification









8.1 EQ5500-S Specifications

Specifications for EQ5500-S	
Model No.	EQ5500-S
Max. charge/discharge current (A)	50
Operating temperature (°C)	Charge: 0~55 Discharge: -10~55
Storage temperature (°C)	-10~35 (Recommended)
Humidity (%)	5~95 (No Condensing)
Normal voltage (V)	44.8
Normal capacity (Ah)	122
Normal energy (kWh)	5.46
Battery voltage range (V)	40.6~51.1
Max. Continuous discharge/charge current (A)	50/50
Short circuit current (kA)	2.6
(CC-CV) Standard charging current (A)	50
Constant current and voltage charging cut-off current (A)	2.0
Depth of discharge(%)	100
Peak discharge current (60s) (A)	65
Altitude (m)	≤3000
Dimensions (W*H*D) (mm)	570*172*380
Weight (kg)	41±5%
Communication interfaces	CAN

8.2 EQ5500-M Specifications

Specifications for EQ5500-M	
Model No.	EQ5500-M
Max. charge/discharge current (A)	50
Operating temperature (°C)	Charge: 0~55 Discharge: -10~55
Storage temperature (°C)	-10~35 (Recommended)
Humidity (%)	5~95 (No Condensing)
Normal voltage (V)	44.8
Normal capacity (Ah)	122
Normal energy (kWh)	5.46
Battery voltage range (V)	40.6~51.1
Max. Continuous discharge/charge current (A)	50/50
Short circuit current (kA)	2.6
(CC-CV) Standard charging current (A)	50
Constant current and voltage charging cut-off current (A)	2.0
Depth of discharge(%)	100
Peak discharge current (60s) (A)	65
Altitude (m)	≤3000
Dimensions (W*H*D) (mm)	570*188*380
Weight (kg)	44±5%
Communication interfaces	CAN

8.3 Battery System Specifications for EQ5500-Lx, (x=2~9)

Specifications for EQ5500								
Model No.	EQ5500-L2	EQ5500-L3	EQ5500-L4	EQ5500-L5	EQ5500-L6	EQ5500-L7	EQ5500-L8	EQ5500-L9
Technical Properties								
Battery designation	IFpP53/150/ 120[(14S)2S] E/-10+50/90	IFpP53/150/ 120[(14S)3S] E/-10+50/90	IFpP53/150/1 20[(14S)4S]E /-10+50/90	IFpP53/150/ 120[(14S)5S]]E/-10+50/90	IFpP53/150/1 20[(14S)6S]E /-10+50/90	IFpP53/150 /120[(14S) 7S]E/-10+5 0/90	IFpP53/150 /120[(14S)8 S]E/-10+50 /90	IFpP53/15 0/120[(14S)9S]E/-1 0+50/90
The number of batteries	1EQ5500-M+ 1EQ5500-S	1EQ5500-M +2EQ5500-S	1EQ5500-M+ 3EQ5500-S	1EQ5500-M +4EQ5500-S	1EQ5500-M+ 5EQ5500-S	1EQ5500- M+6EQ550 0-S	1EQ5500- M+7EQ550 0-S	1EQ5500- M+8EQ550 0-S
Nominal voltage (V)	89.6	134.4	179.2	224.0	268.8	313.6	358.4	403.2
Nominal capacity (Ah)	122	122	122	122	122	122	122	122
Nominal energy	10.92	16.38	21.84	27.30	32.76	38.22	43.68	49.14

(kWh)								
Battery voltage range (V)	81.2~102.2	121.8~153.3	162.4~204.4	203.0~255.5	243.6~306.6	284.2~357.7	324.8~408.8	365.4~459.9
Max. charge/discharge current (A)	50/50							
(CC-CV) Standard charging current (A)	50							
Constant current and constant voltage charging cut-off current (A)	2.0							
Peak discharge Current (60s) (A)	65							
Depth of discharge(%)	100							
Storage temperature (°C)	-10~35 (Recommended)							
Operating charge/discharge temperature (°C)	Charge: 0~55 Discharge: -10~55							
Discharge capacity (Ah)	97@-20±2°C @1/3C ; 122@25±2°C @1C; 122@55±2°C @1C							
Ingress protection	IP65							
Protective class	Class I							
Dimensions (W*H*D) (mm)	570*386*380	570*524*380	570*662*380	570*800*380	570*938*380	570*1076*380	570*1214*380	570*1352*380
Weight (kg)(±5%)	85	126	167	208	249	290	331	372
Communication interfaces	CAN							

9 Contact Us

If you have any questions about the product, please contact us:

- Fox ESS Headquarters: No.939, Jinhai Third Road, New Airport Industry Area, Longwan District, Wenzhou, Zhejiang, China.
- Wuxi R&D Center: No. 37 Huaqing Avenue, Wuxi Economic Development Zone (Intersection of Huaqing Avenue and Huayun Road)
- Wuhan R&D Center: 6th Floor, Block A, Tower T4, CHINA PROCUREMENT CENTER, No. 789 Gaoxin Avenue, East Lake New Technology Development Zone, Wuhan City, Hubei Province, P.R. China
- Shanghai R&D Center: No.1255, Jinhai Road, Pudong New Area, Shanghai, China
- After-Sales Service Hotline: 400 1888 900
- Contact Telephone (Wenzhou): 0577-88159999
- Contact Telephone (Wuxi): 0510-68092998
- Contact Us: info@fox-ess.com
- Contact Us (EV Charger): ev@fox-ess.com
- After-Sales Service: service@fox-ess.com