

# User Manual



## Stackable AIO

THREE-PHASE HYBRID/AC

---

To prevent damage to the product caused by improper use, please carefully read this manual before operation.

**Copyright © FOXESS CO., Ltd. All rights reserved.**

No part of this document may be reproduced, copied, or distributed in any form or by any means without prior written authorization from the company.

### **Trademarks**



and other Fox ESS trademarks are the property of FOXESS CO., Ltd.

All other trademarks or registered trademarks mentioned in this document belong to their respective owners.

### **Software License**

Commercial use of any part or all of the firmware or software developed by the company is strictly prohibited.

Reverse engineering, decompilation, or any other actions that destroy the original design of the company's software are prohibited.

This document is intended as a usage guide only. All statements, information, and recommendations herein do not constitute any warranty, express or implied.

Due to product version updates or other reasons, the content of this document may be updated periodically. Please download the latest version from the official website if needed.

## **FOXESS CO., Ltd**

Add:

No.939, Jinhai Third Road, New Airport Industry Area, Longwan District, Wenzhou, Zhejiang, China

Tel: 0510- 68092998

Postcode: 325024

[WWW.FOX-ESS.COM](http://WWW.FOX-ESS.COM)

Version V1.0.0

Date 2026-04

# Content

---

1 Notes on This Manual .....	1
1.1 Scope of Validity .....	1
1.2 Target Group .....	6
1.3 Symbols Used .....	6
2 Safety Precautions .....	9
2.1 Personnel Safety .....	9
2.2 Electrical connection safety .....	10
2.3 Installation Requirements .....	12
2.4 PE Connection and Leakage Current .....	15
2.5 Response to Emergency Situations .....	1
3 Product Introduction .....	1
3.1 Basic Features .....	1
3.2 Dimensions .....	5
3.3 Terminals of inverter .....	5
3.4 Battery System Features .....	6
3.5 Fire Protection Function .....	6
3.6 Warm up Function .....	8
4 Inverter and Battery Technical Data .....	10
4.1 PV Input .....	10
4.2 Battery .....	11
4.3 AC Output/Input .....	12
4.4 BACKUP Output .....	14
4.5 Efficiency and Standard .....	16
4.6 General Data .....	17
4.7 EQ3300-S/EQ3300-S (w) Specifications .....	18

4.8 EQ4800-S/TQ4800-S Specifications .....	21
4.9 EQ5000-S/EQ5000-S (w)/TQ5000/TQ5000 (w)/ .....	23
EQ5000-S-P (w) Specifications .....	23
4.10 EQ5500-S/TQ5500-S Specifications .....	28
4.11 Overall Dimensions and Weight for the Stackable AIO System .....	30
5 Inverter and Battery Installation .....	31
5.1 Installation Precautions .....	31
5.2 UnPackaging .....	31
5.3 Installation Requirements .....	34
5.4 Tools Preparation .....	37
5.5 Inverter Handling .....	38
5.6 Installation Steps .....	39
6 Electrical Connection .....	43
6.1 Connection Overview .....	43
6.2 PV Connection .....	44
6.3 Grid Connection .....	47
6.4 Earth Connection .....	50
6.5 AC Cable Installation .....	51
6.6 RJ45 Connection .....	54
6.7 COM Connection .....	56
6.8 Electrical Connection .....	59
6.9 Backup Connection (Non-parallel State) .....	71
6.10 System Connection Diagrams .....	72
6.11 Inverter Start-Up .....	74
6.12 Inverter Switch Off .....	74
7 Main Function Implementation .....	75
7.1 DRM wiring .....	75

7.2 RCR wiring .....	76
7.3 SG ready wiring and setting .....	78
7.4 Reactive Function Setting .....	80
7.5 Implementation of dual-channel Backup function .....	84
7.6 Parallel connection wiring and operating instructions .....	85
8 Firmware Upgrading .....	92
9 Operation .....	97
9.1 Control Panel .....	97
9.2 Function Tree .....	99
10 Maintenance .....	100
10.1 Alarm List .....	100
10.2 Troubleshooting and Routine Maintenance .....	105
11 Inverter Storage and Disposal .....	106
11.1 Disassembling the Inverter .....	106
11.2 Storing the Inverter .....	106
11.3 Transporting the Inverter .....	106
11.4 Decommissioning/Scrapping the Inverter .....	106
12 Battery Troubleshooting and Maintenance .....	107
12.1 Maintenance .....	107
12.2 Storage with Low SOC .....	107
12.3 Troubleshooting .....	108
13 Appendix .....	109
13.1 Quality Guarantee .....	109
13.2 Contact Us .....	110

# 1 Notes on This Manual

Stackable AIO series inverters are designed and tested in accordance with international safety requirements. Certain safety precautions must be taken when installing and operating this inverter. The installer must read and follow all instructions, cautions and warnings in this installation manual.

## 1.1 Scope of Validity

This manual describes the assembly, installation, commissioning, maintenance and troubleshooting of the following model(s) of products:

HQ3-5.0\_EQ3300-S/HQ3-5.0\_EQ3300-S (w), HQ3-5.0\_EQ4800-S,  
HQ3-5.0\_EQ5000-S/HQ3-5.0\_EQ5000-S (w), HQ3-5.0\_EQ5500-S

HQ3-6.0\_EQ3300-S/HQ3-6.0\_EQ3300-S (w), HQ3-6.0\_EQ4800-S,  
HQ3-6.0\_EQ5000-S/HQ3-6.0\_EQ5000-S (w), HQ3-6.0\_EQ5500-S

HQ3-8.0\_EQ3300-S/HQ3-8.0\_EQ3300-S (w), HQ3-8.0\_EQ4800-S,  
HQ3-8.0\_EQ5000-S/HQ3-8.0\_EQ5000-S (w), HQ3-8.0\_EQ5500-S

HQ3-10.0\_EQ3300-S/HQ3-10.0\_EQ3300-S (w), HQ3-10.0\_EQ4800-S,  
HQ3-10.0\_EQ5000-S/HQ3-10.0\_EQ5000-S (w), HQ3-10.0\_EQ5500-S

HQ3-12.0\_EQ3300-S/HQ3-12.0\_EQ3300-S (w), HQ3-12.0\_EQ4800-S,  
HQ3-12.0\_EQ5000-S/HQ3-12.0\_EQ5000-S (w), HQ3-12.0\_EQ5500-S

HQ3-15.0\_EQ3300-S/HQ3-15.0\_EQ3300-S (w), HQ3-15.0\_EQ4800-S,  
HQ3-15.0\_EQ5000-S/HQ3-15.0\_EQ5000-S (w), HQ3-15.0\_EQ5500-S

HQ3-5.0-AC\_EQ3300-S/HQ3-5.0-AC\_EQ3300-S (w), HQ3-5.0-AC\_EQ4800-S,  
HQ3-5.0-AC\_EQ5000-S/HQ3-5.0-AC\_EQ5000-S (w), HQ3-5.0-AC\_EQ5500-S

HQ3-6.0-AC\_EQ3300-S/HQ3-6.0-AC\_EQ3300-S (w), HQ3-6.0-AC\_EQ4800-S,  
HQ3-6.0-AC\_EQ5000-S/HQ3-6.0-AC\_EQ5000-S (w), HQ3-6.0-AC\_EQ5500-S

HQ3-8.0-AC\_EQ3300-S/HQ3-8.0-AC\_EQ3300-S (w), HQ3-8.0-AC\_EQ4800-S,  
HQ3-8.0-AC\_EQ5000-S/HQ3-8.0-AC\_EQ5000-S (w), HQ3-8.0-AC\_EQ5500-S

HQ3-10.0-AC\_EQ3300-S/HQ3-10.0-AC\_EQ3300-S (w), HQ3-10.0-AC\_EQ4800-S,  
HQ3-10.0-AC\_EQ5000-S/HQ3-10.0-AC\_EQ5000-S (w), HQ3-10.0-AC\_EQ5500-S

HQ3-12.0-AC\_EQ3300-S/HQ3-12.0-AC\_EQ3300-S (w), HQ3-12.0-AC\_EQ4800-S,  
HQ3-12.0-AC\_EQ5000-S/HQ3-12.0-AC\_EQ5000-S (w), HQ3-12.0-AC\_EQ5500-S

HQ3-15.0-AC\_EQ3300-S/HQ3-15.0-AC\_EQ3300-S (w), HQ3-15.0-AC\_EQ4800-S,  
HQ3-15.0-AC\_EQ5000-S/HQ3-15.0-AC\_EQ5000-S (w), HQ3-15.0-AC\_EQ5500-S

HQ3-5.0-M\_EQ3300-S/HQ3-5.0-M\_EQ3300-S (w), HQ3-5.0-M\_EQ4800-S,  
 HQ3-5.0-M\_EQ5000-S/HQ3-5.0-M\_EQ5000-S (w), HQ3-5.0-M\_EQ5500-S/  
 HQ3-5.0-M\_EQ5000-S-P (w)

HQ3-6.0-M\_EQ3300-S/HQ3-6.0-M\_EQ3300-S (w), HQ3-6.0-M\_EQ4800-S,  
 HQ3-6.0-M\_EQ5000-S/HQ3-6.0-M\_EQ5000-S (w),  
 HQ3-6.0-M\_EQ5500-S/HQ3-6.0-M\_EQ5000-S-P (w)

HQ3-8.0-M\_EQ3300-S/HQ3-8.0-M\_EQ3300-S (w), HQ3-8.0-M\_EQ4800-S,  
 HQ3-8.0-M\_EQ5000-S/HQ3-8.0-M\_EQ5000-S (w),  
 HQ3-8.0-M\_EQ5500-S/HQ3-8.0-M\_EQ5000-S-P (w)

HQ3-10.0-M\_EQ3300-S/HQ3-10.0-M\_EQ3300-S (w), HQ3-10.0-M\_EQ4800-S,  
 HQ3-10.0-M\_EQ5000-S/HQ3-10.0-M\_EQ5000-S (w),  
 HQ3-10.0-M\_EQ5500-S/HQ3-8.0-M\_EQ5500-S/HQ3-10.0-M\_EQ5000-S-P (w)

HQ3-12.0-M\_EQ3300-S/HQ3-12.0-M\_EQ3300-S (w), HQ3-12.0-M\_EQ4800-S,  
 HQ3-12.0-M\_EQ5000-S/HQ3-12.0-M\_EQ5000-S (w),  
 HQ3-12.0-M\_EQ5500-S/HQ3-8.0-M\_EQ5500-S/HQ3-12.0-M\_EQ5000-S-P (w)

HQ3-15.0-M\_EQ3300-S/HQ3-15.0-M\_EQ3300-S (w), HQ3-15.0-M\_EQ4800-S,  
 HQ3-15.0-M\_EQ5000-S/HQ3-15.0-M\_EQ5000-S (w),  
 HQ3-15.0-M\_EQ5500-S/HQ3-8.0-M\_EQ5500-S/HQ3-15.0-M\_EQ5000-S-P (w)

HQ3-5.0-M-AC\_EQ3300-S/HQ3-5.0-M-AC\_EQ3300-S (w), HQ3-5.0-M-AC\_EQ4800-S,  
 HQ3-5.0-M-AC\_EQ5000-S/HQ3-5.0-M-AC\_EQ5000-S (w),  
 HQ3-5.0-M-AC\_EQ5500-S/HQ3-5.0-M-AC\_EQ5000-S (w)

HQ3-6.0-M-AC\_EQ3300-S/HQ3-6.0-M-AC\_EQ3300-S (w), HQ3-6.0-M-AC\_EQ4800-S,  
 HQ3-6.0-M-AC\_EQ5000-S/HQ3-6.0-M-AC\_EQ5000-S (w),  
 HQ3-6.0-M-AC\_EQ5500-S/HQ3-6.0-M-AC\_EQ5000-S (w)

HQ3-8.0-M-AC\_EQ3300-S/HQ3-8.0-M-AC\_EQ3300-S (w), HQ3-8.0-M-AC\_EQ4800-S,  
 HQ3-8.0-M-AC\_EQ5000-S/HQ3-8.0-M-AC\_EQ5000-S (w),  
 HQ3-8.0-M-AC\_EQ5500-S/HQ3-8.0-M-AC\_EQ5000-S (w)

HQ3-10.0-M-AC\_EQ3300-S/HQ3-10.0-M-AC\_EQ3300-S (w), HQ3-10.0-M-AC\_EQ4800-S  
 HQ3-10.0-M-AC\_EQ5000-S/HQ3-10.0-M-AC\_EQ5000-S (w),  
 HQ3-10.0-M-AC\_EQ5500-S/HQ3-10.0-M-AC\_EQ5000-S (w)

HQ3-12.0-M-AC\_EQ3300-S/HQ3-12.0-M-AC\_EQ3300-S (w), HQ3-12.0-M-AC\_EQ4800-S  
 HQ3-12.0-M-AC\_EQ5000-S/HQ3-12.0-M-AC\_EQ5000-S (w),  
 HQ3-12.0-M-AC\_EQ5500-S/HQ3-12.0-M-AC\_EQ5000-S (w)

HQ3-15.0-M-AC\_EQ3300-S/HQ3-15.0-M-AC\_EQ3300-S (w), HQ3-15.0-M-AC\_EQ4800-S  
 HQ3-15.0-M-AC\_EQ5000-S/HQ3-15.0-M-AC\_EQ5000-S (w),  
 HQ3-15.0-M-AC\_EQ5500-S/HQ3-15.0-M-AC\_EQ5000-S (w)

PQ3-5.0\_EQ4800-S, PQ3-5.0\_TQ4800-S, PQ3-5.0\_EQ5000-S/PQ3-5.0\_EQ5000-S (w),  
 PQ3-5.0\_TQ5000-S/PQ3-5.0\_TQ5000-S (w), PQ3-5.0\_EQ5500-S, PQ3-5.0\_TQ5500-S  
 PQ3-6.0\_EQ4800-S, PQ3-6.0\_TQ4800-S, PQ3-6.0\_EQ5000-S/PQ3-6.0\_EQ5000-S (w),

PQ3-6.0\_TQ5000-S/PQ3-6.0\_TQ5000-S (w), PQ3-6.0\_EQ5500-S, PQ3-6.0\_TQ5500-S  
PQ3-8.0\_EQ4800-S, PQ3-8.0\_TQ4800-S, PQ3-8.0\_EQ5000-S/PQ3-8.0\_EQ5000-S (w),  
PQ3-8.0\_TQ5000-S/PQ3-8.0\_TQ5000-S (w), PQ3-8.0\_EQ5500-S, PQ3-8.0\_TQ5500-S  
PQ3-10.0\_EQ4800-S, PQ3-10.0\_TQ4800-S, PQ3-10.0\_EQ5000-S/  
PQ3-10.0\_EQ5000-S (w),  
PQ3-10.0\_TQ5000-S/PQ3-10.0\_TQ5000-S (w), PQ3-10.0\_EQ5500-S, PQ3-10.0\_TQ5500-S  
PQ3-10.0-L\_EQ4800-S, PQ3-10.0-L\_TQ4800-S, PQ3-10.0-L\_EQ5000-S/  
PQ3-10.0\_EQ5000-S (w),  
PQ3-10.0-L\_TQ5000-S/PQ3-10.0-L\_TQ5000-S (w), PQ3-10.0-L\_EQ5500-S,  
PQ3-10.0-L\_TQ5500-S  
PQ3-12.0\_EQ4800-S, PQ3-12.0\_TQ4800-S, PQ3-12.0\_EQ5000-S/  
PQ3-12.0\_EQ5000-S (w),  
PQ3-12.0\_TQ5000-S/PQ3-12.0\_TQ5000-S (w), PQ3-12.0\_EQ5500-S, PQ3-12.0\_TQ5500-S  
PQ3-15.0\_EQ4800-S, PQ3-15.0\_TQ4800-S, PQ3-15.0\_EQ5000-S/  
PQ3-15.0\_EQ5000-S (w),  
PQ3-15.0\_TQ5000-S/PQ3-15.0\_TQ5000-S (w), PQ3-15.0\_EQ5500-S, PQ3-15.0\_TQ5500-S

PQ3-5.0-AC\_EQ4800-S, PQ3-5.0-AC\_TQ4800-S, PQ3-5.0-AC\_EQ5000-S/  
PQ3-5.0-AC\_EQ5000-S (w), PQ3-5.0-AC\_TQ5000-S/PQ3-5.0-AC\_TQ5000-S (w),  
PQ3-5.0-AC\_EQ5500-S, PQ3-5.0-AC\_TQ5500-S

PQ3-6.0-AC\_EQ4800-S, PQ3-6.0-AC\_TQ4800-S, PQ3-6.0-AC\_EQ5000-S/  
PQ3-6.0-AC\_EQ5000-S (w), PQ3-6.0-AC\_TQ5000-S/PQ3-6.0-AC\_TQ5000-S (w),  
PQ3-6.0-AC\_EQ5500-S, PQ3-6.0-AC\_TQ5500-S

PQ3-8.0-AC\_EQ4800-S, PQ3-8.0-AC\_TQ4800-S, PQ3-8.0-AC\_EQ5000-S/  
PQ3-8.0-AC\_EQ5000-S (w), PQ3-8.0-AC\_TQ5000-S/PQ3-8.0-AC\_TQ5000-S (w),  
PQ3-8.0-AC\_EQ5500-S, PQ3-8.0-AC\_TQ5500-S

PQ3-10.0-AC\_EQ4800-S, PQ3-10.0-AC\_TQ4800-S, PQ3-10.0-AC\_EQ5000-S/  
PQ3-10.0-AC\_EQ5000-S (w), PQ3-10.0-AC\_TQ5000-S/PQ3-10.0-AC\_TQ5000-S (w),  
PQ3-10.0-AC\_EQ5500-S, PQ3-10.0-AC\_TQ5500-S

PQ3-10.0-L-AC\_EQ4800-S, PQ3-10.0-L-AC\_TQ4800-S, PQ3-10.0-L-AC\_EQ5000-S/  
PQ3-10.0-L-AC\_EQ5000-S (w), PQ3-10.0-L-AC\_TQ5000-S/  
PQ3-10.0-L-AC\_TQ5000-S (w), PQ3-10.0-L-AC\_EQ5500-S, PQ3-10.0-L-AC\_TQ5500-S

PQ3-12.0-AC\_EQ4800-S, PQ3-12.0-AC\_TQ4800-S, PQ3-12.0-AC\_EQ5000-S/  
PQ3-12.0-AC\_EQ5000-S (w), PQ3-12.0-AC\_TQ5000-S/PQ3-12.0-AC\_TQ5000-S (w),  
PQ3-12.0-AC\_EQ5500-S, PQ3-12.0-AC\_TQ5500-S

PQ3-15.0-AC\_EQ4800-S, PQ3-15.0-AC\_TQ4800-S, PQ3-15.0-AC\_EQ5000-S/  
PQ3-15.0-AC\_EQ5000-S (w), PQ3-15.0-AC\_TQ5000-S/PQ3-15.0-AC\_TQ5000-S (w),  
PQ3-15.0-AC\_EQ5500-S, PQ3-15.0-AC\_TQ5500-S

PQ3-5.0-M\_EQ4800-S, PQ3-5.0-M\_TQ4800-S, PQ3-5.0-M\_EQ5500-S,  
PQ3-5.0-M\_TQ5500-S, PQ3-5.0-M\_EQ5000-S/PQ3-5.0-M\_EQ5000-S (w),  
PQ3-5.0-M\_TQ5000-S/PQ3-5.0-M\_TQ5000-S (w)

PQ3-6.0-M\_EQ4800-S, PQ3-6.0-M\_TQ4800-S, PQ3-6.0-M\_EQ5500-S,  
PQ3-6.0-M\_TQ5500-S, PQ3-6.0-M\_EQ5000-S/PQ3-6.0-M\_EQ5000-S (w),  
PQ3-6.0-M\_TQ5000-S/PQ3-6.0-M\_TQ5000-S (w)

PQ3-8.0-M\_EQ4800-S, PQ3-8.0-M\_TQ4800-S, PQ3-8.0-M\_EQ5500-S,  
PQ3-8.0-M\_TQ5500-S, PQ3-8.0-M\_EQ5000-S/PQ3-8.0-M\_EQ5000-S (w),  
PQ3-8.0-M\_TQ5000-S/PQ3-8.0-M\_TQ5000-S (w)

PQ3-10.0-M\_EQ4800-S, PQ3-10.0-M\_TQ4800-S, PQ3-10.0-M\_EQ5500-S,  
PQ3-10.0-M\_TQ5500-S, PQ3-10.0-M\_EQ5000-S/PQ3-10.0-M\_EQ5000-S (w),  
PQ3-10.0-M\_TQ5000-S/PQ3-10.0-M\_TQ5000-S (w)

PQ3-10.0-L-M\_EQ4800-S, PQ3-10.0-L-M\_TQ4800-S, PQ3-10.0-L-M\_EQ5500-S,  
PQ3-10.0-L-M\_TQ5500-S, PQ3-10.0-L-M\_EQ5000-S/PQ3-10.0-L-M\_EQ5000-S (w),  
PQ3-10.0-L-M\_TQ5000-S/PQ3-10.0-L-M\_TQ5000-S (w)

PQ3-12.0-M\_EQ4800-S, PQ3-12.0-M\_TQ4800-S, PQ3-12.0-M\_EQ5500-S,  
PQ3-12.0-M\_TQ5500-S, PQ3-12.0-M\_EQ5000-S/PQ3-12.0-M\_EQ5000-S (w),  
PQ3-12.0-M\_TQ5000-S/PQ3-12.0-M\_TQ5000-S (w)

PQ3-15.0-M\_EQ4800-S, PQ3-15.0-M\_TQ4800-S, PQ3-15.0-M\_EQ5500-S,  
PQ3-15.0-M\_TQ5500-S, PQ3-15.0-M\_EQ5000-S/PQ3-15.0-M\_EQ5000-S (w),  
PQ3-15.0-M\_TQ5000-S/PQ3-15.0-M\_TQ5000-S (w)

PQ3-5.0-M-AC\_EQ4800-S, PQ3-5.0-M-AC\_TQ4800-S, PQ3-5.0-M-AC\_EQ5500-S,  
PQ3-5.0-M-AC\_TQ5500-S, PQ3-5.0-M-AC\_EQ5000-S/PQ3-5.0-M-AC\_EQ5000-S (w),  
PQ3-5.0-M-AC\_TQ5000-S/PQ3-5.0-M-AC\_TQ5000-S (w)

PQ3-6.0-M-AC\_EQ4800-S, PQ3-6.0-M-AC\_TQ4800-S, PQ3-6.0-M-AC\_EQ5500-S,  
PQ3-6.0-M-AC\_TQ5500-S, PQ3-6.0-M-AC\_EQ5000-S/PQ3-6.0-M-AC\_EQ5000-S (w),  
PQ3-6.0-M-AC\_TQ5000-S/PQ3-6.0-M-AC\_TQ5000-S (w)

PQ3-8.0-M-AC\_EQ4800-S, PQ3-8.0-M-AC\_TQ4800-S, PQ3-8.0-M-AC\_EQ5500-S,  
PQ3-8.0-M-AC\_TQ5500-S, PQ3-8.0-M-AC\_EQ5000-S/PQ3-8.0-M-AC\_EQ5000-S (w),  
PQ3-8.0-M-AC\_TQ5000-S/PQ3-8.0-M-AC\_TQ5000-S (w)

PQ3-10.0-M-AC\_EQ4800-S, PQ3-10.0-M-AC\_TQ4800-S, PQ3-10.0-M-AC\_EQ5500-S,  
PQ3-10.0-M-AC\_TQ5500-S, PQ3-10.0-M-AC\_EQ5000-S/PQ3-10.0-M-AC\_EQ5000-S (w),  
PQ3-10.0-M-AC\_TQ5000-S/PQ3-10.0-M-AC\_TQ5000-S (w)

PQ3-10.0-L-M-AC\_EQ4800-S, PQ3-10.0-L-M-AC\_TQ4800-S,  
PQ3-10.0-L-M-AC\_EQ5500-S, PQ3-10.0-L-M-AC\_TQ5500-S,  
PQ3-10.0-L-M-AC\_EQ5000-S/PQ3-10.0-L-M-AC\_EQ5000-S (w),  
PQ3-10.0-L-M-AC\_TQ5000-S/PQ3-10.0-L-M-AC\_TQ5000-S (w)

PQ3-12.0-M-AC\_EQ4800-S, PQ3-12.0-M-AC\_TQ4800-S, PQ3-12.0-M-AC\_EQ5500-S,  
PQ3-12.0-M-AC\_TQ5500-S, PQ3-12.0-M-AC\_EQ5000-S/PQ3-12.0-M-AC\_EQ5000-S (w),  
PQ3-12.0-M-AC\_TQ5000-S/PQ3-12.0-M-AC\_TQ5000-S (w)

PQ3-15.0-M-AC\_EQ4800-S, PQ3-15.0-M-AC\_TQ4800-S, PQ3-15.0-M-AC\_EQ5500-S,  
PQ3-15.0-M-AC\_TQ5500-S, PQ3-15.0-M-AC\_EQ5000-S/PQ3-15.0-M-AC\_EQ5000-S (w),  
PQ3-15.0-M-AC\_TQ5000-S/PQ3-15.0-M-AC\_TQ5000-S (w)

## 1.2 Target Group

This manual is intended for use by qualified electricians only. All procedures described herein shall be performed by trained and experienced electrical personnel in compliance with basic electrical safety requirements.

## 1.3 Symbols Used

The following symbols are used in the manual to highlight information in order to ensure the safety of the user's person and property when using the product, and to use the product more efficiently and optimally. The following symbols may appear in this manual, and the meanings they represent are listed below:

### **Danger!**

"Danger" indicates a hazardous situation which, if not avoided, will result in death or serious injury.

### **Warning!**

"Warning" indicates a hazardous situation which, if not avoided, could result in minor or moderate injury.

### **Note!**

"Note" provides important tips and guidance.

### **Danger!**

The PV string will generate lethal high voltage when exposed to sunlight.

Operators must wear proper personal protective equipment during electrical connections.

Must ensure that cables are voltage-free with a measuring instrument before touching DC cables.

Respect all safety instructions listed in relevant documents about PV strings.

### **Danger!**

Before electrical connections, please make sure that the inverter switch and all switches connected to the inverter are set to "OFF", otherwise electric shock may occur!

Ensure that the inverter is undamaged and all cables are voltage free before performing electrical work. Do not close the AC circuit breaker until the electrical connection is complete.

### **Warning!**

Damage to the product caused by incorrect wiring is not covered by the warranty.

Electrical connection must be performed by professionals.

Operators must wear proper personal protective equipment during electrical connections.

All cables used in the PV generation system must be firmly attached, properly insulated, and adequately dimensioned.

---

**⚠ Danger!**

The PV string will generate lethal high voltage when exposed to sunlight.

Respect all safety instructions listed in relevant documents about PV strings.

---

**⚠ Warning!**

Make sure the PV array is well insulated to ground before connecting it to the inverter.

Make sure the maximum DC voltage and the maximum short circuit current of any string never exceed inverter permitted values specified in "Technical Data" Check the positive and negative polarity of the PV strings, and connect the PV connectors to corresponding terminals only after ensuring polarity correctness.

During the installation and operation of the inverter, please ensure that the positive or negative electrodes of PV strings do not short-circuit to the ground. Otherwise, an AC or DC short-circuit may occur, resulting in equipment damage. The damage caused by this is not covered by the warranty.

Electric arc or contractor over-temperature may occur if the PV connectors are not firmly in place, and Stackable AIO shall not be held liable for any damage caused.











If the DC input cables are reversely connected and the DC switch has been rotated to "ON", do not operate immediately. Otherwise, the inverter may be damaged. Please turn the Dc switch to "OFF" and remove the DC connector to adjust the polarity of the strings when the string current is lower than 0.5 A.

---

**⚠ Warning!**

Before connecting the PV array to the inverter, ensure that the impedances between the positive terminals of the PV string and earth, and between the negative terminals of the PV string and earth are larger than 1 M Ohm.

---

Symbols	Explanation
	CE mark. The product complies with the relevant EU directives.
	RCM mark.
	RoHS mark.
	Beware of hot surface. The inverter can become hot during operation. Avoid contact during operation.
	Danger of high voltages. Danger to life due to high voltages in the inverter!
	Hazards, warnings and cautions. Important safety information regarding personal safety. Failure to follow the safety information in this manual could result in injury or even death.
	Capacitor discharge. Before opening the cover, the inverter must be disconnected from the grid and the PV string. Wait at least 15 minutes for the storage capacitors to discharge completely.
	Read the manual before performing any operations on the inverter.
	Product should not be disposed as household waste.
	PE conductor terminal.

# 2 Safety Precautions

## 2.1 Personnel Safety

### Danger!

#### Operating Requirements

- High voltage exists inside the equipment. Unauthorized removal of necessary protective measures, improper use, and improper installation and operation may cause serious safety hazards, shock hazards, or equipment damage, and the resulting damage to the equipment is not covered by the warranty.
- Do not energize the equipment without completing the installation or without professional confirmation, and strictly prohibit operation with electricity.

### Warning!

#### Operating Requirements

- Always use special insulated tools for wiring operations. Direct contact or contact with other conductors or indirect contact with the power supply equipment through wet objects is prohibited.
- During operation of the equipment, the enclosure temperature is high and there is a risk of burns. Before touching any part of the inverter, make sure that the equipment and its surfaces are at a contact-safe temperature and voltage before proceeding.

### Note!

#### Personnel requirements

- All operations, including transportation, installation, start-up and maintenance, must be performed by qualified and trained personnel.
- Before operating the equipment, be sure to check that it is in proper condition, including, but not limited to, the equipment's parts, safety devices, and meter display.
- If any abnormality is found during operation, do not use the inverter and avoid temporary maintenance of the inverter.
- Special scenario operators, such as electrical operation, high place operation, equipment maintenance operation, etc., must have special operation qualification that meets the requirements of the local country/region, and should comply with local standards and relevant safety codes.
- Strictly follow the safety operation procedures, understand the potential dangers in equipment operation, and take precautions to maximize the safety of themselves and related personnel to prevent accidents caused by improper operation.
- Operators are required to wear appropriate personal protective equipment, including protective clothing, gloves, goggles, and helmets.
- It is strictly prohibited to operate under fatigue, drunkenness, or ill health.
- Take extra care when the inverter is disconnected from the public grid, as certain components may hold a certain voltage, creating a risk of electric shock.
- Before installation, check the machine to make sure that it does not have any damage caused by transportation or handling processes that could affect the

insulation or safety distances. Choose the installation location carefully and observe the specified cooling requirements.

- Before connecting the inverter to the distribution grid, contact the local distribution grid company for approval. This connection must be carried out by a qualified technician.
- Do not use the equipment when the safety devices do not work or are disabled.
- The manufacturer needs to be notified of any non-standard installation conditions.
- All repairs should be carried out only with approved spare parts, which must be installed in accordance with their purpose and by an authorized contractor or an authorized service representative.

## 2.2 Electrical connection safety

### Danger!

#### Operating Requirements

- Remove all electrical connections from the unit before making electrical connections.
- Before making electrical connections, it is important to verify that the equipment itself and its front and rear switches are disconnected and that reliable locking and marking measures are in place to prevent accidental energization.

#### Wiring Requirements

- No loads may be connected between the inverter and its directly connected AC circuit breaker.
- Use test equipment to ensure that the PV strings have the correct positive and negative terminals.
- The entire grounding system should remain intact, including the grounding electrode, grounding trunk, branch wires, and connections to the equipment.

#### Grounding Requirements

- The protective earth conductor needs to remain grounded during installation and when removing the equipment.

#### Maintenance Requirements

- High voltage exists inside the unit, do not open the unit's mainframe panel.
- Disconnect the corresponding output switch of the power supply unit before performing maintenance on the power supply unit's back-end electricity or power distribution equipment.

### Warning!

#### Wiring Requirements

- In electrical installations, it is important to follow the relevant codes and standards and to use circuit breakers of appropriate specifications to protect the safety of the circuit.

#### Grounding Requirements

- The grounding resistance should be in accordance with relevant standards and regulations to ensure effective current discharge. Normally, the value of grounding

resistance should be small enough to ensure that the current can be quickly directed to earth in the event of a fault.

### Maintenance Requirements

- Always use measuring equipment to ensure that the equipment is at contact-safe temperatures and voltages before touching any parts, and wear protective equipment for operation and maintenance of the inverter.

### Note!

#### Wiring Requirements

- Wires should be secured and supported at appropriate locations to prevent dislodgement or damage due to self-weight or external forces.

#### Inspection before connection

- Check the appearance and structure of the equipment for damage, whether the equipment received and the actual equipment ordered are the same, and contact Fox ESS in case of doubt, connecting damaged equipment can cause the risk of fire and electric shock.

#### Wiring Requirements

- Cable slots and crossing holes should have no sharp edges and the location of the pipe or crossing holes should be protected to prevent damage to the cables.

- Strictly follow national and industry standards and codes for electrical wiring for construction and installation.
- Verify that tools and test equipment used are functioning properly, calibrated effectively, and meet safety standards, and check and register the number of tools to prevent them from being left inside the equipment.
- Check that markings and labels on wires, terminals and equipment are clear and accurate.
- Check that connecting terminals are well insulated and protected, free from corrosion, deformation or looseness.
- Incorrect wiring operations can cause accidents such as fire or electric shock, and the resulting damage will not be covered by the warranty.
- Wiring should be clearly labeled to facilitate maintenance and troubleshooting.
- Wiring personnel need to wear appropriate personal protective equipment and use professional insulated tools for operation .
- The grounding system should be tested regularly to check the grounding resistance, connection status, etc. Before operating the equipment, ensure that the equipment is reliably grounded, and find and repair any damage or abnormality in time.
- Cabling should be kept at a safe distance of at least 30mm from high temperature heat sources to prevent aging of the insulation.
- Cables should not block the air inlet and outlet of the equipment.
- After the connection is completed, it should be ensured that the insulation of the wires is restored intact and the exposed conductor parts are effectively insulated.
- The grounded portion should be clearly labeled to alert personnel.
- The grounding connection must be firm and reliable to avoid loose, corrosion, or poor contact. The connection shall be properly treated against corrosion.
- Wiring should be laid neatly and in an orderly manner, avoiding crossings, tangles

and excessive bending to minimize the risk of damage to the wires. Select power cords of sufficient length and strictly prohibit making joints or soldering points in power cords.

- The insulation of wires and cables should be intact and have good insulation properties to effectively prevent leakage and short circuit.
- The same kind of cables are tied neatly without outer skin damage, and different kinds of cables are laid out separately, forbidding twisting and crossing.
- Regularly check the system parameters and make records, if anomalies are found, the causes should be identified and dealt with accordingly. If you can not determine the cause of the anomaly, you need to turn to professionals to avoid accidents affecting the use of the system.
- Non-professionals are not allowed to disassemble and overhaul the inverter without authorization, and the operators need to be specially trained.
- Strictly follow the use and maintenance instructions of the product to operate, make sure the warning signs are intact, and replace the signs that become unclear due to long-term use in time.
- Regularly check whether the wiring and connecting terminals of each part of the equipment are firm and whether there is any looseness; especially pay attention to the fan, power module, input terminals, output terminals, grounding, and other parts.
- Place eye-catching warning signs or set up safety warning belts around the products; non-staff are not allowed to enter to avoid mishandling or accidents after unrelated personnel approach the products.
- Hang a "Danger - Do Not Close" tag on the upstream and downstream switches or circuit breakers, and post warning signs to prevent accidental connection.

## 2.3 Installation Requirements

### Danger!

#### Equipment Protection

- Strictly follow the operation manual and specifications of the equipment to carry out maintenance operations, do not carry out other maintenance operations beyond this manual without authorization to avoid equipment failure due to incorrect operation.
- Prohibit arc welding, drilling, cutting and other operations on the equipment, and prohibit the installation of other equipment on the top of the product.

#### Drilling Safety

- Avoid pre-buried pipes or lines when drilling to avoid short circuits or other hazards.
- The entire grounding system should be kept intact, including the grounding electrode, grounding trunk, branch lines, and connections to the equipment.
- In electrical installations, it is important to follow the relevant codes and standards and to use circuit breakers of the right size to protect the safety of the circuits.

### Note!

#### Use of Tools

- All tools must be complete, properly certified, and within their inspection validity period. Before use, ensure that the tools are sturdy and free from damage, loose parts, or missing components.

**Equipment Protection**

- Paint scratches, drops or rust stains that occur during transportation and installation of equipment must be repaired in a timely manner, and long-term exposure of the scratched part may affect the use of the inverter.

**Drilling Safety**

- Appropriate protective equipment such as goggles, earplugs, helmets, and coveralls should be worn when drilling to prevent splashing debris from hurting eyes and face, reduce noise damage to hearing, and protect the body from injury.
- Cabling should be kept at a safe distance of at least 30 mm from high temperature heat sources to prevent deterioration of the insulation.
- Cables should not block the air inlet or outlet of the equipment.

- Ensure that there is enough space and good lighting, and avoid using tools in dangerous or unstable environments.
- Use the tool correctly and operate the tool correctly according to the instruction manual or professional guidance on the correct way to use the tool.
- Perform regular maintenance, such as cleaning, lubrication, and calibration, to extend the service life of the tools and maintain their performance.
- Before operation, dust, dirt, and debris need to be removed from the surface of the equipment to prevent them from entering the interior of the equipment and causing damage.
- Update the operating system and related software of the equipment in time to fix the loopholes and improve the performance.
- Protect the equipment from external collision and strong vibration.
- Obtain consent from customers and contractors before drilling.
- Check the drilling equipment before use, including whether the drill is securely installed, whether the wires are broken, and whether the switch is normal.
- Ensure that the workpiece being drilled is securely fastened to prevent it from moving or rotating during drilling.
- When replacing drills, cleaning debris or performing equipment maintenance, strictly prevent debris from falling into the interior of the equipment, and be sure to stop the machine first and then clean up the debris in a timely manner.
- Do not connect the battery directly to inverter conductors or PV conductors. This will damage the battery and may result in explosion.
- After unpacking, please check the product for damages and missing parts.
- Make sure that the inverter and battery is completely turned off before commencing installation.
- Do not interchange the positive and negative terminals of the battery.
- Ensure that there is no short circuit of the terminals or with any external device.
- Do not exceed the battery voltage rating of the inverter.
- Do not connect the battery to any incompatible inverter.
- Do not connect different battery types together.
- Please ensure that all the batteries are grounded properly.
- Do not open the battery to repair or disassemble. Only Fox ESS is allowed to carry out any such repairs.
- In case of fire, use only dry powder fire extinguisher. Liquid extinguishers should not

be used.

- Please refrain from installing the battery near any water source to prevent accidental submersion.
- Recommend to install the battery away from children or pets.
- Do not use battery in high static environment where the protection device might be damaged.
- Do not install with other batteries or cells.
- Please ensure on installation site that the deviation of voltages between new batteries and every single present battery is less than 0.5V.
- Recommend to check the new batteries mounted on-site comply to the warranty scope or have ever been re-charged within 5 months; on top of that, please make sure the SOC of present battery system onsite is  $50\% \pm 5\%$ .
- Do not expose battery to open flame.
- Store in a cool and dry place with ample ventilation.
- Do not store the product near water sources.
- Store the product on a flat surface.
- Recommend to store the product out of reach of children and animals.
- Do not damage the unit by dropping, deforming, impacting, cutting or penetrating with a sharp object. It may cause leakage of electrolyte or fire.
- Do not touch any liquid spilled from the product. There is a risk of electric shock or damage to skin.
- Do not step on the product or place any foreign objects on it. This can result in damage.
- Do not charge or discharge damaged battery.

## 2.4 PE Connection and Leakage Current

### PV System Residual Current Factors

- In every PV installation, several elements contribute to the current leakage to protective earth (PE). These elements can be divided into two main types.
- Capacitive discharge current - Discharge current is generated mainly by the parasitic capacitance of the PV modules to PE. The module type, the environmental conditions (rain, humidity) and even the distance of the modules from the roof can affect the discharge current. Other factors that may contribute to the parasitic capacitance are the inverter's internal capacitance to PE and external protection elements such as lightning protection.
- During operation, the DC bus is connected to the alternating current grid via the inverter. Thus, a portion of the alternating voltage amplitude arrives at the DC bus. The fluctuating voltage constantly changes the charge state of the parasitic PV capacitor (i.e. capacitance to PE). This is associated with a displacement current, which is proportional to the capacitance and the applied voltage amplitude.
- Residual current - if there is a fault, such as defective insulation, where an energized cable comes into contact with a grounded person, an additional current flows, known as a residual current.

### Residual Current Device (RCMU)

- All inverters incorporate a certified internal RCMU (Residual current monitoring unit) to protect against possible electrocution in case of a malfunction of the PV array, cables or inverter (DC). The RCMU in the inverter can detect leakage on the DC side. There are 2 trip thresholds for the RCMU as required by the DIN VDE 0126-1-1 standard. A low threshold is used to protect against rapid changes in leakage typical of direct contact by people. A higher threshold is used for slowly rising leakage currents, to limit the current in grounding conductors for the safety. The default value for higher speed personal protection is 30mA, and 300mA per unit for lower speed fire safety.

### Installation and Selection of an External RCD device

- An external RCD is required in some countries. The installer must check which type of RCD is required by the specific local electric codes. Installation of an RCD must always be conducted in accordance with local codes and standards. It recommends the use of a type B RCD. This product can cause a DC current in the PE conductor. Where a residual current operated protective device (RCD) is used for protection against electric shock, only a RCD of type B is allowed on the supply side of this product. Unless a lower value is required by the specific local electric codes, suggest choosing a 300mA RCD.
- In installations where the local electric code requires an RCD with a lower leakage setting, the discharge current might result in nuisance tripping of the external RCD. The following steps are recommended to avoid nuisance tripping of the external RCD:
- Selecting the appropriate RCD is important for correct operation of the installation. An RCD with a rating of 30mA may trip at a leakage as low as 15mA (according to IEC 61008). High quality RCDs will typically trip at a value closer to their rating.

## 2.5 Response to Emergency Situations

The batteries comprise of multiple batteries connected in series. It is designed to prevent hazards or failures. However, Fox ESS cannot guarantee their absolute safety.

Under exposure to the internal materials of the battery the following recommendations should be carried out by the user.

- If there has been inhalation, please leave the contaminated area immediately and seek medical attention.
- If there has been contact with eyes, rinse the eyes with running water for 15 minutes and seek medical attention immediately.
- If there has been contact with the skin, wash the contacted area with soap thoroughly and seek medical attention immediately.
- If there has been ingestion, induce vomiting and seek medical attention.

### Fire Situation

In situations where the battery is on fire, if it is safe to do so, disconnect the battery pack by turn off the circuit breaker to shut off the power to the system. Use FM-200 or CO<sub>2</sub> fire extinguisher for the battery and an ABC fire extinguisher for the other parts of the system.

Under any fire situation, please evacuate the people from the building immediately before trying to extinguish it.

### Water Situation

The battery modules are not water resistant. Hence care should be taken not to get it wet. If you find the battery completely or partially submerged in water do not try to open. Contact an authorized personnel or Fox ESS for further instructions.

# 3 Product Introduction

## 3.1 Basic Features

Hybrid series are high-quality inverters which can convert solar energy to AC energy and store energy into battery. The inverter can be used to optimize self-consumption, store in the battery for future use or feed-in to public grid. Work mode depends on PV energy and user's preference.

Advantages	
	<ul style="list-style-type: none"> <li>✓ Advanced DSP control technology.</li> <li>✓ Utilizes the latest high-efficiency power component.</li> <li>✓ Advanced anti-islanding solutions.</li> <li>✓ IP66 protection level.</li> <li>✓ Max. Efficiency up to 98%; EU efficiency up to 97.3%; THD&lt;3%.</li> <li>✓ Safety &amp; Reliability: Transformerless design with software and hardware protection.</li> <li>✓ Export limitation (CT/Meter/DRM0/ESTOP).</li> <li>✓ Power factor regulation.</li> <li>✓ Friendly HMI.</li> <li>✓ LCD touch screen for inverter operation, displaying operational status and input/output power information.</li> <li>✓ PC remote control.</li> </ul>

### System connection diagrams

#### Note!

According to Australian safety requirements, the neutral cables of the on-grid side and backup side must be connected together. Otherwise, the backup function will not work.

This diagram is an example for an application that neutral connects with the PE in a distribution box.

For countries such as Australia, New Zealand, South Africa, etc, please follow local wiring regulations.

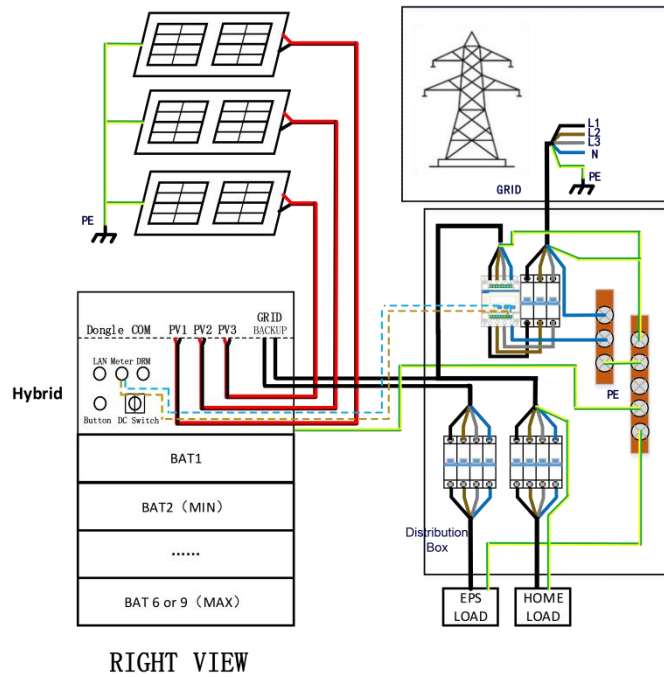

This diagram is an example for an application in which neutral is separated from the PE in the distribution box.

For countries such as China, Germany, the Czech Republic, Italy, etc, please follow local wiring regulations.

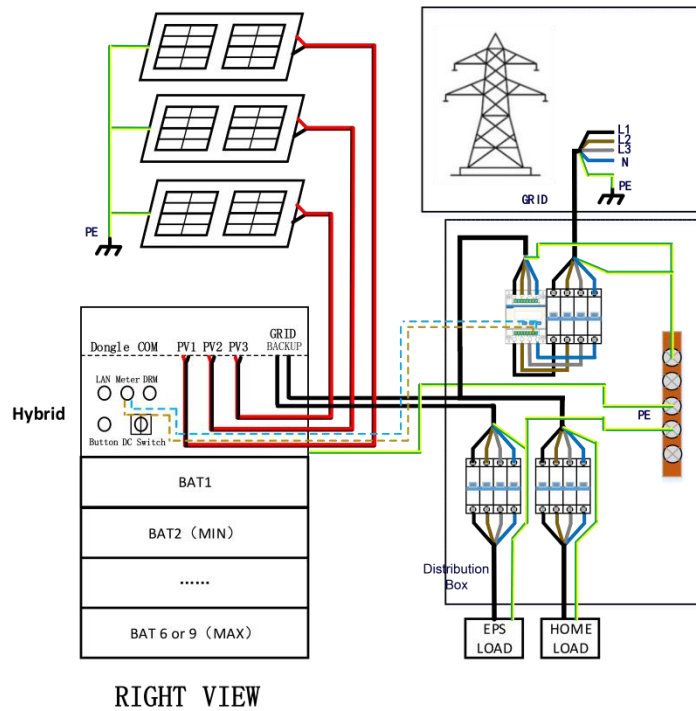

**Note!**

The number of batteries is determined by the battery model. The minimum number of batteries is 2.

Whole Home Backup

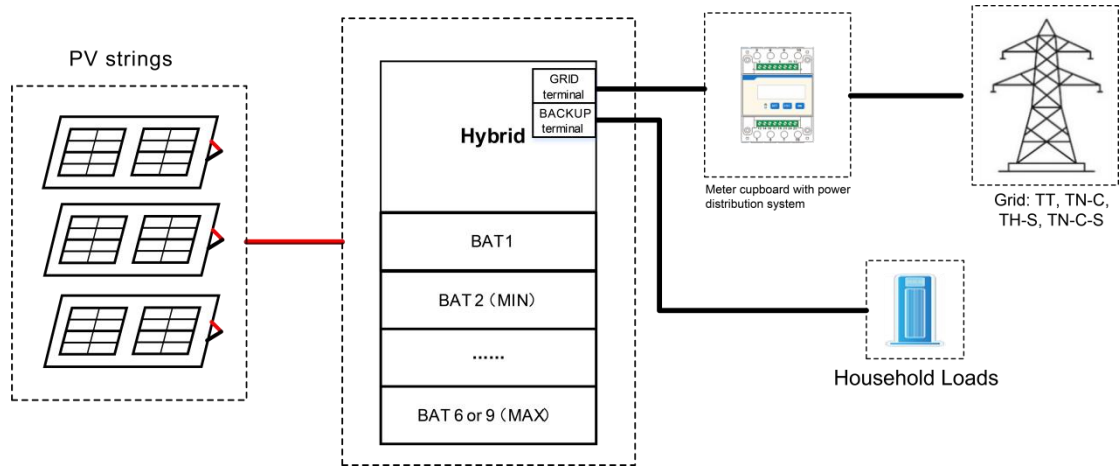

Work modes	Description
Self-use (with PV Power)	Priority: load>battery>grid The energy produced by the PV system is used to optimize self-consumption. The excess energy is used to charge the batteries, then exported to grid.
Self-use (without PV Power)	When no PV is supplied, the battery will discharge for local loads first. Battery will charge when excess generation from other generation sources is detected.
Feed in priority	Priority: load>grid>battery In the case of the external generator, the power generated will be used to supply the local loads firstly, then export to the public grid. The redundant power will charge the battery.
Back up mode	When the grid is off, system will supply emergency power from PV or battery to supply the home loads (Battery is necessary in Backup mode). Prioritize charging the battery, and ensure the battery does not discharge during grid-connected operation to maintain battery capacity for off-grid scenarios.
PeakShaving	The system can be set to provide a peak shaving function. A Peak Shaving limit must be set by adjusting "Import Limit" to the desired value. We can increase the peak shaving support uptime by setting the "Threshold SOC". When the battery is above the "Threshold SOC" the system will work in "Self-Use mode". When the battery is below the "Threshold SOC" the peak shaving function will be the priority and the system will only provide power from the battery when the "Import Limit" is exceeded. When below the "Threshold SOC" the system will charge from the grid when there is available power without exceeding the "Import Limit". This is to ensure prolonged Peak Shaving support for extended periods. If the "Import Limit" is exceeded constantly for an extended period of time, the peak shaving function can only guarantee successful operation while energy remains within the battery. If the battery designated "low level" is reached, the peak shaving function will cease.

★Charging time is when the battery is charged within the set time range. The setting of charging time can be used in the above work modes. The charging period is mainly used to set the charging time from the power grid to the battery. The PV can also charge the battery when there is sufficient PV outside of charging time.

Low-efficiency & Unbalanced-output: When the machine detects that the wiring of the electric meter and inverter is correct, it can output power based on the load size sampled by the electric meter. For example, the three circuits can output 1kW, 2kW, and 3kW respectively.

High-efficiency & Balanced-output only: Suitable for scenarios where balanced output is not a concern. The power output is evenly distributed across all three phases. For example, even if the loads are 1kW, 2kW, and 3kW, each phase will output 2kW uniformly.

Low-efficiency & Balanced-output only: The machine will default to this mode when it fails to detect correct wiring connections, preventing abnormal power output.

### 3.2 Dimensions

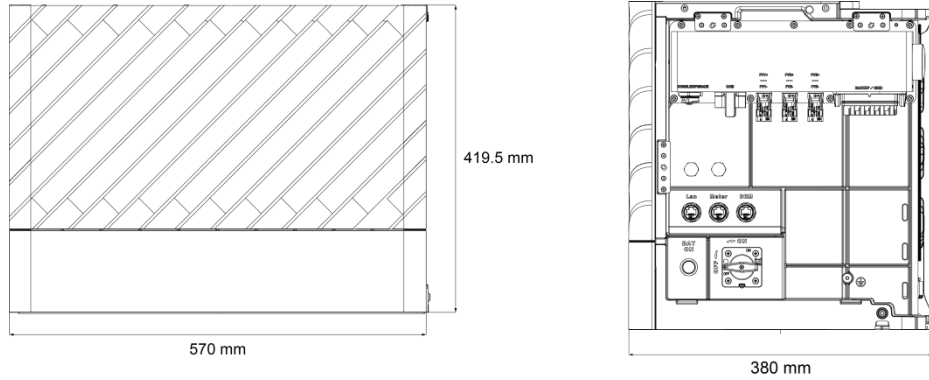

- This image is for reference only. The actual product received shall be final.

### 3.3 Terminals of inverter

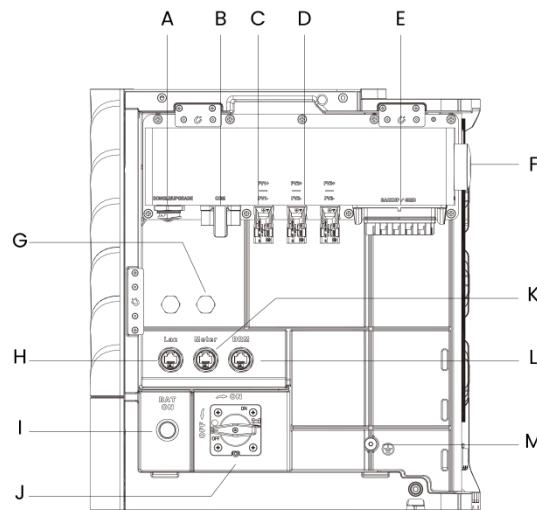

No.	Items	No.	Items
A	Dongle/Upgrade	H	Lan
B	COM	I	BAT ON off
C	PV+	J	DC switch
D	PV-	K	Meter
E	Grid/Backup	L	DRM
F	Antenna	M	Grounding screw
G	Waterproof lock valve		

Note: Only authorized personnel are permitted to set the connection.

### 3.4 Battery System Features

The batteries have been fitted with multiple protection systems to ensure the safe operation of the system. Some of the protection system includes:

- Inverter interface protection: Over voltage, Over current, External Short Circuit, Reverse Polarity, Ground Fault, Over Temp, In rush current.
- Battery Protection: Internal Short Circuit, Over voltage, over current, over temp, Under voltage.

The battery system contains the following Interface to allow it to connect and operate efficiently.

#### EQ-S Features:

Interface:

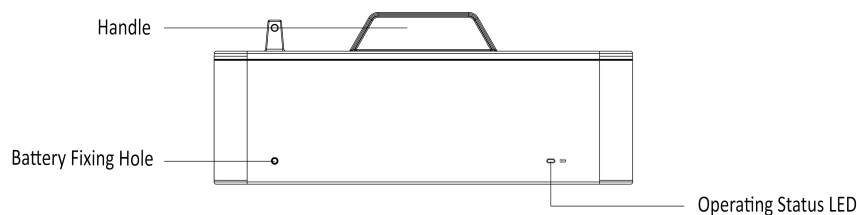

### 3.5 Fire Protection Function

Despite the extremely stable chemical properties of lithium iron phosphate batteries and the multiple protections, each battery unit is equipped with a fire protection module to further ensure the safety and reliability of Fox ESS batteries. This innovative module utilizes a new type of aerosol fire extinguishing device with features such as pressure-free storage, no maintenance required, high extinguishing efficiency, non-toxic and harmless characteristics.

#### 3.5.1 Fire Extinguishing Mechanism

The fire extinguishing mechanisms of common agents mainly include isolation, smothering, cooling, and chemical suppression, with different agents exhibiting varying mechanisms. The fire extinguishing mechanism of thermal aerosols involves two main mechanisms: the cooling effect from endothermic decomposition and the chemical suppression effects in both gas and solid phases, which work synergistically. Additionally, the gaseous components in the products of the aerosol extinguishing agent also play a supportive role.

#### Cooling Fire Extinguishing Effect from Endothermic Decomposition

The cooling effect of thermal aerosol extinguishing agents is primarily due to the endothermic decomposition of metal oxides and carbonates. When a fire occurs, the solid particles in the aerosol rapidly absorb heat from the fire source, resulting in a decrease in flame temperature. This reduction minimizes the heat radiating to the burning surface and lowers the energy required to dissociate vaporized combustible materials into free radicals.

As a result, the combustion reaction is effectively suppressed.

### Gas Phase Chemical Suppression Effect

Under thermal conditions, vaporized metal ions, such as strontium (Sr), potassium (K), and magnesium (Mg), exist as vapors and participate in multiple chain reactions with active combustion radicals including hydrogen (H·), hydroxyl (·OH), and oxygen (O·). For example:

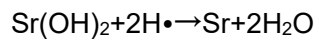
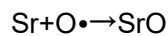
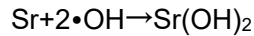

Through continuous action, this process consumes active combustion groups, significantly reducing their concentration and effectively suppressing combustion.

### Solid Phase Chemical Suppression Effect

The solid particles in thermal aerosol extinguishing agents can adsorb intermediates such as ·OH, H·, and O· from chain reactions, catalyzing their recombination into stable molecules. This interrupts the essential branching chain reactions in the combustion process. For example:

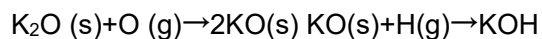

## 3.5.2 Technical Specifications

Activation method: Thermal activation

Thermal activation temperature:  $\geq 170^\circ\text{C}$

Discharge time:  $\leq 5$  seconds

Notes:

Please contact Fox ESS for immediate replacement if the fire protection module is activated.

Non-professionals should not disassemble the battery without authorization.

Do not touch the device until the casing has cooled after the internal fire extinguisher has been activated to prevent burns.

For further assistance, please contact an authorized personnel or Fox ESS for further instructions.

## 3.6 Warm up Function

In low-temperature climates at high altitudes or latitudes, particularly during winter, the charging and discharging performance of batteries can significantly decline due to cold temperatures. To address this Fox ESS has introduced a "Battery Warm up" feature, enabling the battery system to operate effectively extremely low temperatures. This feature is exclusively available in the warm-up versions.

When the battery temperature is between  $-25^{\circ}\text{C}$  and  $1^{\circ}\text{C}^{*1}$ , the system will warm up the battery to  $10^{\circ}\text{C}^{*1}$ . Warming up will stop once this temperature is reached, but if the battery temperature falls below  $1^{\circ}\text{C}^{*1}$  again, the warm up system will reactivate.

\*1: The user can set the start warm-up temperature and end warming up temperature through the inverter LCD or web page.

### 3.6.1 During Full Warm up Period

The warm up system prioritizes energy from the photovoltaic (PV) system. If PV power is insufficient, it will draw energy from either the battery or the grid, depending on the state of charge (SOC) of the battery:

- If the battery SOC  $\geq 40\%$ , energy will be drawn from the battery, following the priority order: PV > Battery > Grid.
- If the battery SOC  $< 40\%$ , energy will be sourced from the grid, with the following priority order: PV > Grid > Battery.

The full warming up function is turned off by default and must be enabled through the web interface or inverter settings when required.

### 3.6.2 During PV Warm up Period

The battery will only be warm up when surplus energy is available from the PV system.

The user can change the PV warm-up time range through the inverter LCD or web page

#### Important Notes:

1. The battery can only discharge when the internal temperature of battery is above  $-10^{\circ}\text{C}$ . It can only charge when the internal temperature of battery is above  $0^{\circ}\text{C}$ .
2. Please check that the wiring is properly connected and that all batteries are the warm up versions; otherwise, the Warming up function will not operate.
3. Warming up control is based on the internal cell temperature of the battery, rather than

the ambient temperature. Typically, the cell temperature will be higher than the ambient temperature under normal operating conditions.

For further assistance, please contact an authorized personnel or Fox ESS for further instructions.

**Note: Products with "(w)" suffix, such as EQ5000-S (w), among others, are equipped with Battery Warm up function. Without the "(w)" suffix, like EQ5000-S, among others, are not equipped with the Battery Warm up function.**

# 4 Inverter and Battery Technical Data

## 4.1 PV Input

Models	HQ3-5.0	HQ3-6.0	HQ3-8.0	HQ3-10.0	PQ3-10.0-L PQ3-10.0 -L-M	HQ3-12.0	HQ3-15.0
	HQ3-5.0-M	HQ3-6.0-M	HQ3-8.0-M	HQ3-10.0-M		HQ3-12.0-M	HQ3-15.0-M
	PQ3-5.0	PQ3-6.0	PQ3-8.0	PQ3-10.0		PQ3-12.0	PQ3-15.0
	PQ3-5.0-M	PQ3-6.0-M	PQ3-8.0-M	PQ3-10.0-M		PQ3-12.0-M	PQ3-15.0-M
Max. PV array power [W]	11000	14000	18000	20000	20000	24000	30000
Max. DC input power [W]	11000	13200	17600	20000	20000	24000	30000
Max. DC voltage [V d.c.]	1000 <sup>[1]</sup>						
Min. operating PV voltage [V d.c.]	90 <sup>[2]</sup>						
Nominal DC operating voltage [V d.c.]	620						
Max. MPPT input current [A d.c.]	20/20/20	20/20/20	20/20/20	20/20/20	20/20/20	20/20/20	20/20/20
Max. MPPT short circuit current [A d.c.]	25/25/25	25/25/25	25/25/25	25/25/25	25/25/25	25/25/25	25/25/25
MPPT voltage range [V d.c.]	120~950						
MPPT voltage range (full load) [V d.c.]	120~850	120~850	140~850	175~850	175~850	210~850	263~850
Start-up voltage [V d.c.]	140	140	140	140	140	140	140
No. of MPP trackers	3	3	3	3	3	3	3
Strings per MPP tracker	1+1+1	1+1+1	1+1+1	1+1+1	1+1+1	1+1+1	1+1+1

[1] For 1000V system, PV maximum operating voltage is 950V.

[2] The starting working voltage of the power supply is 90V.

## 4.2 Battery

Models	HQ3-5.0 HQ3-5.0-AC HQ3-5.0-M	HQ3-6.0 HQ3-6.0-AC HQ3-6.0-M	HQ3-8.0 HQ3-8.0-AC HQ3-8.0-M	HQ3-10.0 HQ3-10.0-AC HQ3-10.0-M	PQ3-10.0-L PQ3-10.0 -L-AC PQ3-10.0 -L-M PQ3-10.0-L -M-AC	HQ3-12.0 HQ3-12.0-AC HQ3-12.0-M HQ3-12.0 -M-AC PQ3-12.0 PQ3-12.0-AC PQ3-10.0-L-M PQ3-10.0-L -M-AC	HQ3-15.0 HQ3-15.0-AC HQ3-15.0-M HQ3-15.0 -M-AC PQ3-15.0 PQ3-15.0-AC PQ3-15.0-M PQ3-15.0 -M-AC
Battery Type	Lithium-ion battery (LFP)						
Battery voltage [V d.c.]	80~500						
Min. operating battery voltage [V d.c.]	85						
Full AC load battery voltage [V d.c.]	108	125	160	210	210	250	310
Max. Battery Charge Power [W]	6000	7200	9600	12000	12000	14400	15000
Max. Battery Discharge Power [W]	5000	6000	8000	10000	10000	12000	15000
Max. charge/ discharge current [A d.c.]	50.0						
Communication interface	CAN						

### 4.3 AC Output/Input

Models	HQ3-5.0	HQ3-6.0	HQ3-8.0	HQ3-10.0	PQ3-10.0-L PQ3-10.0 -L-AC	HQ3-12.0	HQ3-15.0
	HQ3-5.0	HQ3-6.0	HQ3-8.0	HQ3-10.0		HQ3-12.0	HQ3-15.0
	-AC	-AC	-AC	-AC		-AC	-AC
	PQ3-5.0	PQ3-6.0	PQ3-8.0	PQ3-10.0		PQ3-12.0	PQ3-15.0
	PQ3-5.0	PQ3-6.0	PQ3-8.0	PQ3-10.0		PQ3-12.0	PQ3-15.0
	-AC	-AC	-AC	-AC	-AC	-AC	
<b>AC output</b>							
Nominal AC power [W]	5000	6000	8000	10000	9999	12000	15000
Max. apparent AC power [VA]	5500	6600	8800	11000	9999	13200	16500
Rated grid voltage (AC voltage range) [V a.c.]	400V/230Vac; 380V/220Vac, 3L/N/PE						
Rated grid frequency [Hz]	50/60Hz,±5Hz						
Rated AC current (Per phase) [A a.c.]	7.2/7.6	8.7/9.1	11.6/12.1	14.5/15.2	14.5/15.2	17.4/18.2	21.7/22.7
Max. AC current (Per phase) [A a.c.]	8.0/8.3	9.6/10.0	12.8/13.3	15.9/16.7	14.5/15.2	19.1/20.0	23.9/25.0
Power factor	1 (Adjustable from 0.8 leading to 0.8 lagging)						
Export control	YES						
AC inrush current [A a.c.]	15A@0.5ms						
Max. output fault current [A a.c.]	150A@0.5ms						
Max. output over current protection [A a.c.]	50						
THDI	<3%@rated power						
<b>AC input</b>							
Max. AC power [VA]	17250	17250	17250	17250	17250	17250	17250
Rated grid voltage (AC voltage range) [V a.c.]	400V/230Vac; 380V/220Vac, 3L/N/PE						
Rated grid frequency [Hz]	50/60Hz, ±5Hz						
Max. AC current (Per phase) [A a.c.]	25	25	25	25	25	25	25
AC inrush current [A a.c.]	15A@0.5ms						

Models	HQ3-5.0-M	HQ3-6.0-M	HQ3-8.0-M	HQ3-10.0-M	PQ3-10.0-L -M PQ3-10.0-L -M-AC	HQ3-12.0-M	HQ3-15.0-M
	HQ3-5.0	HQ3-6.0	HQ3-8.0	HQ3-10.0		HQ3-12.0	HQ3-15.0
	-M-AC	-M-AC	-M-AC	-M-AC		-M-AC	-M-AC
	PQ3-5.0-M	PQ3-6.0-M	PQ3-8.0-M	PQ3-10.0-M		PQ3-12.0-M	PQ3-15.0-M
	PQ3-5.0	PQ3-6.0	PQ3-8.0	PQ3-10.0		PQ3-12.0	PQ3-15.0
-M-AC	-M-AC	-M-AC	-M-AC	-M-AC	-M-AC	-M-AC	
<b>AC output</b>							
Nominal AC power [VA]	5000	6000	8000	10000	9999	12000	15000
Max. apparent AC power [VA]	5500	6600	8800	11000	9999	13200	16500
Rated grid voltage (AC voltage range) [V a.c.]	400V/230Vac; 380V/220Vac, 3L/N/PE						
Rated grid frequency [Hz]	50/60Hz, ±5Hz						
Rated AC current (Per phase) [A a.c.]	7.2/7.6	8.7/9.1	11.6/12.1	14.5/15.2	14.5/15.2	17.4/18.2	21.7/22.7
Max. AC current (Per phase) [A a.c.]	8.0/8.3	9.6/10.0	12.8/13.3	15.9/16.7	14.5/15.2	19.1/20.0	23.9/25.0
Power factor	1 (Adjustable from 0.8 leading to 0.8 lagging)						
Export control	YES						
AC inrush current [A a.c.]	15A@0.5ms						
Max. output fault current [A a.c.]	150A@0.5ms						
Max. output over current protection [A a.c.]	50						
THDI	<3%@rated power						
<b>AC input</b>							
Max. AC power [VA]	43470	43470	43470	43470	43470	43470	43470
Rated grid voltage (AC voltage range) [V a.c.]	400V/230Vac; 380V/220Vac, 3L/N/PE						
Rated grid frequency [Hz]	50/60Hz, ±5Hz						
Max. AC current (Per phase) [A a.c.]	63	63	63	63	63	63	63
AC inrush current [A a.c.]	15A@0.5ms						

## 4.4 BACKUP Output

Models	HQ3-5.0	HQ3-6.0	HQ3-8.0	HQ3-10.0	PQ3-10.0-L PQ3-10.0 -L-AC	HQ3-12.0	HQ3-15.0
	HQ3-5.0	HQ3-6.0	HQ3-8.0	HQ3-10.0		HQ3-12.0	HQ3-15.0
	-AC	-AC	-AC	-AC		-AC	-AC
	PQ3-5.0	PQ3-6.0	PQ3-8.0	PQ3-10.0		PQ3-12.0	PQ3-15.0
	PQ3-5.0	PQ3-6.0	PQ3-8.0	PQ3-10.0		PQ3-12.0	PQ3-15.0
-AC	-AC	-AC	-AC	-AC	-AC	-AC	
<b>BACKUP Output (on grid mode)</b>							
Max. output power for backup load [3] [W]	17250	17250	17250	17250	17250	17250	17250
Max. output current for backup load [A a.c.]	25	25	25	25	25	25	25
<b>BACKUP Output (off grid mode)</b>							
Max. apparent AC power [VA]	5000	6000	8000	10000	10000	12000	15000
Peak apparent AC power [VA] (60s)	6000	7200	9600	12000	12000	14400	15000
Rated output voltage [V a.c.]	400V/230VAC; 3L/N/PE						
Rated grid frequency [Hz]	50/60	50/60	50/60	50/60	50/60	50/60	50/60
Backup max current (Per phase) [A a.c.]	7.2	8.7	11.6	14.5	14.5	17.4	21.7
Power factor	1 (Adjustable from 0.8 leading to 0.8 lagging)						
Parallel operation	Yes @max. 4 PCS						
Switch time	<10ms						
THDV	<3%@Linear Load						

Models	HQ3-5.0-M HQ3-5.0 -M-AC PQ3-5.0-M PQ3-5.0 -M-AC	HQ3-6.0-M HQ3-6.0 -M-AC PQ3-6.0-M PQ3-6.0 -M-AC	HQ3-8.0-M HQ3-8.0 -M-AC PQ3-8.0-M PQ3-8.0 -M-AC	HQ3-10.0-M HQ3-10.0 -M-AC PQ3-10.0-M PQ3-10.0 -M-AC PQ3-10.0-L-M PQ3-10.0-L -M-AC	HQ3-12.0-M HQ3-12.0 -M-AC PQ3-12.0-M PQ3-12.0 -M-AC	HQ3-15.0-M HQ3-15.0 -M-AC PQ3-15.0-M PQ3-15.0 -M-AC
<b>Backup Output (on grid mode)</b>						
Max. output power for backup load [W]	43470	43470	43470	43470	43470	43470
Max. output current for backup load [A a.c.]	63	63	63	63	63	63
<b>Backup Output (off grid mode)</b>						
Max. apparent AC power [VA]	5000	6000	8000	10000	12000	15000
Peak apparent AC power [VA] (60s)	6000	7200	9600	12000	14400	15000
Rated output voltage [V a.c.]	400V/230VAC; 3L/N/PE					
Rated grid frequency [Hz]	50/60	50/60	50/60	50/60	50/60	50/60
Backup max current (Per phase) [A a.c.]	7.2	8.7	11.6	14.5	17.4	21.7
Power factor	1 (Adjustable from 0.8 leading to 0.8 lagging)					
Parallel operation	Yes @max. 4 PCS					
Switch time	<20ms					
THDV	<3%@Linear Load					

## 4.5 Efficiency and Standard

Models	HQ3-5.0	HQ3-6.0	HQ3-8.0	HQ3-10.0	PQ3-10.0-L PQ3-10.0 -L-AC PQ3-10.0 -L-M PQ3-10.0-L -M-AC	HQ3-12.0	HQ3-15.0
	HQ3-5.0-AC	HQ3-6.0-AC	HQ3-8.0-AC	HQ3-10.0-AC		HQ3-12.0-AC	HQ3-15.0-AC
	HQ3-5.0-M	HQ3-6.0-M	HQ3-8.0-M	HQ3-10.0-M		HQ3-12.0-M	HQ3-15.0-M
	HQ3-5.0 -M-AC	HQ3-6.0 -M-AC	HQ3-8.0 -M-AC	HQ3-10.0 -M-AC		HQ3-12.0 -M-AC	HQ3-15.0 -M-AC
	PQ3-5.0	PQ3-6.0	PQ3-8.0	PQ3-10.0		PQ3-12.0	PQ3-15.0
	PQ3-5.0-AC	PQ3-6.0-AC	PQ3-8.0-AC	PQ3-10.0-AC		PQ3-12.0-AC	PQ3-15.0-AC
	PQ3-5.0-M	PQ3-6.0-M	PQ3-8.0-M	PQ3-10.0-M		PQ3-10.0-L-M	PQ3-15.0-M
	PQ3-5.0 -M-AC	PQ3-6.0 -M-AC	PQ3-8.0 -M-AC	PQ3-10.0 -M-AC		PQ3-10.0-L -M-AC	PQ3-15.0 -M-AC
	<b>Efficiency</b>						
MPPT efficiency	99.90%	99.90%	99.90%	99.90%	99.90%	99.90%	99.90%
Max. Efficiency (PV to AC)	97.80%	97.80%	97.90%	97.90%	97.90%	97.90%	97.90%
European efficiency (PV to AC)	97.00%	97.00%	97.10%	97.30%	97.30%	97.50%	97.50%
<b>Protection</b>							
PV reverse polarity protection	YES						
Battery reverse protection	YES						
Anti-islanding protection	YES						
Output short protection	YES						
Leakage current protection	YES						
Insulation resistor detection	YES						
Over voltage category	III (AC side), II (DC side)						
Reverse connect protection	YES						
Over-current protection /Over-temperature protection	YES						
DC/AC surge protection	Type II (PV)/Type II (AC)						
AFCI protection	optional						
DC switch	YES						

## 4.6 General Data

Dimension and weight	
Dimensions (W*H*D) [mm]	570*420*380
Tolerance (W*H*D) [mm]	±3/±3/±3
Net weight [kg]	42.6±5%
Cooling	Natural <span style="float: right;">FAN cooling</span>
Inverter topology	Non-isolated
Communication interface	Meter,WIFI/4G(optional),Bluetooth,DRM,Ethernet,USB,BMS(CAN),RS485,Ripple control,DRY CONTACT*2
LCD display	HMI
Environment requirements	
Installation	Ground mount
Ingress protection	IP66 (For outdoor use)
Operating temperature range [°C]	-25 to +60°C (Derating at 45°C)
Storage/Operation relative humidity	0%-100% (without condensation)
Altitude [m]	<4000@Derating exceeding 3000m
Protective class	I
Storage temperature	-40 to+70°C
Standby consumption [W]	100W for work,15W for switch off (only PV or battery)
Standby mode	YES
Button	Capacitive touch sensor
Buzzer	1, Inside (Backup&Earth fault)

## Battery Technical Data

### 4.7 EQ3300-S/EQ3300-S (w) Specifications

Specifications for Support-module	
Model No.	EQ3300-S
Max. charge/discharge current (A)	50
Operating charge/discharge temperature (°C)	0~55/-10~55
Storage temperature (°C)	-10~50
Humidity (%)	5~95
Nominal voltage (V)	64
Nominal capacity (Ah)	50
Nominal energy (kWh)	3.2
Battery voltage range (V)	58.0~73.0
Max. Continuous discharge/charge current (A)	50/50
(CC-CV) Standard charging current (A)	25
Constant current and voltage charging cut-off current (A)	2
Depth of discharge(%)	90
Peak discharge current (60s) (A)	65
Altitude (m)	3000
Overall dimensions (W*H*D) (mm)	570*170*380
Tolerance (W*H*D)(mm)	±3/±3/±3
Weight (kg)	36.0±5%
Communication interfaces	CAN

Specifications for Support-module	
Model No.	EQ3300-S (w)
Max. charge/discharge current (A)	50
Operating charge/discharge temperature (°C)	0~55/-10~55 <sup>*1</sup> -25~55/-25~55 <sup>*2</sup>
Storage temperature (°C)	-10~50
Humidity (%)	5~95
Nominal voltage (V)	64
Nominal capacity (Ah)	50
Nominal energy (kWh)	3.2
Battery voltage range (V)	58.0~73.0
Max. Continuous discharge/charge current (A)	50/50
(CC-CV) Standard charging current (A)	25
Constant current and voltage charging cut-off current (A)	2
Depth of discharge(%)	90
Peak discharge current (60s) (A)	65
Altitude (m)	3000
Overall dimensions (W*H*D) (mm)	570*170*380
Tolerance (W*H*D)(mm)	±3/±3/±3
Weight (kg)	36.0±5%
Communication interfaces	CAN
*1warm up function off    *2warm up function on	

Specifications for EQ3300-S/EQ3300-S (w)					
Model No.	EQ3300-S_2S EQ3300-S_2S (w)	EQ3300-S_3S EQ3300-S_3S (w)	EQ3300-S_4S EQ3300-S_4S (w)	EQ3300-S_5S EQ3300-S_5S (w)	EQ3300-S_6S EQ3300-S_6S (w)
Battery designation	IFpP41/149/102 [(20S)2S] E/-10+50/90	IFpP41/149/10 2[(20S)3S] E/-10+50/90	IFpP41/149/102 [(20S)4S] E/-10+50/90	IFpP41/149/102 [(20S)5S] E/-10+50/90	IFpP41/149/102 [(20S)6S] E/-10+50/90
The number of batteries	2	3	4	5	6
Nominal voltage (V)	128.0	192.0	256.0	320.0	384.0
Nominal capacity (Ah)	50	50	50	50	50
Nominal energy (kWh)	6.4	9.6	12.8	16.0	19.2
Battery voltage range (V)	116.0~146.0	174.0~219.0	232.0~292.0	290.0~365.0	348.0~438.0
Max. charge/discharge current (A)	50/50				
(CC-CV) Standard charging current (A)	25				
Constant current and constant voltage charging cut-off current (A)	2				
Peak discharge Current (60s) (A)	65				
Depth of discharge(%)	90				
Storage temperature (°C)	-10~50				
Operating charge/discharge temperature (°C)	0~55/-10~55 <sup>*1</sup> -25~55/-25~55 <sup>*2</sup>				
Discharge capacity (Ah)	35@-10±2°C @1C; 50@25±2°C @1C; 47@55±2°C @1C				
Cycle life	≥6000 @25°C @ 70%SOH				
Ingress protection	IP66				
Protective class	Class I				
Communication interfaces	CAN				
*1warm up function off    *2warm up function on					

## 4.8 EQ4800-S/TQ4800-S Specifications

Specifications for Support-module	
Model No.	EQ4800-S/TQ4800-S
Max. charge/discharge current (A)	50
Operating charge/discharge temperature (°C)	0~55/-10~55
Storage temperature (°C)	-10~35
Humidity (%)	5~95
Normal voltage (V)	44.8
Normal capacity (Ah)	104
Normal energy (kWh)	4.66
Battery voltage range (V)	40.6~51.1
Max. Continuous discharge/charge current (A)	50/50
Short circuit current (kA)	2.5
(CC-CV) Standard charging current (A)	30
Constant current and voltage charging cut-off current (A)	5.3
Depth of discharge(%)	90
Peak discharge current (60s) (A)	65
Altitude (m)	3000
Overall dimensions (W*H*D) (mm)	570*172*380
Tolerance (W*H*D)(mm)	±3/±3/±3
Weight (kg)	39±5%
Communication interfaces	CAN

Specifications for EQ4800-S/TQ4800-S								
Model No.	EQ4800-S_ 2S	EQ4800-S_ 3S	EQ4800-S_ 4S	EQ4800-S_ 5S	EQ4800-S_ 6S	EQ4800-S_ 7S	EQ4800-S_ 8S	EQ4800-S_ 9S
	TQ4800-S_ 2S	TQ4800-S_ 3S	TQ4800-S_ 4S	TQ4800-S_ 5S	TQ4800-S_ 6S	TQ4800-S_ 7S	TQ4800-S_ 8S	TQ4800-S_ 9S
Battery designation	IFpP53/149/ 113[(14S)2S] E/-10+50/90	IFpP53/149/ 113[(14S)3S] E/-10+50/90	IFpP53/149/ 113[(14S)4S] E/-10+50/90	IFpP53/149/ 113[(14S)5S] E/-10+50/90	IFpP53/149/ 113[(14S)6S] E/-10+50/90	IFpP53/149/ 113[(14S)7S] E/-10+50/90	IFpP53/149/ 113[(14S)8S] E/-10+50/90	IFpP53/149/1 13[(14S)9S] E/-10+50/90
The number of batteries	2	3	4	5	6	7	8	9
Nominal voltage (V)	89.6	134.4	179.2	224.0	268.8	313.6	358.4	403.2
Nominal capacity (Ah)	104	104	104	104	104	104	104	104
Nominal energy (kWh)	9.32	13.98	18.64	23.30	27.96	32.61	37.27	41.93

Battery voltage range (V)	81.2 ~102.2	121.8 ~153.3	162.4 ~204.4	203.0 ~255.5	243.6 ~306.6	284.2 ~357.7	324.8 ~408.8	365.4 ~459.9
Max. charge/ discharge current (A)	50/50							
(CC-CV) Standard charging current (A)	30							
Constant current and constant voltage charging cut-off current (A)	5.3							
Peak discharge Current (60s) (A)	65							
Depth of discharge(%)	100							
Storage temperature (°C)	-10~35							
Operating charge/dischar ge temperature (°C)	Charge: 0~55 Discharge: -10~55							
Discharge capacity (Ah)	90@-20±2°C @1/3C ; 104@25±2°C @1C; 104@55±2°C @1C							
Ingress protection	IP66							
Protective class	Class I							
Communicatio n interfaces	CAN							
Standard	IEC 62477-1;IEC 62619							

#### 4.9 EQ5000-S/EQ5000-S (w)/TQ5000/TQ5000 (w)/ EQ5000-S-P (w) Specifications

Specifications for Support-module	
Model No.	EQ5000-S/TQ5000-S
Max. charge/discharge current (A)	50
Operating charge/discharge temperature (°C)	0~55/-10~55
Storage temperature (°C)	-10~50
Humidity (%)	5~95
Nominal voltage (V)	64
Nominal capacity (Ah)	77
Nominal energy (kWh)	4.92
Battery voltage range (V)	58.0~73.0
Max. Continuous discharge/charge current (A)	50/50
(CC-CV) Standard charging current (A)	38.5
Constant current and voltage charging cut-off current (A)	2
Depth of discharge(%)	90
Peak discharge current (60s) (A)	65
Altitude (m)	3000
Overall dimensions (W*H*D) (mm)	570*170*380
Tolerance (W*H*D)(mm)	±3/±3/±3
Weight (kg)	41.0±5%
Communication interfaces	CAN

Specifications for Support-module	
Model No.	EQ5000-S (w)/TQ5000 (w)
Max. charge/discharge current (A)	50
Operating charge/discharge temperature (°C)	0~55/-10~55 <sup>*1</sup> -25~55/-25~55 <sup>*2</sup>
Storage temperature (°C)	-10~50
Humidity (%)	5~95
Nominal voltage (V)	64
Nominal capacity (Ah)	77
Nominal energy (kWh)	4.92
Battery voltage range (V)	58.0~73.0
Max. Continuous discharge/charge current (A)	50/50
(CC-CV) Standard charging current (A)	38.5
Constant current and voltage charging cut-off current (A)	2
Depth of discharge(%)	90
Peak discharge current (60s) (A)	65
Altitude (m)	3000
Overall dimensions (W*H*D) (mm)	570*170*380
Tolerance (W*H*D)(mm)	±3/±3/±3
Weight (kg)	41.0±5%
Communication interfaces	CAN
* <sup>1</sup> warm up function off    * <sup>2</sup> warm up function on	

Specifications for Support-module	
Model No.	EQ5000-S-P (w)
Max. charge/discharge current (A)	50
Operating charge/discharge temperature (°C)	0~55/-10~55 <sup>*1</sup> -25~55/-25~55 <sup>*2</sup>
Storage temperature (°C)	-10~35
Humidity (%)	5~95
Nominal voltage (V)	44.8
Nominal capacity (Ah)	111
Nominal energy (kWh)	4.97
Battery voltage range (V)	40.6~51.1
Max. Continuous discharge/charge current (A)	50/50
(CC-CV) Standard charging current (A)	50
Constant current and voltage charging cut-off current (A)	2.0
Depth of discharge(%)	95
Peak discharge current (60s) (A)	65
Altitude (m)	3000
Overall dimensions (W*H*D) (mm)	570*172*380
Tolerance (W*H*D)(mm)	±3/±3/±3
Weight (kg)	41.0±5%
Communication interfaces	CAN
* <sup>1</sup> warm up function off   * <sup>2</sup> warm up function on	

Specifications for EQ5000-S-P (w)								
Model No.	EQ5000-S -P_2S (w)	EQ5000-S -P_3S (w)	EQ5000-S -P_4S (w)	EQ5000-S -P_5S (w)	EQ5000-S -P_6S (w)	EQ5000-S -P_7S (w)	EQ5000-S -P_8S (w)	EQ5000-S -P_9S (w)
Battery designation	IFpP53/150/1 20[(14S)2S]E/ -10+50 /90	IFpP53/150/12 0[(14S)3S]E/-1 0+50 /90	IFpP53/150/1 20[(14S)4S]E/ -10+50 /90	IFpP53/150/1 20[(14S)5S]E/ -10+50 /90	IFpP53/150/1 20[(14S)6S]E/ -10+50 /90	IFpP53/150/1 20[(14S)7S]E/ -10+50 /90	IFpP53/150/ 120[(14S)8S] E/-10+50 /90	IFpP53/150/1 20[(14S)9S]E/ /-10+50 /90
The number of batteries	2	3	4	5	6	7	8	9
Nominal voltage (V)	89.6	134.4	179.2	224.0	268.8	313.6	358.4	403.2
Nominal capacity (Ah)	111	111	111	111	111	111	111	111
Nominal energy (kWh)	9.94	14.91	19.88	24.85	29.82	34.79	39.76	44.73
Battery voltage range (V)	81.2~102.2	121.8~153.3	162.4~204.4	203.0~255.5	243.6~306.6	284.2~357.7	324.8~408.8	365.4~459.9
Max. charge/discharge current (A)	50/50							
(CC-CV) Standard charging current (A)	50							
Constant current and constant voltage charging cut-off current (A)	2							
Peak discharge Current (60s) (A)	65							
Depth of discharge(%)	95							
Storage temperature (°C)	-10~35							
Operating charge/discharge temperature (°C)	0~55/-10~55 <sup>*1</sup> -25~55/-25~55 <sup>*2</sup>							
Discharge capacity (Ah)	56@-10±2°C @0.5C; 77@25±2°C @0.5C; 73@55±2°C @0.5C							
Cycle life	≥6000							
Ingress protection	IP65							
Protective class	Class I							
Communication interfaces	CAN							
<sup>*1</sup> warm up function off <sup>*2</sup> warm up function on								

Specifications for EQ5000-S/EQ5000-S (w)/TQ5000-S/TQ5000-S (w)					
Model No.	EQ5000-S_2S EQ5000-S_2S (w) TQ5000-S_2S TQ5000-S_2S (w)	EQ5000-S_3S EQ5000-S_3S (w) TQ5000-S_3S TQ5000-S_3S (w)	EQ5000-S_4S EQ5000-S_4S (w) TQ5000-S_4S TQ5000-S_4S (w)	EQ5000-S_5S EQ5000-S_5S (w) TQ5000-S_5S TQ5000-S_5S (w)	EQ5000-S_6S EQ5000-S_6S (w) TQ5000-S_6S TQ5000-S_6S (w)
Battery designation	IFpP40/150/112 [(20S)2S] E/-10+50/90	IFpP40/150/112 [(20S)3S] E/-10+50/90	IFpP40/150/112 [(20S)4S] E/-10+50/90	IFpP40/150/112 [(20S)5S] E/-10+50/90	IFpP40/150/112 [(20S)6S] E/-10+50/90
The number of batteries	2	3	4	5	6
Nominal voltage (V)	128.0	192.0	256.0	320.0	384.0
Nominal capacity (Ah)	77	77	77	77	77
Nominal energy (kWh)	9.84	14.76	19.68	24.60	29.52
Battery voltage range (V)	116.0~146.0	174.0~219.0	232.0~292.0	290.0~365.0	348.0~438.0
Max. charge/discharge current (A)	50/50				
(CC-CV) Standard charging current (A)	38.5				
Constant current and constant voltage charging cut-off current (A)	2				
Peak discharge Current (60s) (A)	65				
Depth of discharge(%)	90				
Storage temperature (°C)	-10~50				
Operating charge/discharge temperature (°C)	0~55/-10~55 <sup>*1</sup> -25~55/-25~55 <sup>*2</sup>				
Discharge capacity (Ah)	90@-20±2°C @1/3C 111@25±2°C @1/3C 111@55±2°C @1/3C				
Cycle life	≥6000 @25°C @ 70%SOH				
Ingress protection	IP66				
Protective class	Class I				
Communication interfaces	CAN				
* <sup>1</sup> warm up function off * <sup>2</sup> warm up function on					

## 4.10 EQ5500-S/TQ5500-S Specifications

Specifications for Support-module	
Model No.	EQ5500-S/TQ5500-S
Max. charge/discharge current (A)	50
Operating charge/discharge temperature (°C)	0~55/-10~55
Storage temperature (°C)	-10~35
Humidity (%)	5~95
Normal voltage (V)	44.8
Normal capacity (Ah)	122
Normal energy (kWh)	5.46
Battery voltage range (V)	40.6~51.1
Max. Continuous discharge/charge current (A)	50/50
Short circuit current (kA)	2.6
(CC-CV) Standard charging current (A)	50
Constant current and voltage charging cut-off current (A)	2.0
Depth of discharge(%)	90
Peak discharge current (60s) (A)	65
Altitude (m)	3000
Overall dimensions (W*H*D) (mm)	570*172*380
Tolerance (W*H*D)(mm)	±3/±3/±3
Weight (kg)	41±5%
Communication interfaces	CAN

Specifications for EQ5500/TQ5500								
Model No.	EQ5500-S_	EQ5500-S_	EQ5500-S_	EQ5500-S_	EQ5500-S_	EQ5500-S_	EQ5500-S_	EQ5500-S_
	2S	3S	4S	5S	6S	7S	8S	9S
	TQ5500-S_	TQ5500-S_	TQ5500-S_	TQ5500-S_	TQ5500-S_	TQ5500-S_	TQ5500-S_	TQ5500-S_
	2S	3S	4S	5S	6S	7S	8S	9S
Battery designation	IFpP53/150/1 20[(14S)2S]E /-10+50/90	IFpP53/150/ 120[(14S)3 S]E/-10+50/ 90	IFpP53/150/1 20[(14S)4S] E/-10+50/90	IFpP53/150/1 20[(14S)5S] E/-10+50/90	IFpP53/150/1 20[(14S)6S] E/-10+50/90	IFpP53/150/1 20[(14S)7S] E/-10+50/90	IFpP53/150/1 20[(14S)8S] E/-10+50/90	IFpP53/150/1 20[(14S)9S] E/-10+50/90
The number of batteries	2	3	4	5	6	7	8	9
Nominal voltage (V)	89.6	134.4	179.2	224.0	268.8	313.6	358.4	403.2
Nominal capacity (Ah)	122	122	122	122	122	122	122	122
Nominal energy (kWh)	10.92	16.38	21.84	27.30	32.76	38.22	43.68	49.14

Battery voltage range (V)	81.2 ~102.2	121.8 ~153.3	162.4 ~204.4	203.0 ~255.5	243.6 ~306.6	284.2 ~357.7	324.8 ~408.8	365.4 ~459.9
Max. charge/ discharge current (A)	50/50							
(CC-CV) Standard charging current (A)	50							
Constant current and constant voltage charging cut-off current (A)	2.0							
Peak discharge Current (60s) (A)	65							
Depth of discharge(%)	100							
Storage temperature (°C)	-10~35							
Operating charge/dischar ge temperature (°C)	Charge: 0~55 Discharge: -10~55							
Discharge capacity (Ah)	97@-20±2°C @1/3C ; 122@25±2°C @1C; 122@55±2°C @1C							
Ingress protection	IP66							
Protective class	Class I							
Communicatio n interfaces	CAN							
Standard	IEC 62477-1;IEC 62619							

### 4.11 Overall Dimensions and Weight for the Stackable AIO System

Stackable AIO Overall dimensions and weight											
Battery Model		The number of batteries		2	3	4	5	6	7	8	9
				2	3	4	5	6	7	8	9
EQ3300-S/ EQ3300-S (w)	Dimensions (W*H*D)(mm)	570*793 *380	570*928 *380	570*1063 *380	570*1198 *380	570*1333 *380	/	/	/		
	Tolerance (W*H*D)(mm)	±3/±6/±3	±3/±9/±3	±3/±12/±3	±3/±15/±3	±3/±18/±3	/	/	/		
	Weight (kg) (+5%)	116.4	152.4	188.4	224.4	260.4	/	/	/		
EQ5000-S/ EQ5000-S(w)/ TQ5000-S/ TQ5000-S (w)	Dimensions (W*H*D)(mm)	570*793 *380	570*928 *380	570*1063 *380	570*1198 *380	570*1333 *380	/	/	/		
	Tolerance (W*H*D)(mm)	±3/±6/±3	±3/±9/±3	±3/±12/±3	±3/±15/±3	±3/±18/±3	/	/	/		
	Weight (kg) (+5%)	126.4	167.4	208.4	249.4	290.4	/	/	/		
EQ4800-S/ TQ4800-S	Dimensions (W*H*D)(mm)	570*797 *380	570*934 *380	570*1071 *380	570*1208 *380	570*1345 *380	570*1482 *380	570*1619 *380	570*1756* 380		
	Tolerance (W*H*D)(mm)	±3/±6/±3	±3/±9/±3	±3/±12/±3	±3/±15/±3	±3/±18/±3	±3/±21/±3	±3/±24/±3	±3/±27/±3		
	Weight (kg) (+5%)	122.4	161.4	200.4	239.4	278.4	317.4	356.4	395.4		
EQ5500-S/ TQ5500-S/ EQ5000-S-P (w)	Dimensions (W*H*D)(mm)	570*797 *380	570*934 *380	570*1071 *380	570*1208 *380	570*1345 *380	570*1482 *380	570*1619 *380	570*1756 *380		
	Tolerance (W*H*D)(mm)	±3/±6/±3	±3/±9/±3	±3/±12/±3	±3/±15/±3	±3/±18/±3	±3/±21/±3	±3/±24/±3	±3/±27/±3		
	Weight (kg) (+5%)	126.4	167.4	208.4	249.4	290.4	331.4	372.4	413.4		

\*Base: Dimensions 570 \* 380 \* 103 mm, Weight 4.4 kg, Height Adjustment Range 73~103 mm.

**Note: All dimensions and weights in the table are for the Stackable AIO (Inverter+Batteries) system.**

# 5 Inverter and Battery Installation

## 5.1 Installation Precautions

### Danger!

- Do not wear loose clothing or jewelry when performing installation work, otherwise there may be a risk of electric shock!
- Before carrying out installation work, make sure that the mechanical strength of the installation location is sufficient to support the weight of the equipment, otherwise a mechanical hazard may result.

### Warning!

All jumper components and component-mounted racks must be properly grounded, with unpainted contact surfaces.

Please strictly observe the following safety tips during installation operations. Otherwise, personal injury or death may occur.

- Installation must be performed properly by a professional under conditions that follow all warning tips.
- Nickel-plated copper is recommended, but aluminum can also be used.
- Remove the oxide layer and apply a suitable antioxidant caulking mix before connecting the aluminum busbar.
- For ease of installation and maintenance, it is recommended that sufficient space be allowed around the equipment: adequate cooling airflow, required clearances, and space needed for cables and cable support structures.

## 5.2 UnPackaging

### Note!

Please open the package in order and do not knock it violently!

The following items must be checked before and after opening the box:

No.	Items
1	Check the appearance for any damage, scratches, dents, etc.
2	Check if all the accessories are included.
3	Check if the nameplate information matches the model of the ordered product.
4	Check the warning label for any damage, scratches, fading, etc.

## Unpacking Precautions

- During storage, the packaging must not be removed. It should only be removed when the equipment is ready for installation.
- Before unboxing, inspect the product's external packaging for any issues such as damage, breakage, moisture, dampness, or deformation.
- During unboxing, check the product and its accessories for surface defects like damage, rust, or dents.

## Packing List

When receiving the goods from the carrier, it is essential to conduct a thorough and careful inspection of the products. Check each received item against the delivery slip. If any items are missing or damaged, the carrier should be notified immediately upon discovery. The packing list is as shown below:

### Inverter Package Box

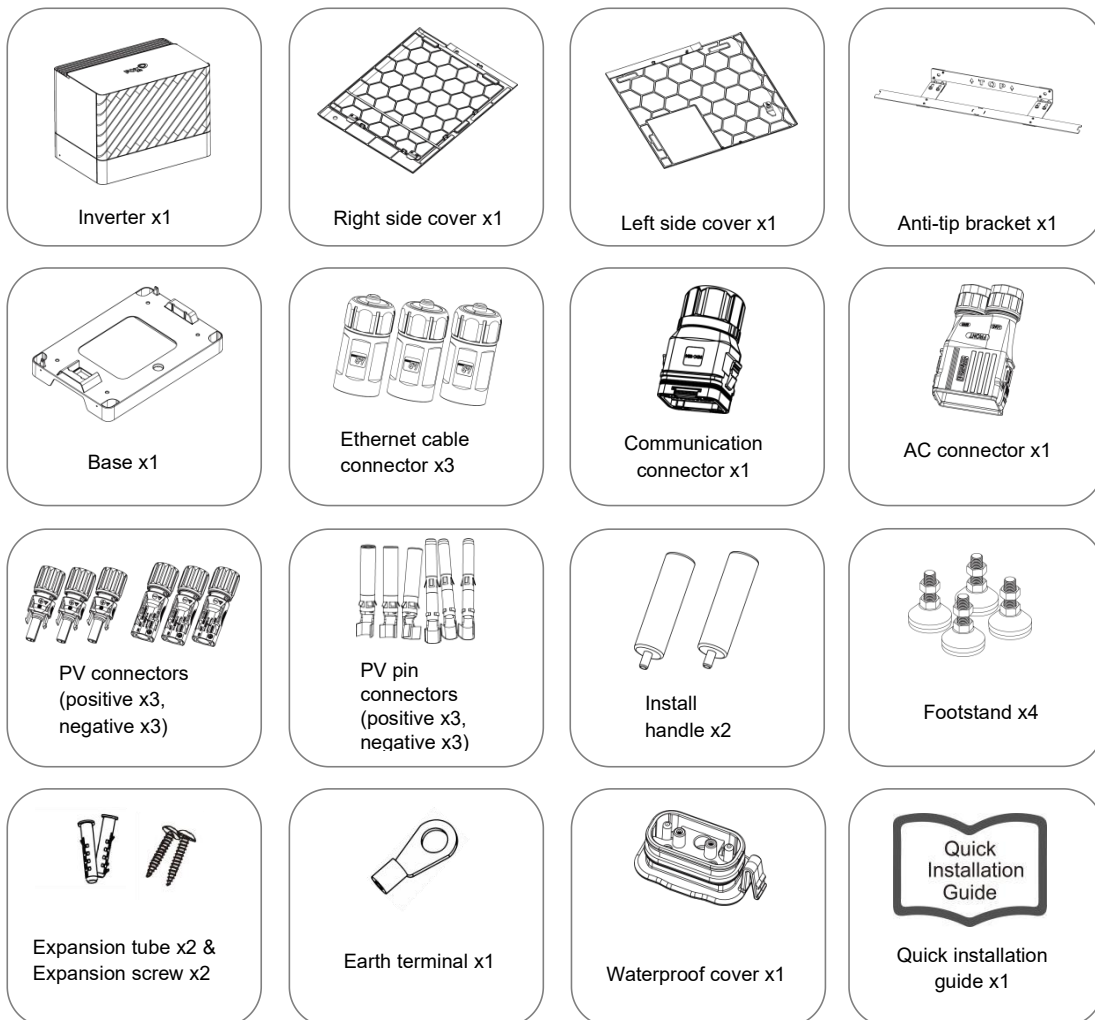

Stackable AIO Series

Inverter and Battery Installation

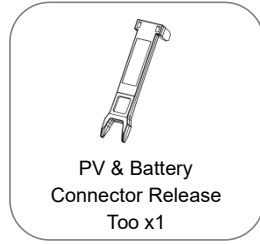
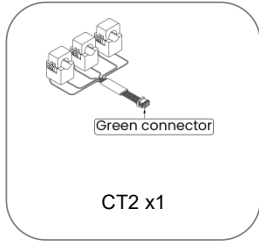
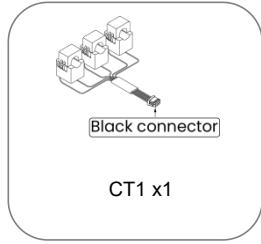
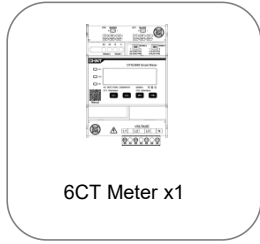

Battery Package Box

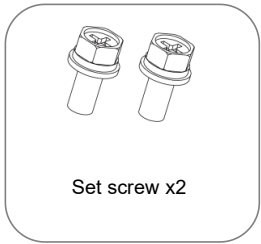
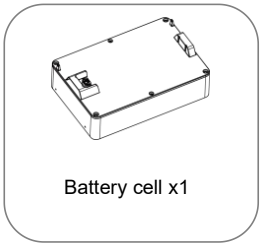

### 5.3 Installation Requirements

Selecting the optimal installation location for the inverter plays a very important role in its safe operation, life assurance and performance guarantee.

#### Environment Requirements

##### **Warning!**

The inverter generates high temperature during operation, so please install it in a location where it cannot be touched by human beings or isolate it by installing a protective net and erecting a safety warning sign on the outside.

##### **Note!**

Site selection should be in accordance with local laws and regulations and relevant standard requirements.

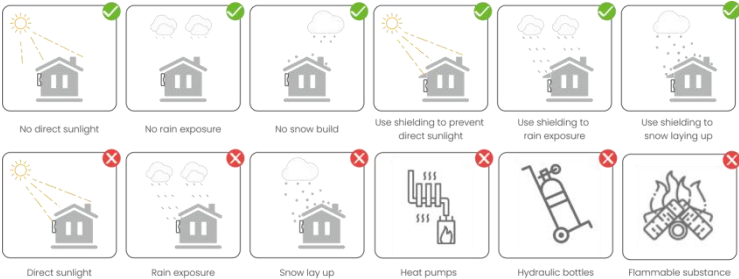
Items	Requirements
Location	<ul style="list-style-type: none"> <li>● Ensure the installation area is protected from direct sunlight, rain, and snow accumulation, a shelter(e.g., rain canopy)is recommended.</li> <li>● Keep the installation area away from high-temperature sources, flammable or explosive materials and other potential explosion hazards such as gas valves, LPG cylinders, heat pumps, firewood stacks, etc.</li> <li>● The installation area must be completely waterproof, with a hard, level floor, and the wall should not have noticeable inclined angle.</li> <li>● Maintain low and stable humidity with good ventilation; dust and dirt within the installation area must be minimized.</li> <li>● Position the installation area away from television antennas or antenna cables to avoid lightning strikes and electromagnetic interference.</li> <li>● Avoid the presence of flammable debris around the battery, such as cotton, fabric, haystacks, etc. which may be ignited by sparks and then lead the fire source to the battery, thus causing the battery to burn.</li> <li>● Avoid the presence of hot or flammable objects around the battery, such as hydraulic bottles natural gas, oxygen, etc.), heat pumps and so on.</li> </ul> <div style="text-align: center;">  </div>

### ⚠ Warning!

The intrusion of moisture can easily cause damage to the equipment! For normal use of the equipment:

- Do not open the cabinet door when the air humidity exceeds 95%.
- Avoid opening the cabinet door, performing maintenance or overhauling, etc., in rainy, lightning or humid weather conditions.

### Installation Surface Requirements

### ⚠ Warning!

Mounting the inverter on a wall that does not meet the specified conditions may cause equipment damage. Any resulting damage will not be covered under the warranty.

### Requirements for the Wall

The wall used for mounting the inverter must meet the following conditions:

- It must be a solid brick/concrete surface or a surface of equivalent strength, and must be capable of bearing the weight.
- If the wall lacks sufficient strength (e.g., column walls or walls with thick decorative coverings), the inverter must be properly supported or reinforced.
- It is strictly prohibited to install the inverter on flammable surfaces or surfaces prone to resonance.
- It should be installed on a wall with good sound insulation to reduce the impact of operational noise.

### Requirements for Foundation

The foundation for the inverter must meet the following conditions:

- The installation surface must be flat, dry, and must be free of standing water.
- Ensure the ground is level, stable (without shaking), and can support the equipment's weight.
- If installed in an area with abundant vegetation, in addition to routine weeding, the ground beneath the equipment must be hardened (e.g., by laying concrete, gravel, etc.) over an area of no less than 3m × 2.5m.

### Requirements for Space

Adequate space must be reserved around the inverter, and a suitable installation angle must be selected to ensure sufficient room for installation and heat dissipation. The specific space requirements for a single inverter are illustrated in the following diagram.

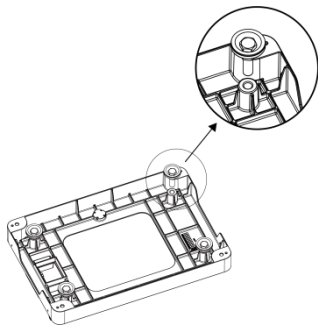

Rotate the four mounts to  
fix them onto the base

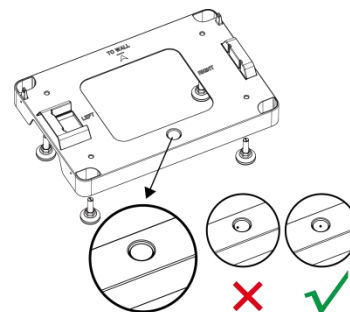

Observe the bubble level to  
ensure the base is placed  
horizontally.

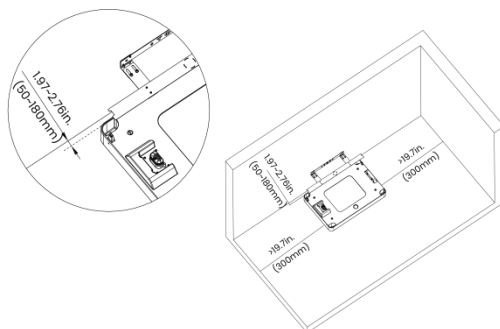

## 5.4 Tools Preparation

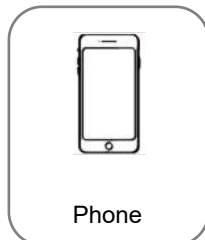
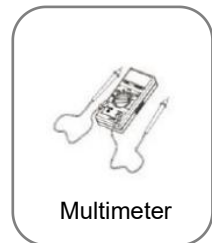
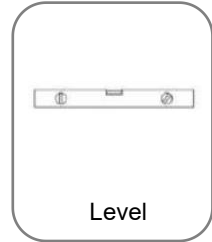
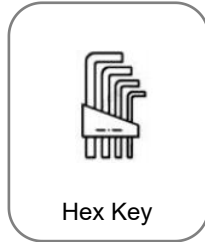

## 5.5 Inverter Handling

- When manually handling the unit, wear protective gloves, safety shoes, and other personal protective equipment to prevent injury during the process.
- Use correct lifting posture: Bend your knees to lower your center of gravity, grasp the inverter handles with both hands, and slowly straighten your knees, using the strength of your legs to lift the load. Keep the load close to your body and move using short, quick steps.
- Always maintain body balance during handling. Avoid making sudden turns or changes in direction.
- If a turn is necessary, execute it slowly and adjust your body posture in advance.
- If you feel fatigued or lack sufficient strength, you must stop handling immediately.

### **Warning!**

Do not jerk or twist your body using the strength of your lower back, as this can lead to injury.

---

## 5.6 Installation Steps

Installation angle requirements: • Do not tilt the energy storage forward, horizontally, upside down, backward and sideways.

Installation space requirements:

When installing energy storage, ensure that there are no other equipment and flammable and explosive materials around, and reserve enough space to ensure the installation heat dissipation and safety isolation requirements. • During wall-mounted installation, no items are allowed to be placed under the energy storage.

Fix the bracket on the wall

Choose the place you want to install the inverter. Place the bracket on the wall and mark the position of the 2 holes from bracket.

### Danger!

Before drilling, please make sure to avoid the water and electricity lines embedded in the wall to avoid danger.

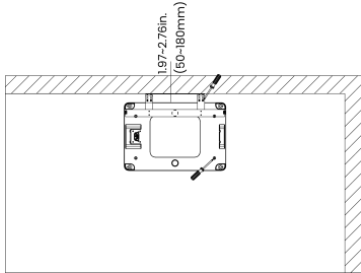
Procedures	
Step 1	Clamp the bracket above the battery base, adjust the distance from the wall, and use a screwdriver to level the feet.
	
Step 2	After removing the bracket from above the battery, stack the battery cells sequentially <b>(up to 9 cells maximum)</b> .
	<p style="text-align: center;"><b>Note!</b></p> <p>Ensure the number of batteries in each system is: 2~9 for EQ4800-S, EQ5500-S, TQ4800-S, TQ5500-S; 2~6forEQ3300-S, EQ3300-S(w), EQ500-S, EQ5000-S(w), TQ5000-S, TQ500-S(w).</p>

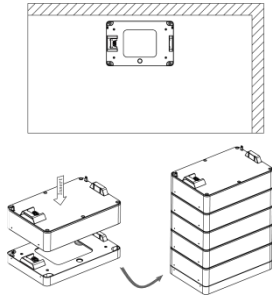
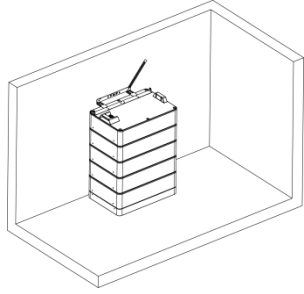
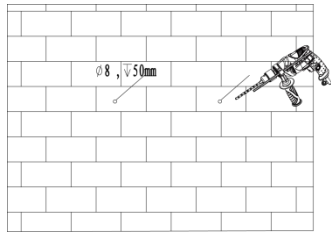
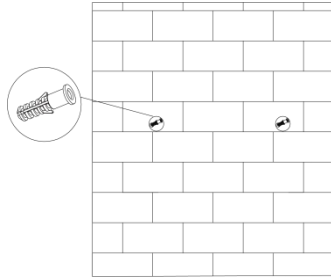
	
<b>Step 3</b>	<p>Once again, secure the bracket onto the top battery cell, and mark the drilling positions on the installation wall.</p> 
<b>Step 4</b>	<p>Drill two 50mm deep holes with an impact drill (<math>\phi 8</math>mm drill bit).</p> 
<b>Step 5</b>	<p>Insert the expansion anchor into the hole.</p> 
<b>Step 6</b>	<p>Use a screwdriver to secure the bracket to the wall.</p>

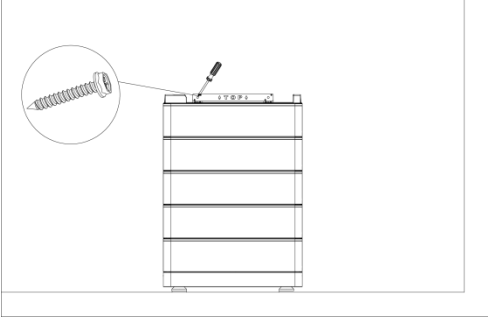
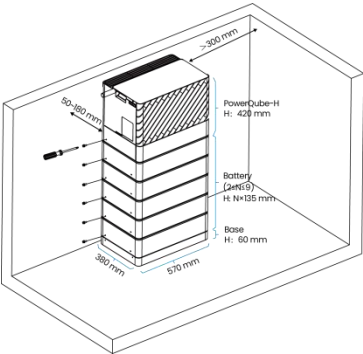
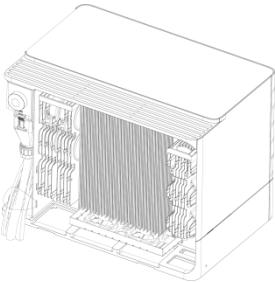
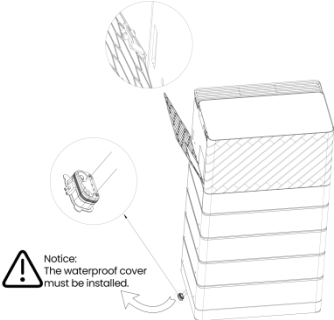
	
<p><b>Step 7</b></p>	<p>Install the handle accessory onto the inverter, stack and move it to the top, then secure by tightening the screws on both sides of the inverter and battery.</p> 
<p><b>Step 8</b></p>	<p>After installing the wire harness in the right-side wiring area, secure it to the inner side with cable ties.</p> 
<p><b>Step 9</b></p>	<p>Align the two buckles with the slots and insert them, then press the side panel flat from the top.</p>  <p><b>Notice:</b> The waterproof cover must be installed.</p>

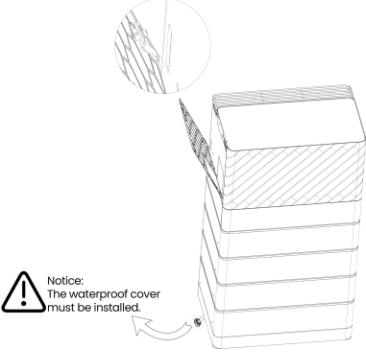
<b>Step 10</b>	Install the left decorative cover by aligning and inserting the clips, then press the side panel flat from the top.
	

**⚠ Warning!**

Operators should wear protective goggles and dust masks to prevent dust from being inhaled into the lungs or falling into the eyes when punching.

**Note!**

The upper face of the expansion tubes must be made sure that it is level with the concrete wall surface and does not protrude from the concrete wall surface, otherwise it will make the wall plate unevenly placed on the wall surface.

# 6 Electrical Connection

## 6.1 Connection Overview

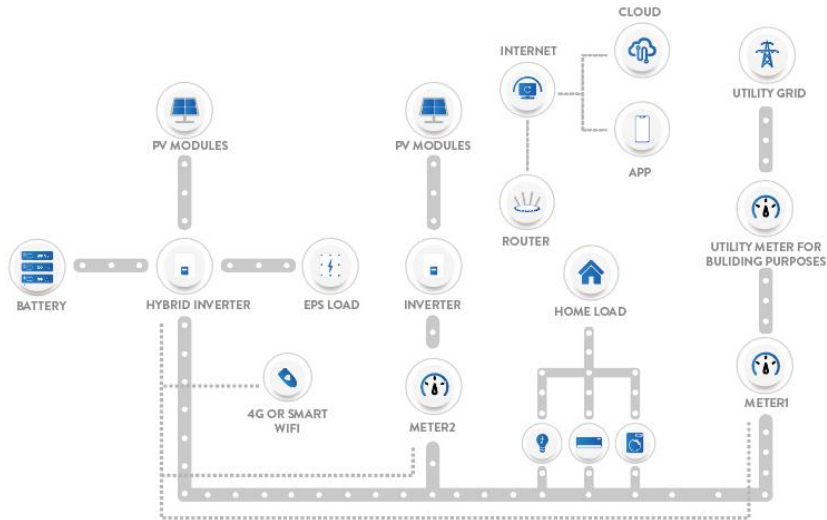

### system overview

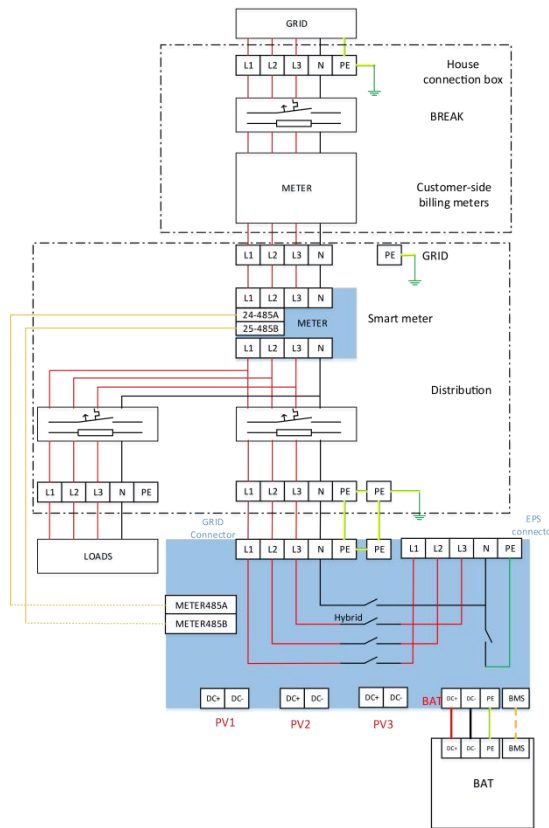

## 6.2 PV Connection

### Step 1: PV String Connection

#### Note!

Please choose a suitable external DC switch if the inverter does not have a built-in DC switch.

#### ⚠ Warning!

PV module voltage is very high and within a dangerous voltage range, please comply with the electric safety rules when connecting.

#### ⚠ Warning!

Please do not make PV positive or negative to ground!

#### Note!

PV modules: Please ensure they are the same type, have the same output and specifications, are aligned identically, and are tilted to the same angle. In order to save cable and reduce DC loss, we recommend installing the inverter as near to the PV modules as possible.

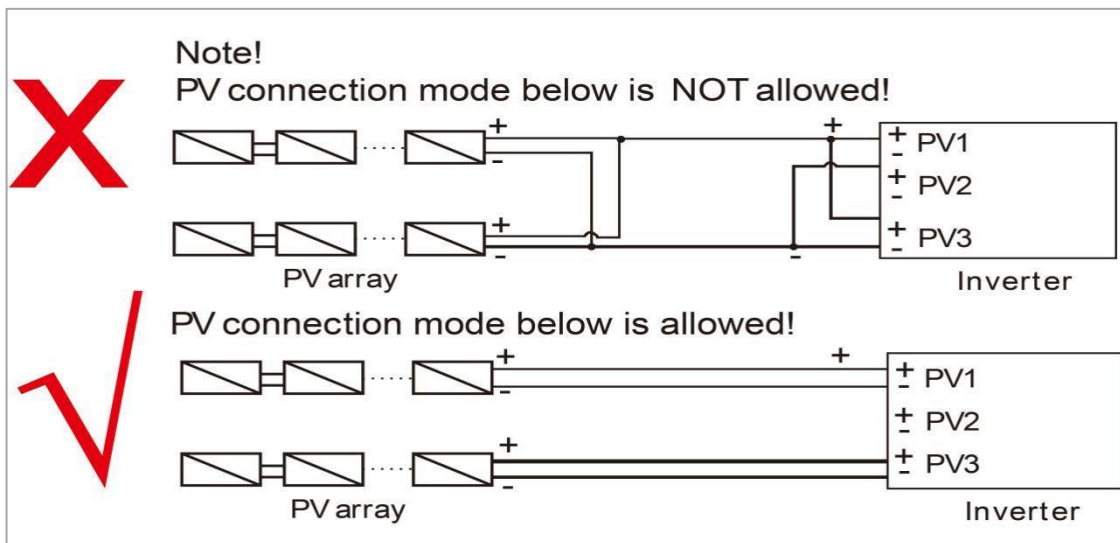

**Step 2: PV Wiring**

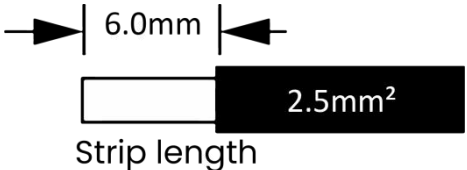
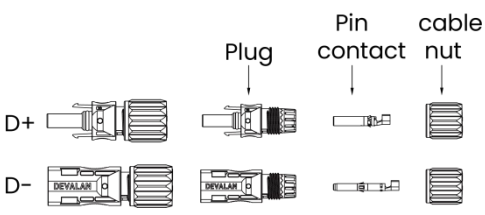
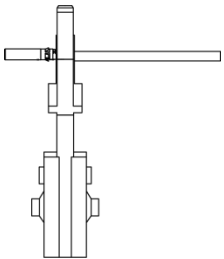
Procedures	
<b>Step 1</b>	<ul style="list-style-type: none"> <li>• Turn off the DC switch.</li> <li>• Choose 2.5mm<sup>2</sup> wire to connect the PV module.</li> <li>• Trim 6mm of insulation from the wire end.</li> </ul> <div style="text-align: center;">  </div>
<b>Step 2</b>	<p>Separate the PV connector as below.</p> <div style="text-align: center;">  </div> <div style="text-align: center; background-color: #cccccc; padding: 5px;"><b>Note!</b></div> <p>When making PV terminals, please make sure that the copper cores of PV positive and PV negative terminals and the copper cores on the inverter can be inserted, and use a multimeter to measure whether the positive and negative terminals are correct, otherwise the machine may not work normally or individual strings may not work.</p>
<b>Step 3</b>	<p>The maximum open-circuit voltage of PV should be less than 900V, otherwise an error may be reported when mppt cannot be traced.</p> <p>Insert striped cable into pin contact and ensure all conductor strands are captured in the pin contact.</p> <p>Crimp pin contact by using a crimping plier. Put the pin contact with striped cable into the corresponding crimping pliers and crimp the contact.</p> <div style="text-align: center;">  </div>
<b>Step 4</b>	<p>Insert pin contact through the cable nut to assemble into back of the male or female plug.</p> <p>When you feel or hear a "click" the pin contact assembly is seated correctly.</p>

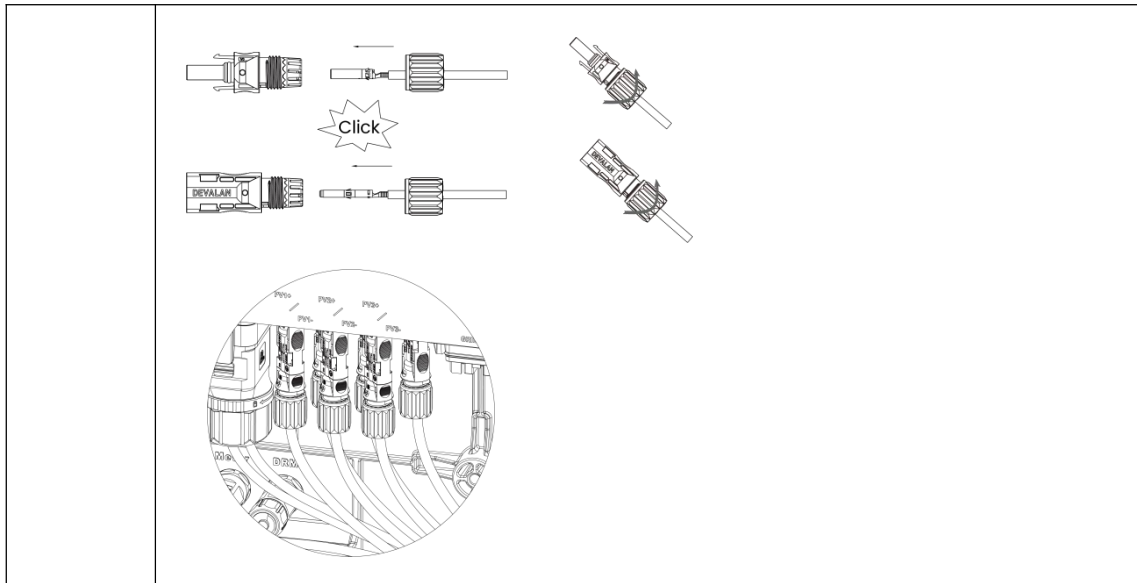

### Unlock the DC connector

#### **⚠ Danger!**

Before separating the DC connector, make sure that there is no current on the DC connector. You can measure it with current clamp or disconnect the DC switch, otherwise serious safety accidents may occur.

Make sure that the power cable connected to the inverter is connected vertically and that the vertical length is greater than 30 cm. If the cable is bent close to the terminals, it may cause poor line contact and result in burnt terminals.

- Use the specified wrench tool.
- When separating the DC + connector, push the tool down from the top.
- When separating the DC - connector, push the tool down from the bottom.
- Separate the connectors by hand.

## 6.3 Grid Connection

### Step 1: Grid String Connection

Hybrid series inverters are designed for three-phase grid. Per voltage range is 220/230/240V; frequency is 50/60Hz. Other technical requests should comply with the requirement of the local public grid.

Model (kW)	HQ3-5.0 HQ3-5.0-AC PQ3-5.0 PQ3-5.0-AC	HQ3-6.0 HQ3-6.0-AC PQ3-6.0 PQ3-6.0-AC	HQ3-8.0 HQ3-8.0-AC PQ3-8.0 PQ3-8.0-AC	HQ3-10.0 HQ3-10.0-AC PQ3-10.0 PQ3-10.0-AC	PQ3-10.0-L PQ3-10.0-L -AC	HQ3-12.0 HQ3-12.0-AC PQ3-12.0 PQ3-12.0-AC	HQ3-15.0 HQ3-15.0-AC PQ3-15.0 PQ3-15.0-AC
Cable (ON-GRID)	6.0mm <sup>2</sup>						
Cable (Backup)	6.0mm <sup>2</sup>						
Micro-Breaker	32A						

Model (kW)	PQ3-5.0-M PQ3-5.0-M-AC HQ3-5.0-M HQ3-5.0-M-AC	PQ3-6.0-M PQ3-6.0-M-AC HQ3-6.0-M HQ3-6.0-M-AC	PQ3-8.0-M PQ3-8.0-M-AC HQ3-8.0-M HQ3-8.0-M-AC	PQ3-10.0-L-M PQ3-10.0-L-M-AC HQ3-10.0-M HQ3-10.0-M-AC	PQ3-12.0-M PQ3-12.0-M-AC HQ3-12.0-M HQ3-12.0-M-AC	PQ3-15.0-M PQ3-15.0-M-AC HQ3-15.0-M HQ3-15.0-M-AC
Cable (ON-GRID)	16.0mm <sup>2</sup>					
Cable (Backup)	16.0mm <sup>2</sup>					
Micro-Breaker	80A					



**⚠ Warning!**

A micro-breaker for max output overcurrent protection device shall be installed between inverter and grid, and the current of the protection device is referred to the table above, any load SHOULD NOT be connected with the inverter directly.

**Step 2: Grid Wiring**

Check the grid voltage and compare with the permitted voltage range (refer to technical data).

Disconnect the circuit-breaker from all the phases and secure against re-connection.

Trim the wires:

Prepare the cable and stripping with the recommended dimension, crimp ferrule for Fine-stranded wire place the wire according to the mark on insert.

\* a stripping tool will be ready soon to make this step easier.

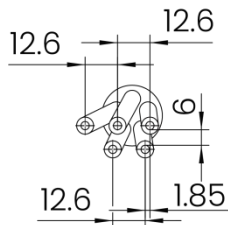
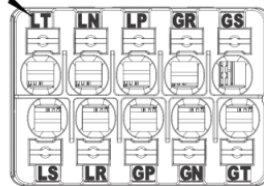

Cable wire type	Single-stranded	Multi-stranded (number of wires ≤ 7)	Fine-stranded
With ferrule	No	No	Yes

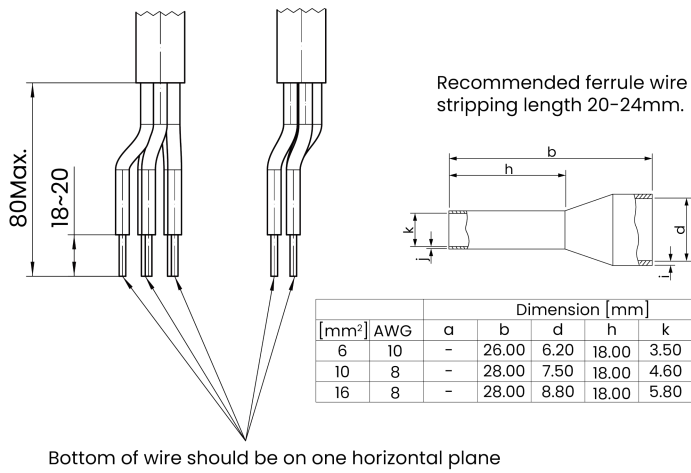

### A. GRID Wiring







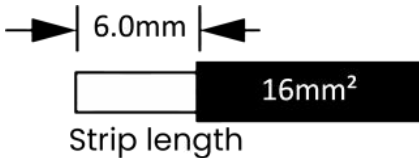
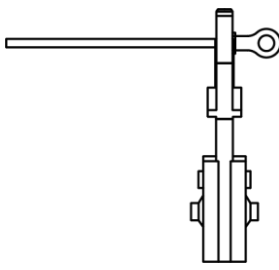
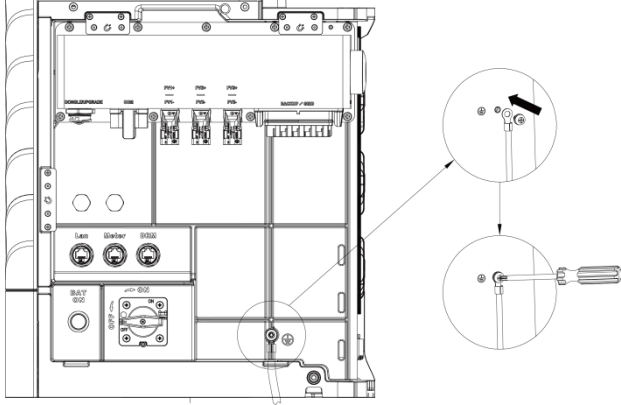

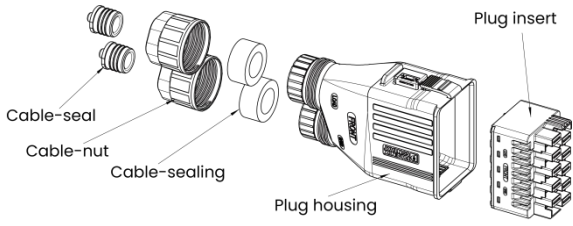
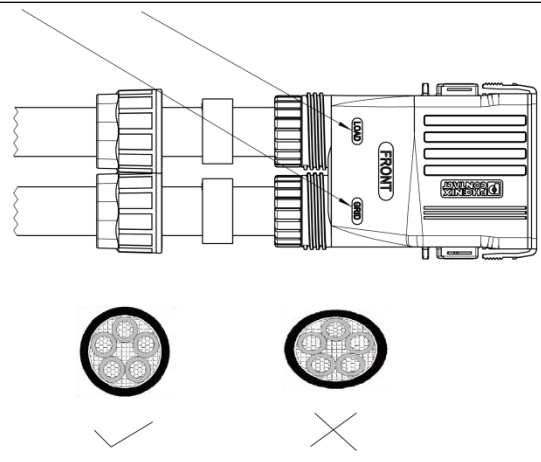

#### Note!

The wiring of the power grid must be connected to the N line, otherwise the machine will report an error and cannot work normally. The SW BUS Volt fault will appear. The method to detect whether the N line is connected is to measure whether the voltage of each phase is within the normal working voltage range separately. Then disconnect one of the live wires and check whether the voltage of the other two phases is within the range. If it is within the range, it means that the N wire is connected. If, after disconnecting the live wire, the voltage of the other two phases changes, it means that the N wire is not connected.

## 6.4 Earth Connection

Procedures	
<p><b>Step 1</b></p>	<p>Trim 6mm of insulation from the wire end.</p> 
<p><b>Step 2</b></p>	<p>Insert striped cable into earth terminal and ensure all conductor strands are captured in the earth terminal.</p> <p>Crimp earth terminal by using a crimping plier. Put the earth terminal with striped cable into the corresponding crimping pliers and crimp the contact.</p> 
<p><b>Step 3</b></p>	<p>Use the crimping pliers to press the ground cable into the ground terminal, screw the ground screw with screwdriver as shown below.</p> 

## 6.5 AC Cable Installation

Procedures													
<b>Step 1</b>	<p>Disassemble parts below from package.</p> 												
<b>Step 2</b>	<p>Get 2 cables through plug nut, cable-sealing, plug-housing, choose right cable-sealing for cable with different diameter. *GRID and LOAD cable should be in right position.</p>  <p>*Make sure that the cable cross-section is circular.</p> <table border="1" data-bbox="454 1355 1029 1478"> <tr> <td></td> <td></td> <td></td> <td></td> </tr> <tr> <td>Sealing color</td> <td>Black</td> <td>Blue</td> <td>Red</td> </tr> <tr> <td>Cable diameter (D)</td> <td>15.4≤D&lt;19</td> <td>19≤D&lt;23.5</td> <td>23.5≤D≤27.5</td> </tr> </table>					Sealing color	Black	Blue	Red	Cable diameter (D)	15.4≤D<19	19≤D<23.5	23.5≤D≤27.5
													
Sealing color	Black	Blue	Red										
Cable diameter (D)	15.4≤D<19	19≤D<23.5	23.5≤D≤27.5										
<b>Step 3</b>	<p>Prepare the cable and stripping with the recommended dimension, crimp ferrule for Fine-stranded wire place the wire according to the mark on insert. * a stripping tool will be ready soon to make this step easier.</p>												

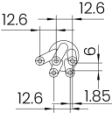

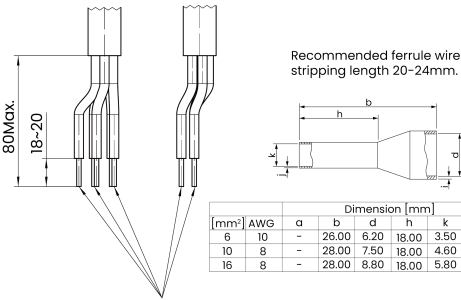

Cable wire type	Single-stranded	Multi-stranded (number of wires≤7)	Fine-stranded
With ferrule	No	No	Yes

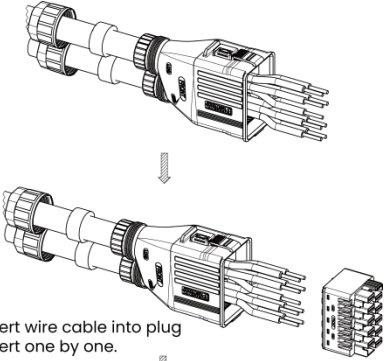

		Dimension (mm)				
[mm <sup>2</sup> ]	AWG	a	b	d	h	k
6	10	-	26.00	6.20	18.00	3.50
10	8	-	28.00	7.50	18.00	4.60
16	8	-	28.00	8.80	18.00	5.80

Bottom of wire should be on one horizontal plane



Insert wire cable into plug  
insert one by one.

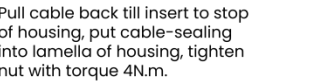

Pull cable back till insert to stop  
of housing, put cable-sealing  
into lamella of housing, tighten  
nut with torque 4N.m.

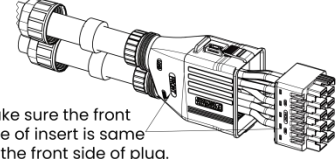

Make sure the front  
side of insert is same  
as the front side of plug.

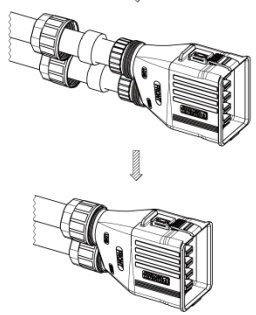

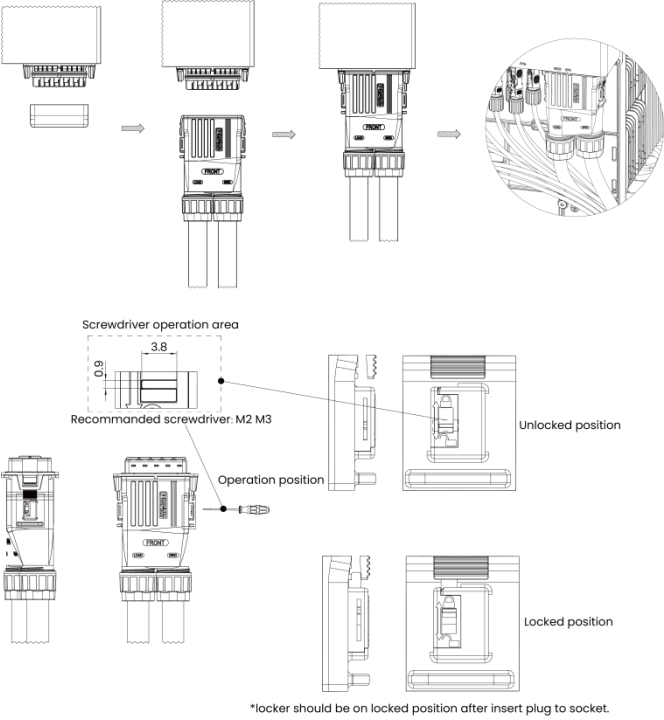
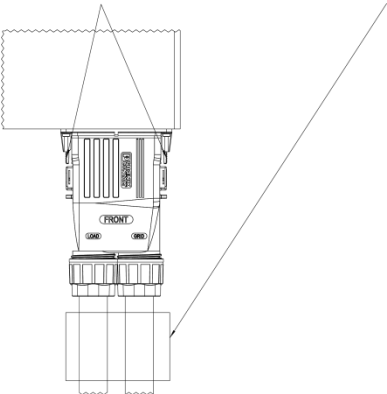
<p><b>Step 4</b></p>	<p>Remove socket cap, mount plug to socket, toggle locker to locked position using screwdriver.</p>  <p>Screwdriver operation area 0.9 3.8 Recommended screwdriver: M2 M3 Operation position Unlocked position Locked position *locker should be on locked position after insert plug to socket.</p>
<p><b>Step 5</b></p>	<p>How to withdraw plug from socket: 1. Make sure the locker is on unlocked position; 2. One hand push the buckles of left and right, one hand pull the wire.</p> 

## 6.6 RJ45 Connection

The machine has three RJ45 terminals, which are meter, Ethernet, and RCR functions

The definition of meter port pin is as follows:

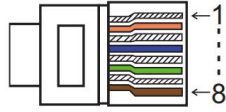

Port \ PIN	1	2	3	4	5	6	7	8
Meter	meter 485B	meter 485A	meter 485A	/	/	meter 485B	/	/

The definition of Ethernet port pin is as follows:

Port \ PIN	1	2	3	4	5	6	7	8
Ethernet	TX+	TX-	RX+	/	/	/	RX-	/

The definition of DRM port pin is as follows:

Port \ PIN	1	2	3	4	5	6	7	8
Ethernet	+3.3V	I/O1	I/O2	I/O3	I/O4	I/O0	GND	GND

## RJ45 Wiring

## Installation Procedure

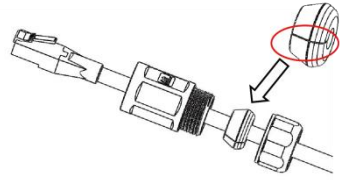
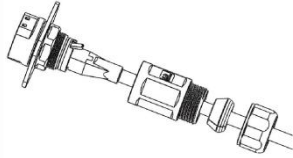
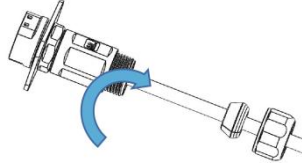
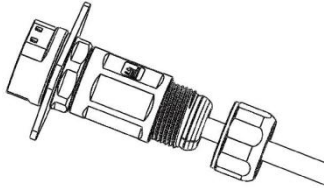
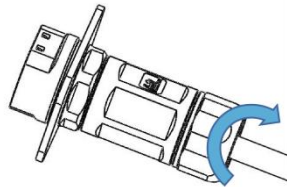
Procedures	
<b>Step 1</b>	<p>Insert the network cable into the wire-locking nut, sealing plug and main body in turn. The sealing plug is stuck into the network cable through the gap on the sealing side.</p>  <p>Stuck into the network cable through the gap on the sealing side.</p>
<b>Step 2</b>	<p>Insert the network cable plug into the matched RJ45 panel mount connector.</p> 
<b>Step 3</b>	<p>Tighten the connector mainbody by the open-ended wrench into the RJ45 panel mount connector with a torque <math>1.2\pm 0.2\text{N}\cdot\text{m}</math>.</p> 
<b>Step 4</b>	<p>Insert the sealing plug into the main body of RJ45 cable end connector.</p> 
<b>Step 5</b>	<p>Tighten the connector's nut by the open-ended wrench with a torque <math>1.2\pm 0.2\text{N}\cdot\text{m}</math>.</p> 

## 6.7 COM Connection

### Introduction to COM port:

The COM port mainly includes EMS485, Meter485, WIFI485, Estop port, two relay output ports, two parallel ports and a toggle switch, +12V and corresponding relay output signals.

The ripple control function is described below.

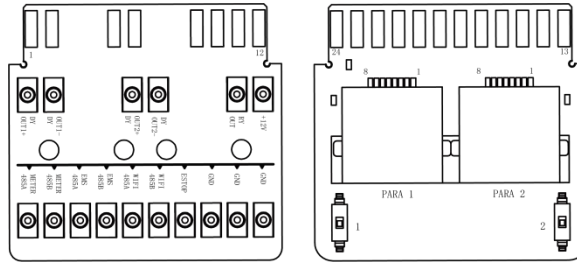

### EMS 485:

Supports Modbus485 communication, which can be used to read and control machines.

The specific protocol is provided by the manufacturer.

### Meter 485:

Similar to the Meter485 interface, this interface is designed to be redundant.

### Wifi 485:

For internal testing.

### Estop port:

When short circuiting ESTOP and GND, the machine will stop working.

**DY OUT:**

The machine has two DY OUT interfaces, with two internal contacts of relays that can drive loads of 230VAC1A/50VDC0.5A, and can be used for powering on and starting heat pumps.

**PARA port RJ45:**

Used for parallel communication, it is necessary to set the DIP switch to the ON state during parallel operation. +12V and RY-Out are used to control external relay switches and cannot be used for other functions.

**24PIN Wiring****Installation Procedure**

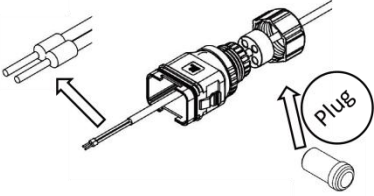
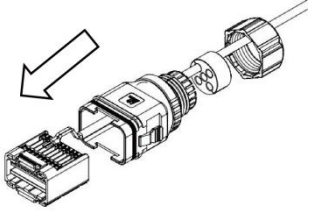
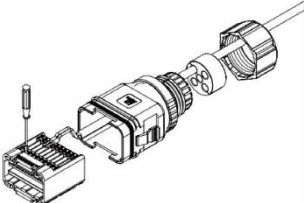
Procedures	
<b>Step 1</b>	<p>Remove the plug inside the plug and thread the terminal according to the sequence shown in the illustration.</p> 
<b>Step 2</b>	<p>Insert the wires into the corresponding terminals.</p> 
<b>Step 3</b>	<p>And use a screwdriver to crimp the wire, screwing torque 1.2+/-0.1N·m.</p> 

<b>Step 4</b>	<p>Arrange the core line, the rubber core area must not appear to ride the line. The rubber core is loaded into the main body and accompanied by a "click" sound.</p>
<b>Step 5</b>	<p>Install the plug into the main body and plug the holes without wires with a plug.</p>
<b>Step 6</b>	<p>Lock wire nut screwed onto the body, torque <math>2.5 \pm 0.1 \text{ N}\cdot\text{m}</math>, then complete installation.</p>

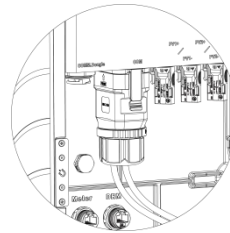
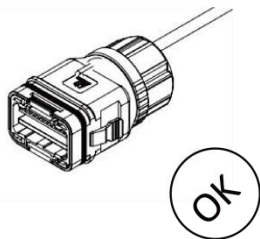
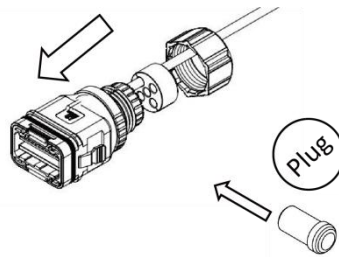
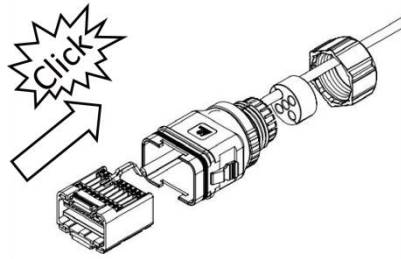

## 6.8 Electrical Connection

### A. Communication Device Installation (Optional)

Hybrid series inverters are available with multiple communication options such as WiFi-, GPRS-, LAN- or 4G-Dongle, RS485 and Smart meter with an external device.

Operating information like output voltage, current, frequency, fault information, etc., can be monitored locally or remotely via these interfaces.

- **WiFi/LAN(internally installed) GPRS (Optional)**

The inverter has an interface for WiFi/GPRS/LAN/4G-Dongle that allow this device to collect information from inverter; including inverter working status, performance etc., and update that information to monitoring platform (the WiFi/GPRS/LAN/4G-Dongle is available to purchase from your local supplier).

#### Connection steps:

1. For GPRS device: Please insert the SIM Card (please refer to the GPRS product manual for more details).
2. Plug the WiFi/ GPRS/ LAN 4G-Dongle into “WiFi/GPRS/LAN 4G-Dongle” port at the bottom of the inverter.
3. For WiFi device: Connect the WiFi with the local router, and complete the WiFi configuration (please refer to the WiFi product manual for more details).
4. Set-up the site account on the monitoring platform (please refer to the monitoring user manual for more details).

#### APP Installation:

Scan the QR Code below to download and install the Cloud APP on your smartphone.



**Configuration:**

Note: The module is powered on and started, please wait for one minute to start the WiFi Config.

Web Configuration.

Step 1:

Connect your mobile device with Smart WiFi. The SSID of the Smart WiFi is 'W-xxxxxxx' and the password is 'mtmt2020' .

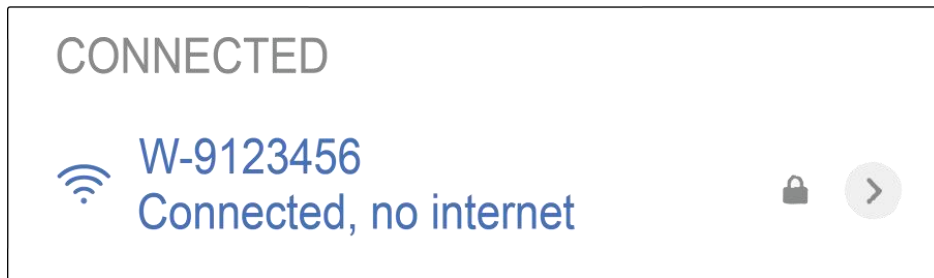

Step 2:

After connecting successfully. Open browser and enter 'https://192.168.1.1' on the address bar on top.

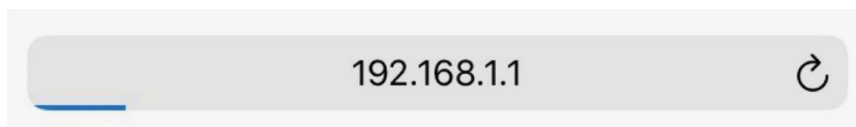

Step 3:

Drop down the WiFi SSID menu to find house router and input the house router's password. Click 'Save' .

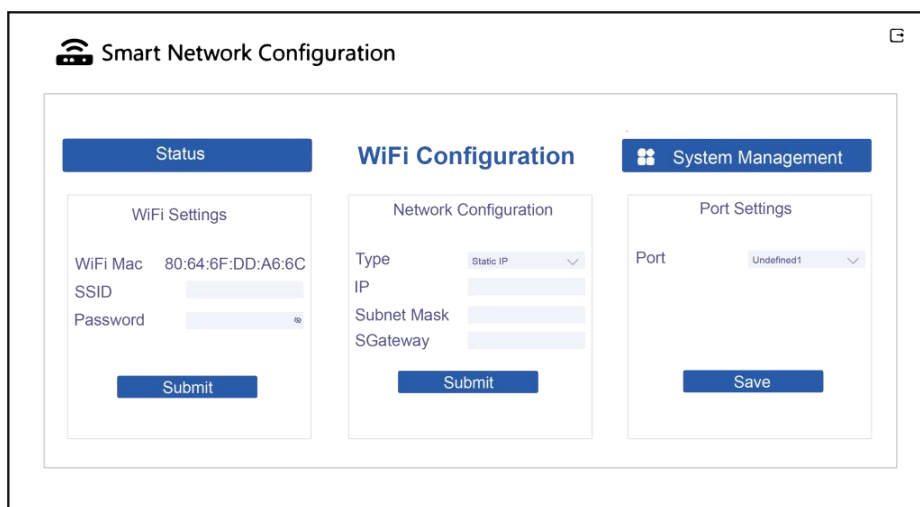

– RS485

RS485 is a standard communication interface which can transmit the real time data from inverter to PC or other monitoring devices.

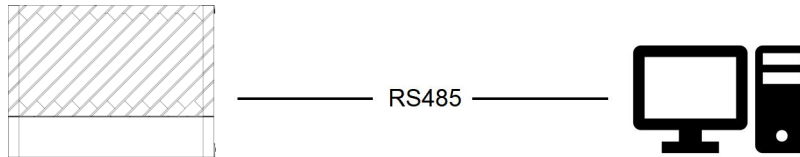

– Meter

The inverter has integrated export limitation functionality. To use this function, a power meter must be installed. For Meter installation, please install it on the grid side.

Note:

- Compatible Meter type: DTSU666 (CHINT).

Please check and configure the meter before use:

**Addr: 1;**

**Baud: 9600**

**Protocol: n.1**

Use the meter that comes standard in the box. Non-standard meters of the same model may not be suitable.

Please refer to the user manual of electricity meter for detailed setting steps.

**Note!**

When connecting the electricity meter, please make sure that the way of the electricity meter is correct, otherwise it will affect the size of the load obtained by the inverter and affect the normal operation of the inverter. When the battery is available and can work normally, the machine provides the self-test function in the direction of the meter, which can be set in the meter interface.

Export control setting:

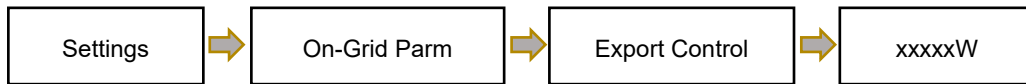

The inverter supports the wiring of various types of electricity meters, including direct-connected meters, 3CT meters, and 6CT meters.

The definition of meter port pin is as follows:

PIN Port	1	2	3	4	5	6	7	8
Meter	meter 485B	meter 485A	meter 485A	/	/	meter 485B	/	/

The electricity meter is connected as follows:

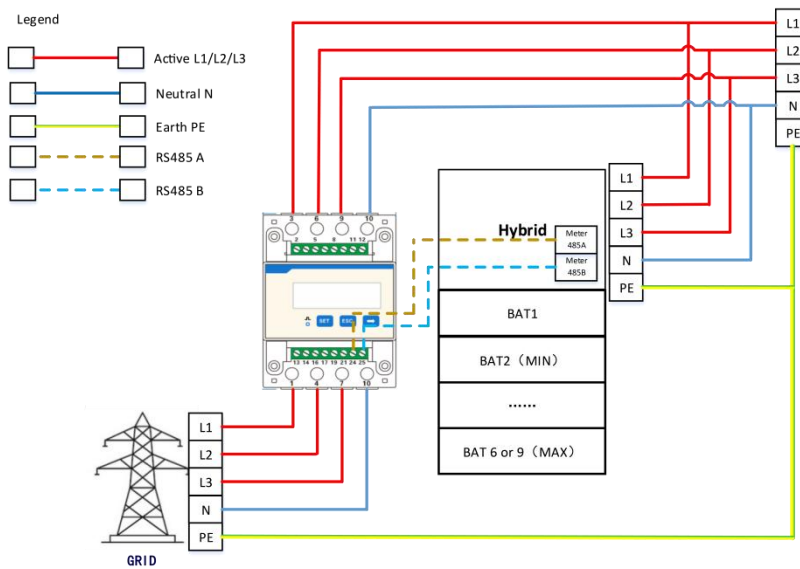

Step 1:

Insert L1/L2/L3/N wires and RS485A/B cable into the meter. Please refer to the meter wiring diagram on side of meter itself.

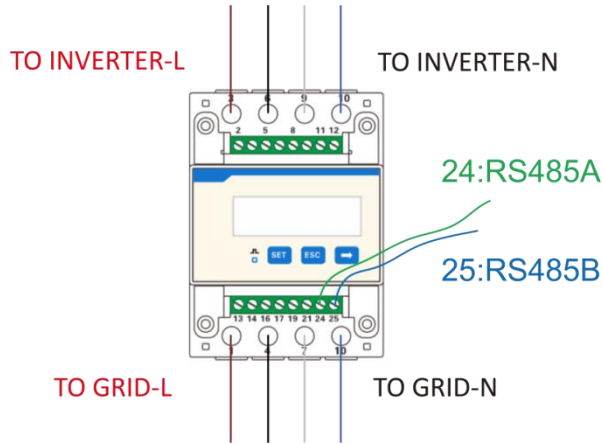

Step 2:

Connect RS485A to pin 2/3 of the inverter METER/RS485 port.

Connect RS485B to pin 1/6 of the inverter METER/RS485 port.

PIN Port	1	2	3	4	5	6	7	8
Meter	meter 485B	meter 485A	meter 485A	/	/	meter 485B	/	/

CT-Meter Type

Step 1:

Insert L1/L2/L3/N wires, CT and RS485A/B cable into the meter. Please refer to the meter wiring diagram on side of meter itself. During CT use, the direction of the CT arrow faces the inverter.

There are different ways of wiring for different grid systems. Four grid types, TT / TN-C-S / TN-C/TN-S are shown as below:

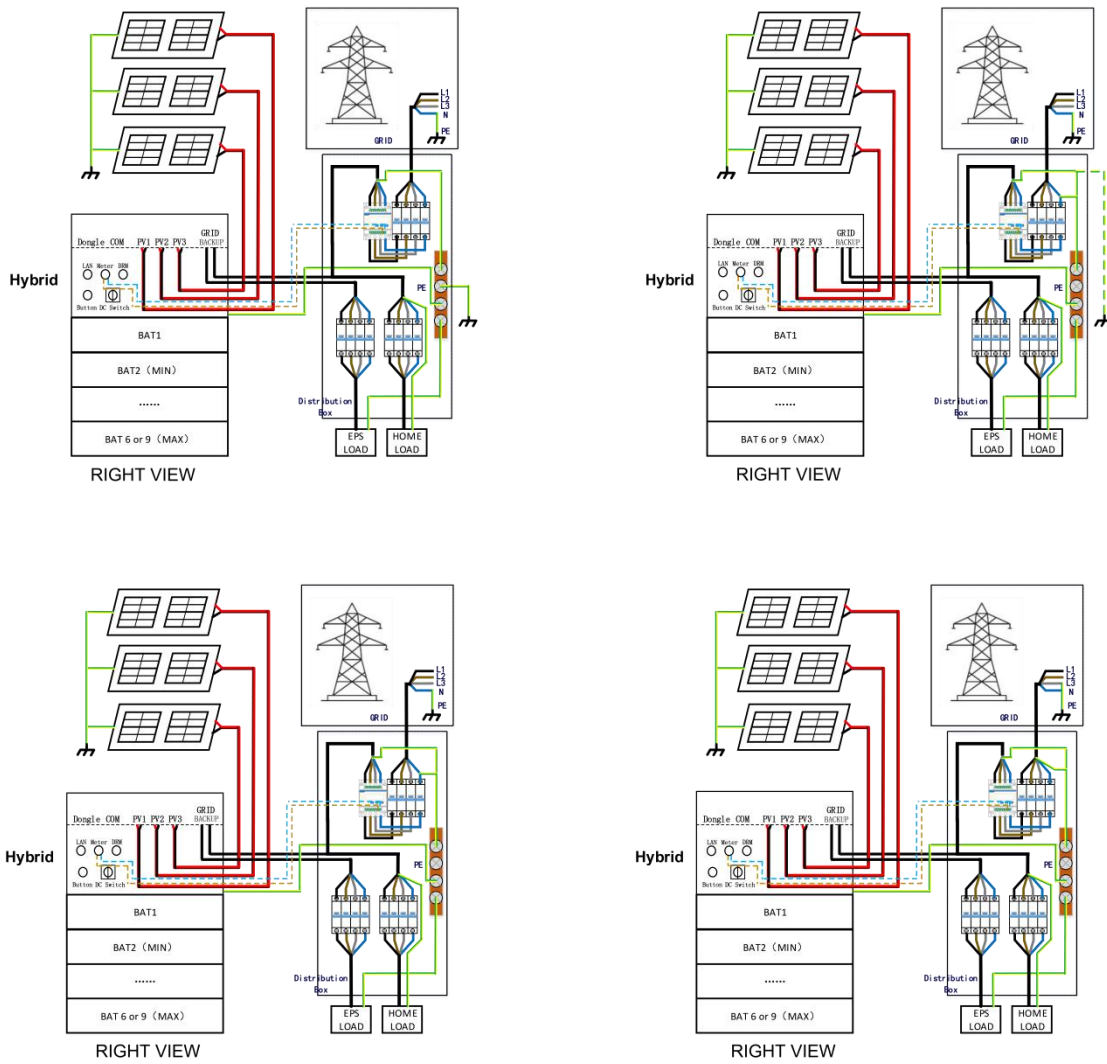

The types of 3CT energy meters

CT-Meter Type

Note:

The electric meter is not included in the attachment and needs to be purchased separately.

Insert L1/L2/L3/N wires, CT and RS485A/B cable into the meter. Please refer to the meter wiring diagram on side of meter itself. During CT use, the direction of the CT arrow faces the inverter.

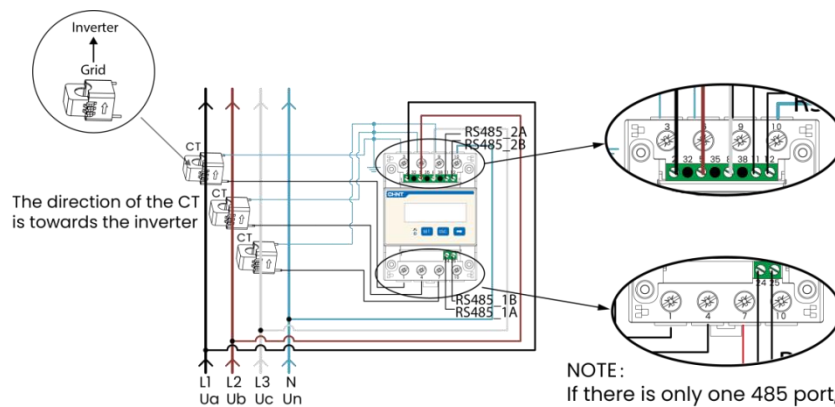
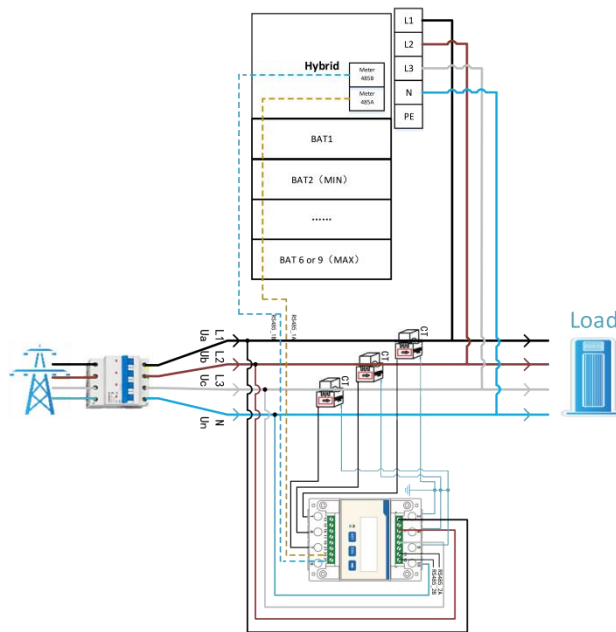

The types of 6CT energy meters

6CT meter enables dual-meter functionality

Step 1:

A 6CT meter can be used to monitor the power output of an additional inverter or generation device.

Step 2:

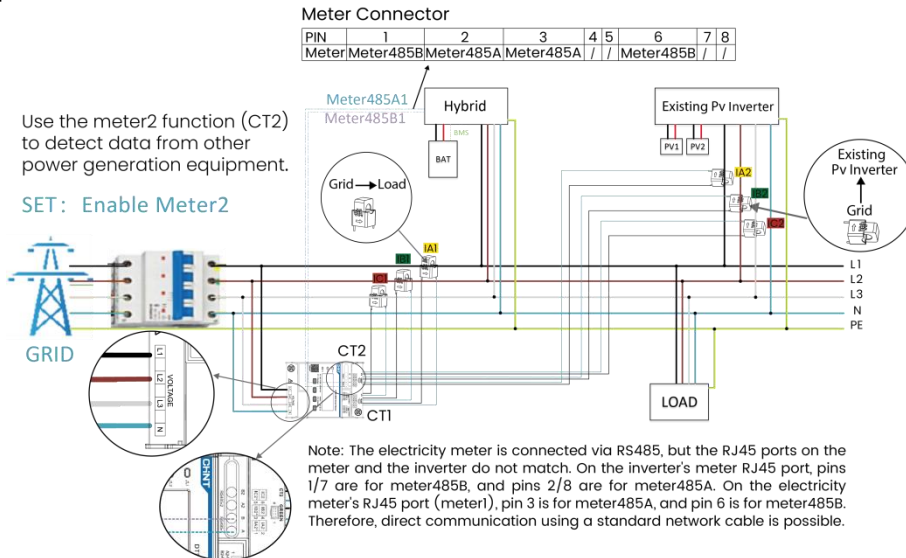

Note:

For the three-phase wiring of the Current Transformer (CT), it must be in phase with the corresponding voltage detection. Specifically, the CT corresponding to the L1 phase is IA, the CT corresponding to the L2 phase is IB, and the CT corresponding to the L3 phase is IC.

Note:

The black power line is connected: the meter terminals L1, IA1 and IA2 should be clamped to the black wire.

The brown power line is connected: the meter terminals L2, IB1 and IB2 should be clamped to the brown wire.

The gray-white power line is connected: the meter terminals L3, IC1 and IC2 should be clamped to the gray-white wire.

Note:

Need to enable meter2

### Method for Checking the Correctness of CT Wiring

In the web-based settings, there is a "meter/CtDetection" interface. On this interface, there is a "DetectionEnable" option. After clicking it, the inverter will automatically check the phase and direction of meter1. The inspection result will be displayed, and you can also set and change the direction of the CT.

#### Local Testing Wiring Method:

Use the AC voltage range of a multimeter to test.

Whether the voltages on the wire of L1 on the electricity meter and the CT (Current Transformer) wire with the yellow sleeve are at the same potential;

Whether the voltages on the wire of L2 on the electricity meter and the CT wire with the green sleeve are at the same potential;

Whether the voltages on the wire of L3 on the electricity meter and the CT wire with the red sleeve are at the same potential.

#### The settings of the electric meter

A password is required to set up the electricity meter. The password is "701",

and the password input process is as follows:

You can change the addr and CT ratio in the settings. Please refer to the electricity meter manual for details.

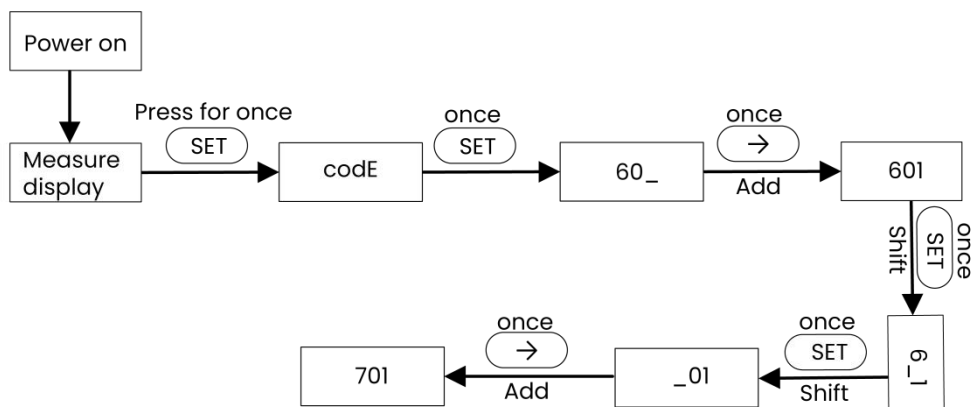

The address of the second meter is 2. Please ensure that the address is 2, otherwise the communication of the first meter will be affected, and the output and monitoring data of the inverter will be affected.

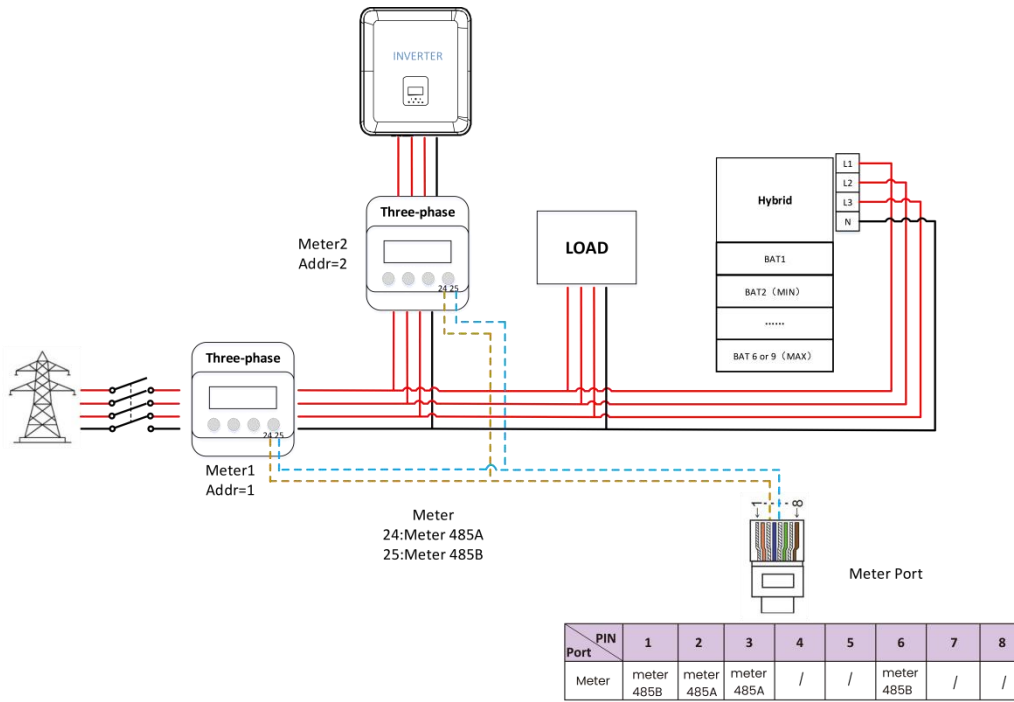

- DRM

The definition of DRM port pin is as follows:

**white rubber ring - old version DRM interface**

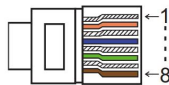

PIN	1	2	3	4	5	6	7	8
Port	REF GEN/0	DRM1/5	DRM2/6	DRM3/7	DRM4/8	COM LOAD/0	GND	GND

**Note:** To achieve the DRM0 function, pins 1 and 6 need to be short-circuited.

The distributors will provide external adapter harnesses which function to convert the old pinout to the new pin definition.

**Note:** The old version of the pin requires an external adapter cable (P/N: 99-100-03722-00) to be compatible with GSD devices.

**Red rubber ring - new version DRM interface**

PIN	1	2	3	4	5	6	7	8
Port	DRM1/5	DRM2/6	DRM3/7	DRM4/8	REF GEN/0	COM LOAD/0	GND	GND

**Note:** To achieve the DRM0 function, pins 5 and 6 need to be short-circuited.

**Note:** The new version supports the 568B cable standard and is directly compatible with GSD devices, eliminating the need for an external converter.

- **BMS**

BMS is used to communicate with the battery for data exchange, please use the network cable configured for the battery to communicate the communication distance should not exceed 10m.

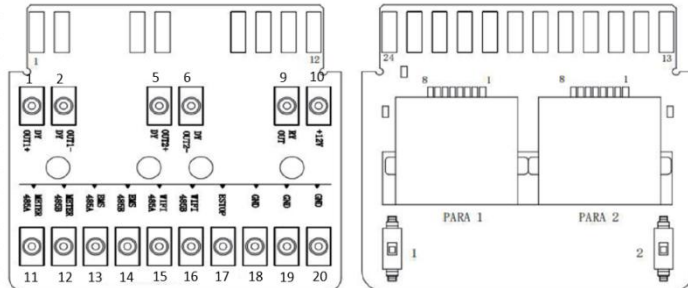

- Insert one side of CAT 7 cable into the first inverter's CAN port and the other side into the next inverter's CAN port.

- Insert one side of CAT 5 cable into the Meter port of meter, and the other side into the CAN 1 port the first inverter or the CAN 2 port of the last inverter.

**Note!**

PV and battery should both be connected to the inverter with meter cable plugged.

Introduction to the function of unbalanced load:

If the load of each phase in the household load is different, and the power of each phase output by the inverter is the same, there will be one phase output and one phase input. In order to avoid this situation, the unbalanced load can be turned on. The use method is to enable in the balance load interface.

The following is a simple schematic diagram of this function :

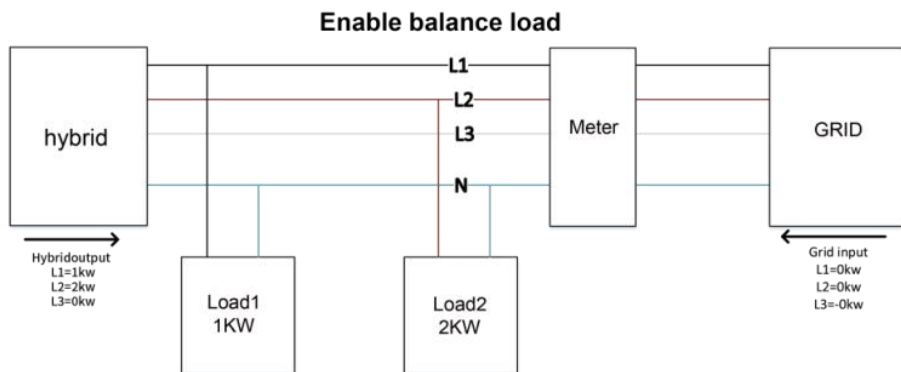
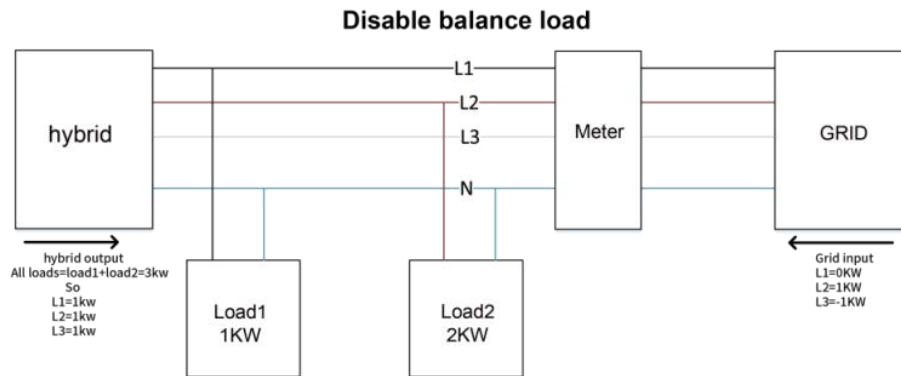









**Note!**

The maximum capacity of balanced load is 1/3 of the rated power, that is, the maximum output capacity of 12kW machine per phase is 4kW. The same is true for unbalanced load of off-grid function. If the single-phase load exceeds 1/3 of the output capacity under off-grid condition, the machine will report an error.

## 6.9 Backup Connection (Non-parallel State)

### Common loads description

Under Backup mode, if need to connect the inductive load on Backup port, please ensure that the instantaneous power of the load at startup is lower than the maximum power of the Backup mode. Below table shows some conventional and reasonable loads for you reference. Please refer to your loads' manual for the actual specs.

Type	Power		Common equipment	Example		
	Start	Rated		Equipment	Start	Rated
Resistive load	X 1	X 1	 Incandescent lamp  TV	 100W Incandescent lamp	100VA (W)	100VA (W)
Capacitive load	X 2	X 1.5	 Fluorescent lamp	 40W Fluorescent lamp	80VA (W)	60VA (W)
Inductive load	X 3~5	X 2	 Fan  Fridge	 150W Fridge	450-750VA (W)	300VA (W)

\*Unipolar load is not supported.

Half-wave load is not supported.

For some motor loads, the starting current may be far more than 5 times the current, which is also not supported.

## 6.10 System Connection Diagrams

For countries such as Australia, New Zealand, South Africa, etc, please follow local wiring regulations.

According to Australian safety requirements, the N cables of the GRID side and Backup side must be connected together. Otherwise, the Backup function will not work.

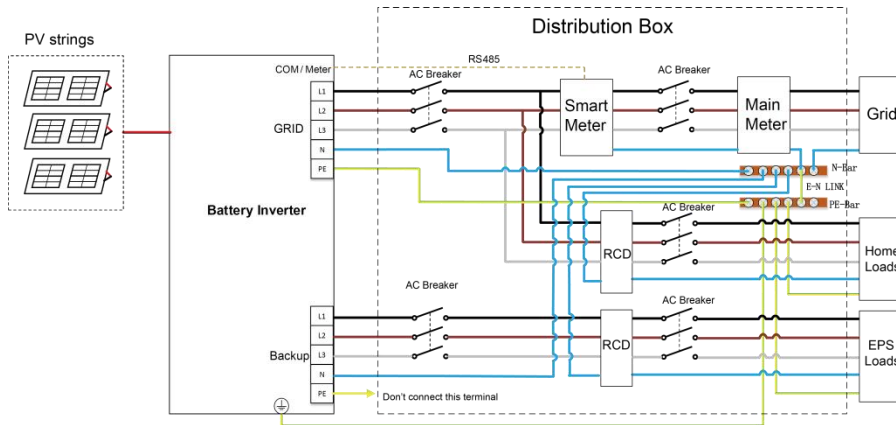

### Note!

Select an MCB with an appropriate rated current based on the actual requirements, including the overall wiring scheme, the number of loads, and the inverter's load-carrying capacity. Selection of an External RCD device, suggest choosing a 30mA RCD (Comply with local regulation), but a RCD with a rating of 30mA may trip at a leakage as 15mA (according to IEC 61008).

### Whole Home Backup Wiring Diagram (Australia and New Zealand)

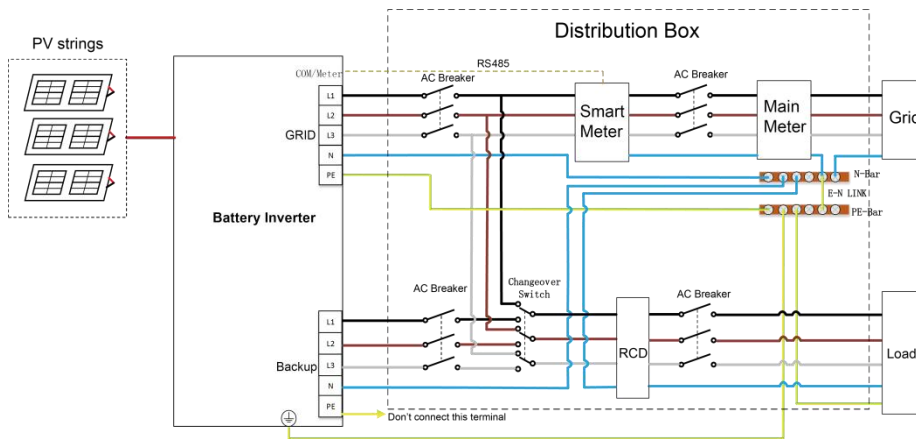

### Note!

1. AC breaker: Depends on loads;
2. RCD: 30mA RCD (Comply with local regulation);
3. Changeover switch: A 63A manual changeover switch is required for the whole home backup scenario. When switching to "Backup" using the changeover switch, household loads will be supplied by the PV installation and battery. When the inverter is faulty or undergoing maintenance, switch to "GRID" to ensure the loads can work normally.

For countries such as China, Germany, the Czech Republic, Italy, etc, please follow local wiring regulations.

This diagram is an example for an application in which neutral is separated from the PE in the distribution box.

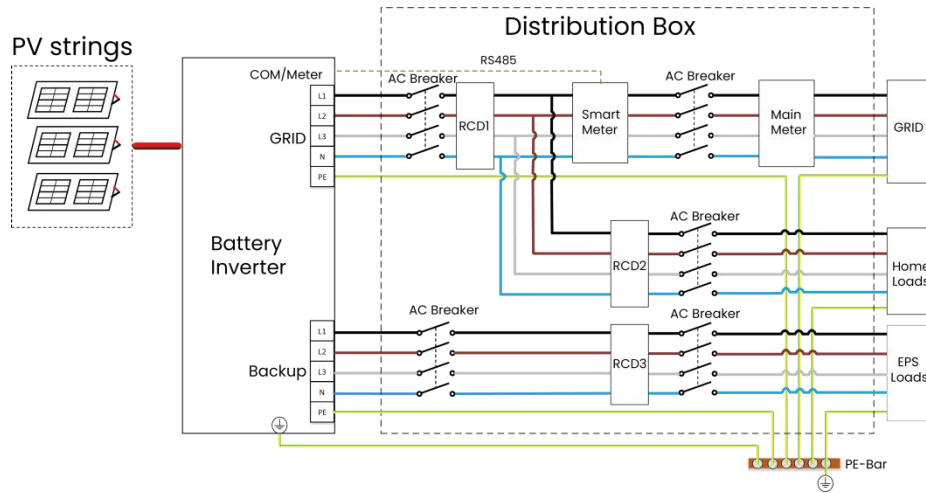

**Note!**

1. Select an MCB with an appropriate rated current based on the actual requirements, including the overall wiring scheme, the number of loads, and the inverter's load-carrying capacity.
2. Select RCD1: 300mA RCD (Comply with local regulation).
3. Select RCD2 and RCD3: 30mA RCD (Comply with local regulation).

Whole Home Backup Wiring Diagram ( China, Germany, the Czech Republic, Italy,etc,)

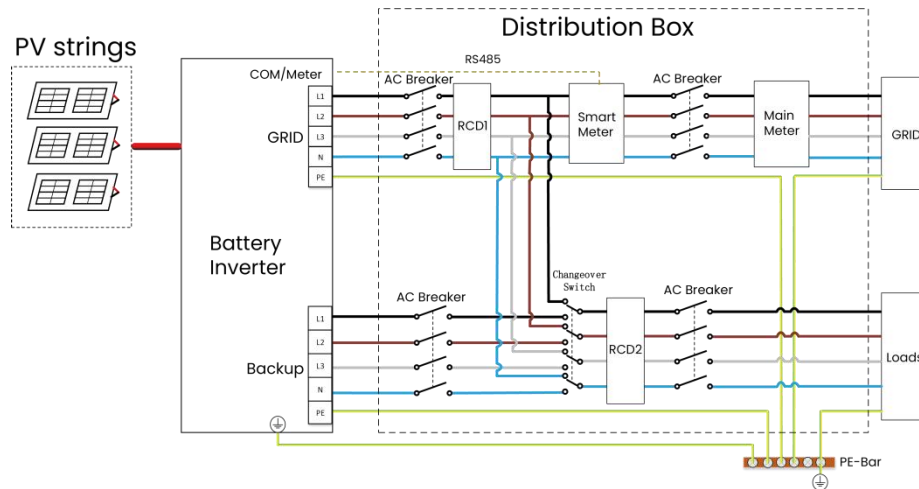

**Note!**

1. Select an MCB with an appropriate rated current based on the actual requirements, including the overall wiring scheme, the number of loads, and the inverter's load-carrying capacity.
2. Select RCD1: 300mA RCD (Comply with local regulation).
3. Select RCD2 and RCD3: 30mA RCD (Comply with local regulation).

## 6.11 Inverter Start-Up

Please refer to the following steps to start up the inverter.

Ensure the inverter fixed well.

Make sure all the DC wirings and AC wirings are completed.

Make sure the meter is connected well.

Make sure the battery is connected well.

Make sure the external Backup contractor is connected well (if needed).

Make sure the BMS buttons and battery switches are off.

Turn on the PV/DC switch (for Hybrid only), AC breaker, Backup breaker and battery breaker.

Enter the settings page, default password is '0000', select START / STOP and set it to start.

### Note!

When starting the inverter for the first time, the country code will be set by default to the local settings.

Please check if the country code is correct.

Set the time on the inverter using the button or by using the APP.

## 6.12 Inverter Switch Off

Please refer to the following steps to switch off the inverter.

1. Enter the settings page, select START / STOP and set it to stop.
2. Turn off the PV/DC switch (for Hybrid only), AC breaker, Backup breaker and battery breaker.
3. Wait 5 min before you open the upper lid (if in need of repair).

# 7 Main Function Implementation

## 7.1 DRM wiring

DRM0 setting

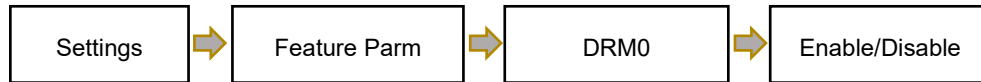

DRM supports several demand response modes by configuring control signals as below.

Mode	Asserted by shorting pins		Requirement
DRM0	VCC	I/O0	Operate the disconnecting device, under Australian safety regulations.
DRM1	I/O1	I/O0	Do not consume power.
DRM2	I/O2	I/O0	Do not consume at more than 50% of rated power.
DRM3	I/O3	I/O0	Do not consume at more than 75% of rated power and source reactive power if capable.
DRM4	I/O4	I/O0	Increase power consumption (subject to constraints from other active DRMs).
DRM5	I/O1	VCC	Do not generate power.
DRM6	I/O2	VCC	Do not generate at more than 50% of rated power.
DRM7	I/O3	VCC	Do not generate at more than 75% of rated power and sink reactive power if capable.
DRM8	I/O4	VCC	Increase power generation (subject to constraints from other active DRMs).

Note: Currently only supports DRM0 function, other functions are under development.

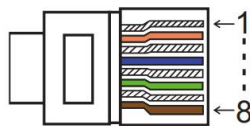

Port \ PIN	1	2	3	4	5	6	7	8
Ethernet	+3.3V	I/O1	I/O2	I/O3	I/O4	I/O0	GND	GND

For the Australian market, only the DRM0 function is supported.

## 7.2 RCR wiring

### RCR setting

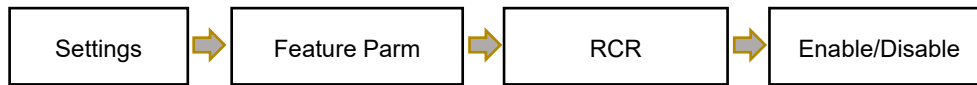

The prerequisite for the use of this function is the selection of the German grid connection regulation VDE 4105 and the use of the RCR function.

On the web page, first determine if the safety regulations are correct.

The settings for ripplr control are as follows on the web page.

Firstly make sure that the ripple control Enable switch is in the Enable state, which indicates that the ripple control function has been turned on. The following K1-K4 Trigger signals function to display the status of ripple control, and K1-K3 power ratio indicates the corresponding power ratio.

For example, when I/O1 and +3.3 V are externally short-circuited, K1TriggerSignal will trigger and Limit the power to 30%.

When K4 is enabled, that is, when I/O4 and +3.3 V are short-circuited, the machine will be off-grid.

For the function of 14a under German safety regulations, there are two ways to operate: hardware and Software. This is the 14a function via the web page, limiting the input power to 4.2kW.

SystemTime
BasicParameters1
OperationMode
ChargingTime
BasicParameters2
RippleControl
ExportLimit
OffGridParameters
SafetyStartParameters
SafetyVoltage
SafetyFrequency
Safety-P(f)
Safety-P(u)
Safety-DCI

\* GridCode

\* Language

\* Meter1

\* Meter2

\* Modbus-RTUAddr  ( 10~99 )

\* Modbus-TCPAddr  ( 10~99 )

\* BuzzerOpen

\* Relay1Switch

\* Relay2Switch

\* 14ASoftwareTrigger

When realizing this through hardware, you need to change the setting in the setup to And external hardware short-circuits I/O0 and +3.3V.

SystemTime
BasicParameters1
OperationMode
ChargingTime
BasicParameters2
RippleControl
ExportLimit
OffGridParameters
SafetyStartParameters
SafetyVoltage
SafetyFrequency
Safety-P(f)

\* DryOut1

\* DryOut2

\* DryIn1

\* DryIn2

\* DryIn3

\* DryIn4

\* DryIn0

The ripple control function is described below:

PIN Port	1	2	3	4	5	6	7	8
Ethernet	+3.3V	I/O1	I/O2	I/O3	I/O4	I/O0	GND	GND

Switching state	Output active power (%Pn)
No contact closed	100%
Several contacts closed	100%
Contact I/O1 to +3.3V	60%
Contact I/O2 to +3.3V	30%
Contact I/O3 to +3.3V	0%
Contact I/O4 to +3.3V	Immediate OFF
Contact I/O0 to 3.3V	AC Max.Chr power limit to 4.2KW under Vde4105 Safty

### 7.3 SG ready wiring and setting

- SG Ready**

The Smart Grid Ready is controlled by the dry contact output 1 of the inverter.

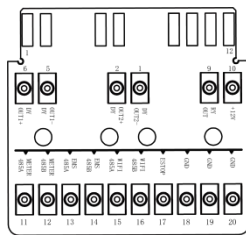

	Relay-1	
<b>Label</b>	DRY_RLY1-	DRY_RLY1+
<b>Mode 1</b>	0	
<b>Mode 2</b>	1	

Note: 0-Relay open, 1-Relay closed

#### Mode 1-Normal operation (0):

The heat pump runs in energy-efficient normal mode.

#### Mode 2-Encouraged operation (1):

The operation of the heat pump is encouraged to increase electricity consumption for heating and warm water.

The controller has 1 control models:

- i) The heat pump is switched on.
- ii) The heat pump is switched on AND the warm water temperature is raised.

## Configure DRY1 as SGready1

DryConfigure setting: DryConfigure Set the DryOut1 to SgReady-1.

SystemTime	* DryOut1	SgReady-1
BasicParameters1	* DryOut2	SgReady-2
OperationMode	* DryIn1	N/A
ChargingTime	* DryIn2	N/A
BasicParameters2	* DryIn3	N/A
RippleControl	* DryIn4	N/A
ExportLimit	* DryIn0	DRM0
OffGridParameters	OK	
SafetyStartParameters		
SafetyVoltage		
SafetyFrequency		
Safety-P(f)		
Safety-P(u)		
Safety-DCI		
Safety-ActiveDispatch		
Safety-Reactive		
AFCI		
AFCISelfTest		
PeakShavingSet		
Operation		
BatteryOperation		
LVRT		
HVRT		
DryConfigure		

## Configure SG ready power management settings

* SgReadyFunction	Disable
* RestartTime	600 ( 0~65535 )s
* SgReadyStartPower	7000 ( 0~60000 )w
StartPower-StopPower >= 1000	
* SgReadyStopPower	1000 ( 0~60000 )w
OK	

\* SgReadyFunction: Disable/Enable sgready function.

\* RestartTime: Interval between two launches of sgready.

\* SgReadyStartPower: when the feed-in power exceeded the set value, the heat pump starts operation.

\* SgReadyStopPower: When the feed-in power is less than the set value, the heat pump stops operation.

**Note!**

Zero-feed-in system, if the pv-generation achieves a predefined value (Mode3), The heat pump will start automatically.

## 7.4 Reactive Function Setting

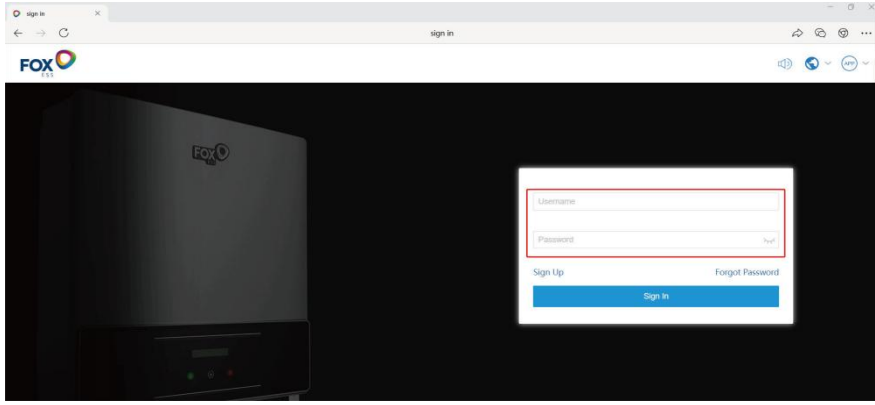
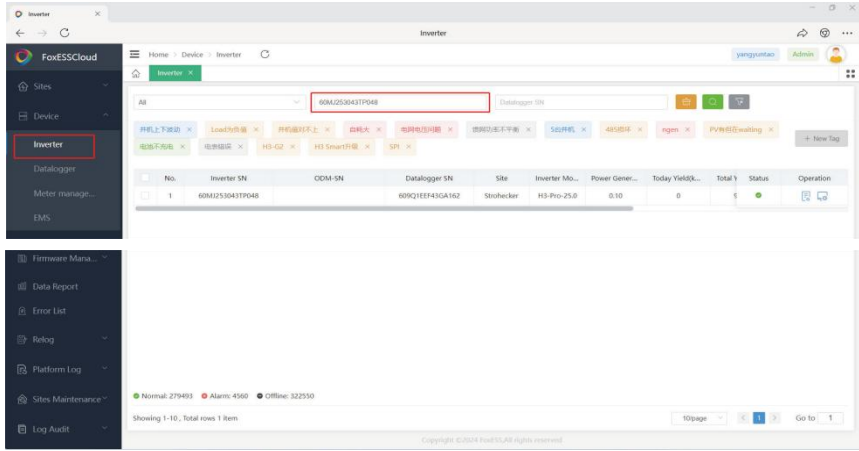
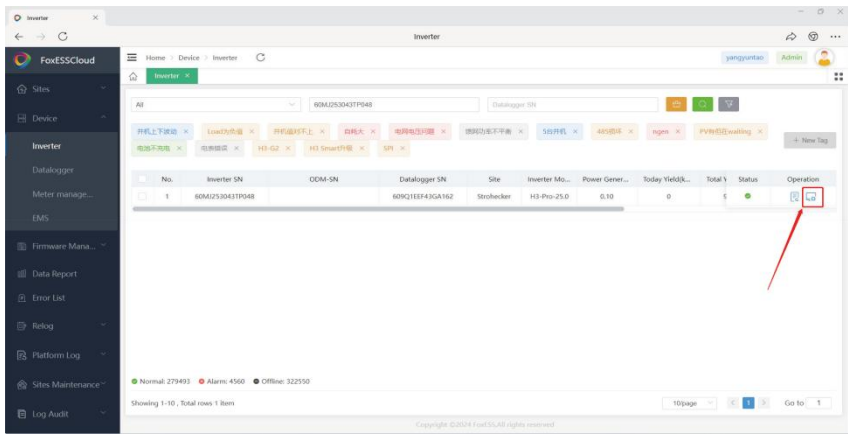
Procedures																							
<b>Step 1</b>	<p style="margin-bottom: 10px;">Login fox Cloud</p> 																						
<b>Step 2</b>	<p style="margin-bottom: 10px;">Enter SN of Inverter</p>  <table border="1" style="width: 100%; border-collapse: collapse; margin-top: 10px;"> <thead> <tr> <th>No.</th> <th>Inverter SN</th> <th>OCM SN</th> <th>Datalogger SN</th> <th>Site</th> <th>Inverter Mo...</th> <th>Power Gener...</th> <th>Today Yield...</th> <th>Total Y</th> <th>Status</th> <th>Operation</th> </tr> </thead> <tbody> <tr> <td>1</td> <td>60M253043TP048</td> <td></td> <td>60K21E8F43GA162</td> <td>Strohecker</td> <td>H3-Pro-25.0</td> <td>0.10</td> <td>0</td> <td>5</td> <td><span style="color: green;">●</span></td> <td></td> </tr> </tbody> </table>	No.	Inverter SN	OCM SN	Datalogger SN	Site	Inverter Mo...	Power Gener...	Today Yield...	Total Y	Status	Operation	1	60M253043TP048		60K21E8F43GA162	Strohecker	H3-Pro-25.0	0.10	0	5	<span style="color: green;">●</span>	
No.	Inverter SN	OCM SN	Datalogger SN	Site	Inverter Mo...	Power Gener...	Today Yield...	Total Y	Status	Operation													
1	60M253043TP048		60K21E8F43GA162	Strohecker	H3-Pro-25.0	0.10	0	5	<span style="color: green;">●</span>														
<b>Step 3</b>	<p style="margin-bottom: 10px;">Click Here</p> 																						

**Step 4**

Click Safety-Reactive, Select the Reactive Power Mode Enable button.

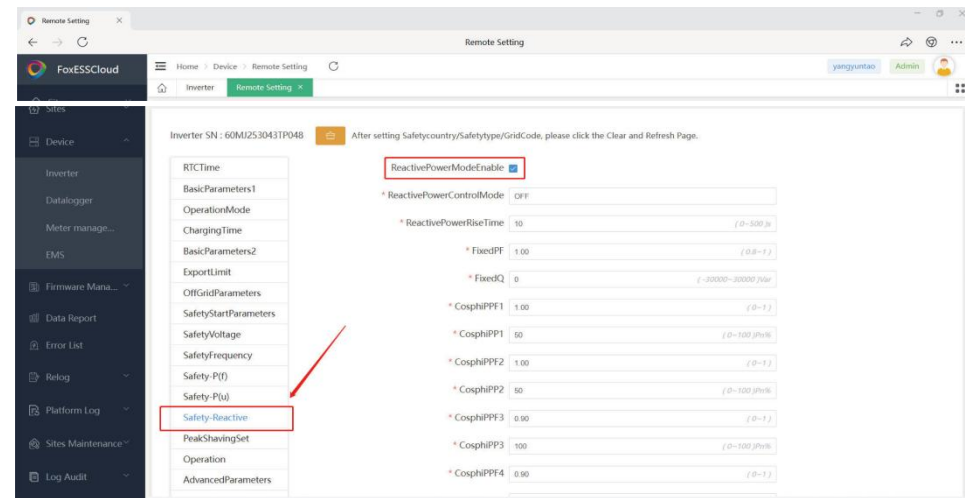
**1. Fixed PF Over**

If you want set the fix PF over, Find the Reactive PowerControl Mode dropdown menu and select the FixedPFOver option;

Set fixed PF parameters according to your needs, with a default value of 1;

\* ReactivePowerControlMode

\* ReactivePowerRiseTime  (0~500)s

\* FixedPF  (0.8~1)

**2. Fixed PF Under**

If you want set the fix PF Under, Find the Reactive PowerControl Mode dropdown menu and select the FixedPFUnder option;

Set fixed PF parameters according to your needs, with a default value of 1;

\* ReactivePowerControlMode

\* ReactivePowerRiseTime  (0~500)s

\* FixedPF  (0.8~1)

### 3. P and cosφ function setting

If you want set the P and cosφ, Find the Reactive PowerControl Mode dropdown menu and select the cosφ (P);

You only need to set the following parameters (CosphiPPF1-4,CosphiPP1-4) according to your needs;

ReactivePowerModeEnable	<input checked="" type="checkbox"/>
* ReactivePowerControlMode	cosφ(P)
* ReactivePowerRiseTime	10 (0~500)s
* FixedPF	1.00 (0.8~1)
* FixedQ	0 (-30000~30000)Var
* CosphiPPF1	1.00 (0~1)
* CosphiPP1	50 (0~100)Pn%
* CosphiPPF2	1.00 (0~1)
* CosphiPP2	50 (0~100)Pn%
* CosphiPPF3	0.90 (0~1)
* CosphiPP3	100 (0~100)Pn%
* CosphiPPF4	0.90 (0~1)
* CosphiPP4	100 (0~100)Pn%

### 4. Fixed Q

If you want set the fix Q, Find the Reactive PowerControl Mode dropdown menu and select the FixedQ option;

Set fixedQ parameters according to your needs;

ReactivePowerModeEnable	<input checked="" type="checkbox"/>
* ReactivePowerControlMode	FixedQ
* ReactivePowerRiseTime	10 (0~500)s
* FixedPF	1.00 (0.8~1)
* FixedQ	0 (-30000~30000)Var

## 5. Q and U function setting

If you want set the Q and U, Find the Reactive PowerControl Mode dropdown menu and select the Qu;

You only need to set the following parameters (QuV1-4,QuQ1-4) according to your needs;

ReactivePowerModeEnable

\* ReactivePowerControlMode

* QuV1	207.0	( 200~300 )V
* QuQ1	30.0	( -50~50 )%
* QuV2	220.0	( 200~300 )V
* QuQ2	0.0	( -50~50 )%
* QuV3	244.0	( 200~300 )V
* QuQ3	0.0	( -50~50 )%
* QuV4	255.0	( 200~300 )V
* QuQ4	-30.0	( -50~50 )%

## 7.5 Implementation of dual-channel Backup function

Note: For the dual-channel Backup function required in some areas, in the off-grid situation, it can allow the customers to turn on and turn off the off-grid additional loads, and provide the settings of turning on and turning off by adjusting the battery capacity.

### Wiring diagram for dual Backup

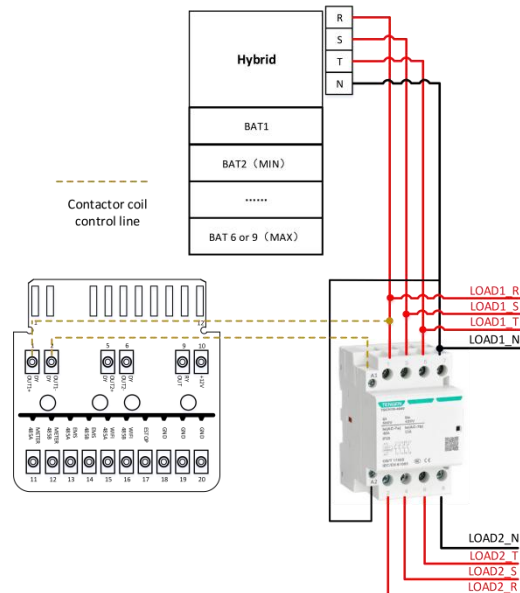

Load1 is directly connected to the Backup port and only loses power when the Backup stops outputting. Load2 is connected after the contractor and will shut off once the SOC drops below a certain level, causing the contractor to disconnect.

Contractor disconnected SOC parameter: SOC \_ split

Contractor connected SOC parameter: SOC \_ return

Relationship:  $\text{min soc} < \text{soc\_split} < \text{soc\_return} < \text{max soc}$

Difference: SOC \_ return between SOC \_ split is at least greater than 10%

Contractor disconnected Logic:

In Backup mode:  $\text{SOC} < \text{SOC\_split}$

Contractor connected logic:

1. In Backup mode:  $\text{SOC} > \text{SOC\_return}$

2. In the case the grid is on or restored and the bypass relay is connected,

eg:

Set SOC \_ split = 60%, SOC \_ return = 80%

It means that in Backup mode, if the current SOC drops below 60%, disconnect the relay and the Load2; if the current SOC returns to more than 80%, connect the relay and the Load 2 or connect the relay when the power grid is restored.

The setting interface: Feature----Dry Contact Ctrl-----Dry1-----1.Smart Load

Ctrl-----Function ON (Yes/No) / SOC OFF / SOC Restore

## 7.6 Parallel connection wiring and operating instructions

Each Stackable AIO series system support Max. 10 units parallel connection for on-grid system or Max.

4 units parallel connection for off-grid system.

### 1) System Diagram

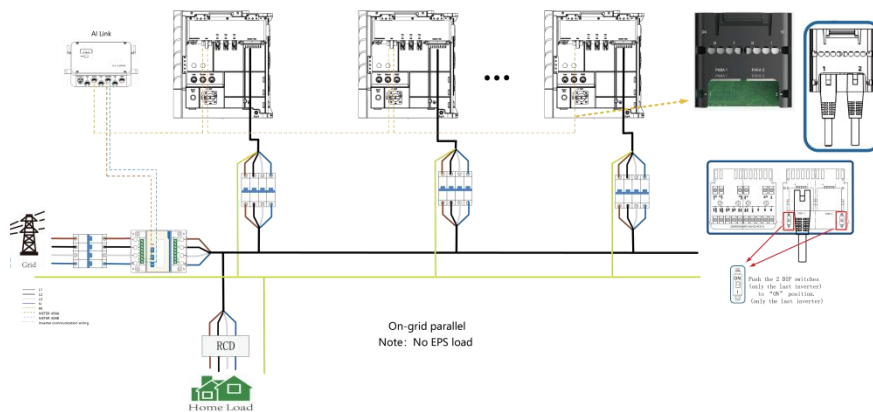
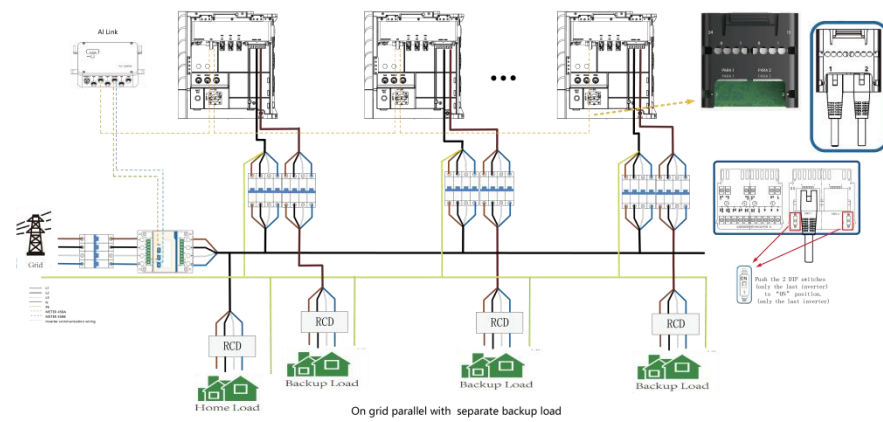
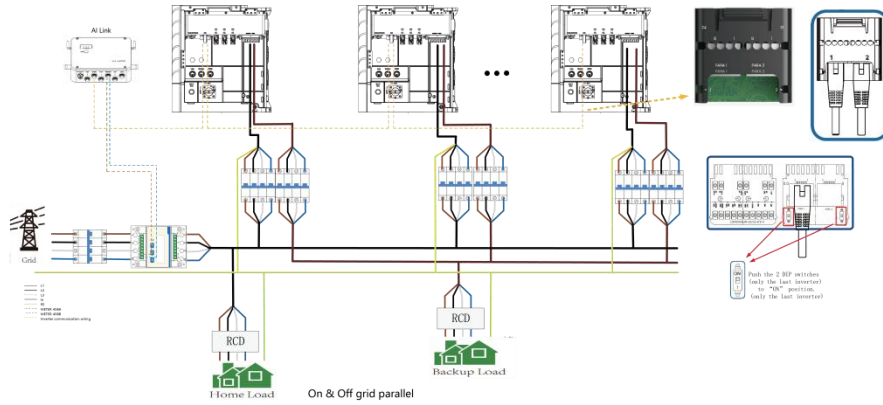

**Note!**

- 1) Parallel inverters need to be of the same type and same version of software.
- 2) For "On grid parallel with Backup load" , "On&off grid parallel " scene, each inverter must be connected to the battery.
- 3) The cable length from each inverter's grid port to the grid connection point must be the same, and the cable length from each inverter's Backup port to the common load connection point must also be the same.

**2) Wire Connection**

Procedures	
<b>Step 1</b>	<p>Parallel Power wiring</p> <p>Please select the corresponding power wiring method according to different scenarios.</p>
<b>Step 2</b>	<p>Inverter communication wiring</p>
<b>Step 3</b>	<p>Meter wiring</p>

**Note!**

Grid-side inflow/outflow current < 80A, meter can be connected directly.

Wiring Table between the AI Link and the Meter.

	AI Link	Meter (CHINT DTSU666)
RS485 A	Pin2 (Meter/485, RS485- A1)	Pin24
RS485 B	Pin1 (Meter/485, RS485- B1)	Pin25

CT meter needs to be purchased separately, if required. The meter's part number is 30-803-00038-00. The CT for this meter is not standard and can be selected according to the customer's actual requirements.

CT Meter wiring Diagram:

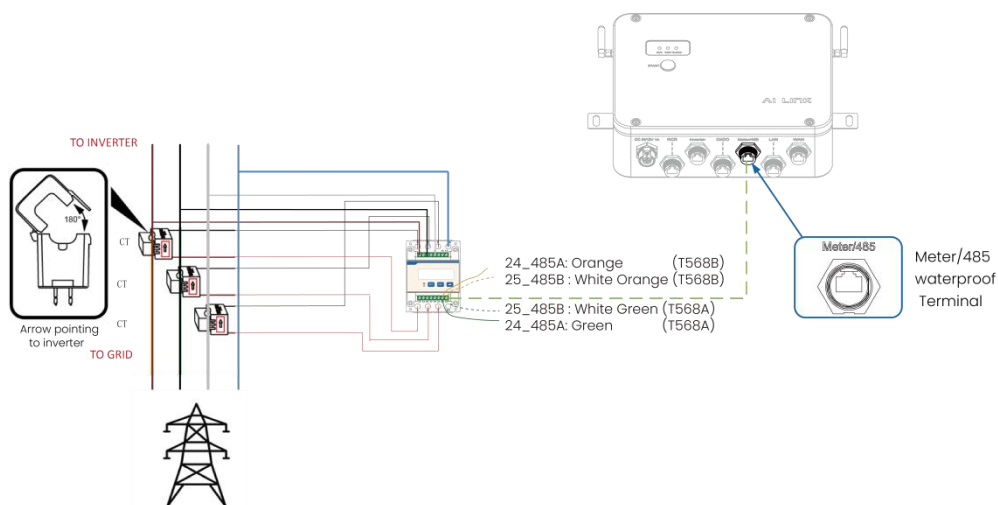

### Note!

Grid-side inflow/outflow current > 80A, use Current Transformer.

### 3) APP Configuration Reference

Please download the FoxCloud2.0 APP from Apple store or Google store.



**Note!**





Configure only AI Link networks, no inverter setup needed.

**Note!**

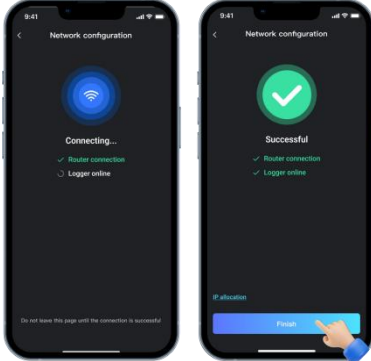
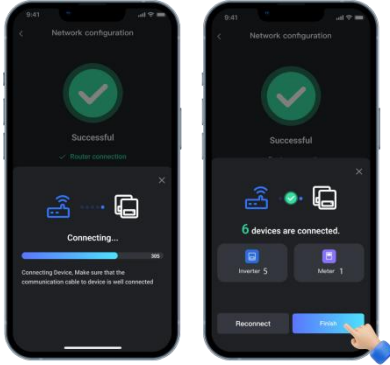
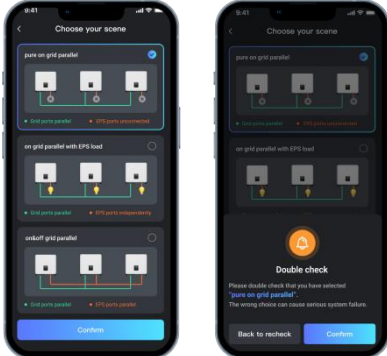
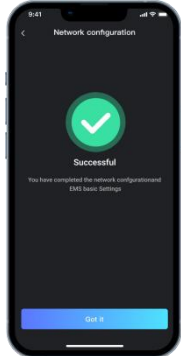
Make sure all communication cables between AI Link and inverters are connected.  
 Make sure all inverters and smart logger are powered on.

Procedures		
<b>Step 1</b>	<p><b>Connect to network</b></p> <p>1-1                      Open APP, then click three point in the top right corner of login page, and choose "WLAN Configuration".</p>	
	<p>1-2                      Keep Bluetooth on and wait for device searching. Then choose the device (EMS_XX XXXXXXXX) and click "Connecting Network".</p>	
	<p>1-3                      Choose SSID of home router and enter password, then click "Next".</p>	

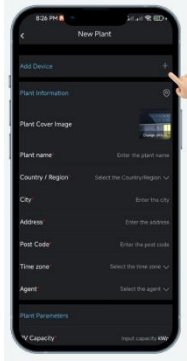
	<p>1-4</p> <p>Wait for about 30s, it will complete the configuration.</p> <p>Then click "Finish".</p>	
<p><b>Step 2</b></p>	<p><b>Connect to device</b></p> <p>Then it will start communicate with devices automatically. Please wait for 30 seconds. Then click "Finish". Please check whether the number of devices is consistent with the actual number. If not, please click "Reconnect" or confirm the cable connection is correct.</p>	
<p><b>Step 3</b></p>	<p><b>Choose your scene</b></p> <p>Select a scene based on the onsite cable connection. Then click "Confirm".</p>	
	<p>It means the network configuration and settings of AI Link are both successful.</p> <p>Then click "Got it", it will turn to login page.</p>	

<p><b>Step 4</b></p>	<p><b>Sign in</b> Enter your username and password, and click “sign in”.</p>	
	<p><b>Create a plant</b> 5-1 Click “Create a plant”.</p>	
<p><b>Step 5</b></p>	<p>5-2 Click “Add Device “</p>	
	<p>5-3 Scan the SN of EMS logger, and click “Confirm”.</p>	

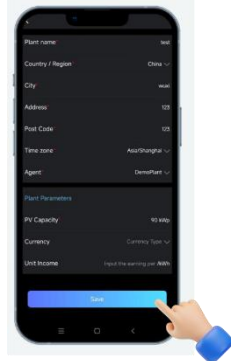
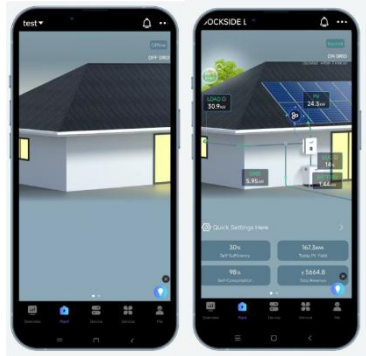
	<p>5-4</p> <p>Enter the basic information, and click "Save".</p> <p>It will turn to homepage.</p>	
<p><b>Step 6</b></p>	<p><b>Wait and refresh</b></p> <p>It may need to wait for 3-5 minutes to upload inverters data, please be patient.</p> <p>You can swipe to refresh this page.</p>	
<p><b>Step 7</b></p>	<p><b>Check device</b></p> <p>Click the rotating ring to go to the parallel page.</p> <p>Check if all devices are shown well.</p>	

# 8 Firmware Upgrading

User can upgrade inverter's firmware via a U-disk.

### Note!

This section is intended to inform users on how to perform software upgrades via a U-disk. Please note that firmware upgrades are only permitted to be conducted by manufacturer-authorized installers. Additionally, during the upgrade process, installers must contact the manufacturer to obtain the upgrade firmware. Sharing of firmware programs is strictly prohibited. Upgrades may only be initiated after receiving explicit authorization from the manufacturer. End-users and other non-authorized personnel are prohibited from performing upgrades.

- Safety check

Please ensure the inverter is steadily powered on.

Inverter must keep the battery on through whole procedure of upgrading. Please prepare a PC and make sure the size of U-disk is under 32G, and the format is fat 16 or fat 32.

- Upgrading steps:

Procedures	
<b>Step 1</b>	<p>Please contact our service support to get the update files, and extract it into your U-disk as follow:</p> <p>update/master/ H3_G2_Smart_Master_Vx.xx.bin            update/slave/ H3_G2_Smart_Slave_Vx.xx.bin            update/manager/ H3_Power_Qube_Manager_Vx.xx.bin</p> <p>Note: Vx.xx is version number.</p> <div style="background-color: yellow; text-align: center; padding: 5px;"><b>⚠ Warning!</b></div> <p>If the inverter has faulted, avoid standing directly in front of it.            Avoid touching any parts of the inverter that may be energized.</p>
<b>Step 2</b>	<p>Unscrew the waterproof lid and insert U-disk into the "USB" port at the bottom of the inverter.</p>

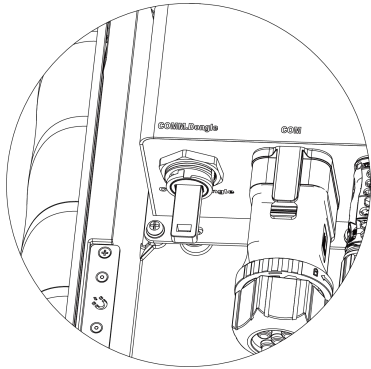
	
<b>Step 3</b>	The LCD will show the selection menu. Then press up and down to select the one that you want to upgrade and press "OK" to confirm to upgrade.
<b>Step 4</b>	After the upgrade is finished, pull out the U-disk. Screw the waterproof lid.

- **local upgrading:**





### USB Upgrade Operation Guide (Apply to Hybrid)

Introduction: The inverter is a high-tech integrated system with a CPU controller, which requires maintenance and upgrade. The upgrade is easy to operate with by end user or installer, upgrade files will be provided by manufacturer, please prepare everything ready before performing this upgrade.

*\*The same procedure is used for Hybrid charger.*

Preparations:

Prepare one USB 2.0 with memory less than 32G (USB 3.0 incompatibility)

 <b>USB 2.0</b>	<b>USB 3.0</b>
★★★★☆ (385 ratings)	★★★★☆ (457 ratings)
	
<b>Released</b> April 2000	November 2008
<b>Speed</b> High Speed or HS, 480 Mbps (Megabits per second)	10 times faster than USB 2.0, Super Speed or SS, 4.8 Gbps (Giga bits per second)
<b>Signaling Method</b> Polling mechanism i.e can either send or receive data (Half duplex)	Asynchronous mechanism i.e. can send and receive data simultaneously (Full duplex)
 <b>USB 2.0</b>	<b>USB 3.0</b>
<b>Power Usage</b> Up to 500 mA	Up to 900 mA. Allows better power efficiency with less power for idle states. Can power more devices from one hub.
<b>Number of wires within the cable</b> 4	9
<b>Standard-A Connectors</b> Grey in color	Blue in color
<b>Standard-B Connectors</b> Smaller in size	Extra space for more wires

2) Install the USB disk on your laptop, open it and create a folder named 'update'

3) Create another three separate subfolders named 'manager' 'master' 'slave' under 'update' folder.

4) Put the upgrade file into corresponding folder as shown below

\* Format of the file name: Model\_Firmware type\_Vx\_xx

File names example:



U:\update\master\Hybrid\_Master\_Vx\_xx

U:\update\slave\Hybrid\_Slave\_Vx\_xx

U:\update\manager\Hybrid\_Manager\_Vx\_xx

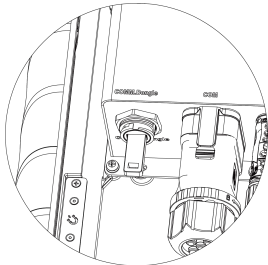

5) Prepare a slotted screwdriver for removing the upgrade port cover.

Procedures	
<b>Step 1</b>	Turn off AC breaker (main circuit breaker) firstly then turn off DC breaker, make sure the inverter is powered off.
<b>Step 2</b>	Remove the upgrade port cover with a screwdriver.
<b>Step 3</b>	<p>Plug in the USB disk.</p> 
<b>Step 4</b>	<p>Only turn on DC breaker (<b>make sure PV voltage is above 120V</b>) wait for 10 seconds, the inverter screen will show as below:</p> 

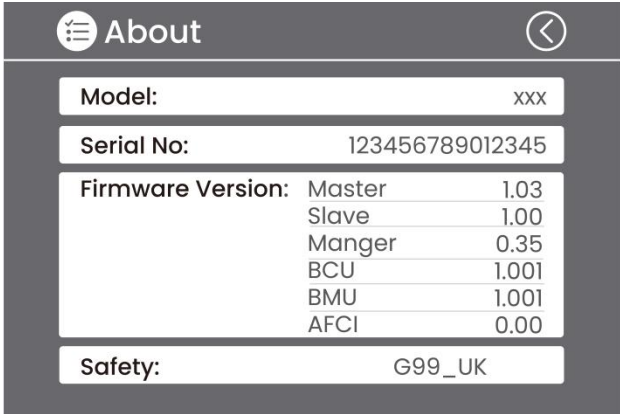
<p><b>Step 5</b></p>	<p>Upon inserting a USB flash drive, the firmware update page will automatically pop up. click on different icons to switch views; the option with a white background indicates selection.</p> 
<p><b>Step 6</b></p>	<p>Remove the USB disk after upgrade completed. Follow the procedure below and click the option to view the version.</p> <p><b>Menu -&gt; About -&gt; Inv Ver</b></p> 
	<p>Turn on AC &amp;DC breaker. If you updated the HMI, long press the "enter" and click "set" to turn on the inverter. Make sure the inverter can enter <b>Normal State</b>.</p>

# 9 Operation

## 9.1 Control Panel

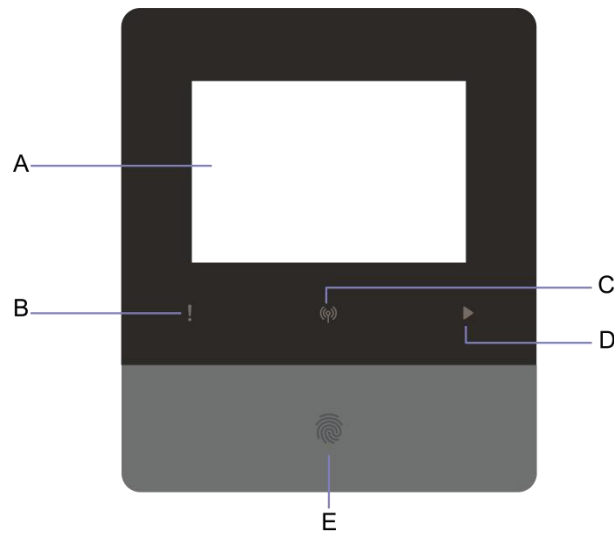

Object	Name	Function
A	LCD screen	Display the information of the inverter.
B	Indicator LED	Red: The inverter is in fault mode.
C		Blue: Light off- No network connection. Blink- connect to the internet. Light on- connection successful.
D		Green: The inverter is in normal state.
E	Function button	<p><b>Touchscreen Wake-up</b> Light press: When the touchscreen is off, the user lightly presses the button. After the finger is released, the system responds and performs the screen wake-up operation.</p> <p><b>Return to Home</b> Double-tap (Screen on): In any menu interface other than the home screen, quickly double-tap the button will trigger the action. (Judgment condition: The time interval between two consecutive valid short presses is not greater than 1 second.)</p> <p><b>Touchscreen System Reset</b> Long press for 10s (Screen on): When the touchscreen experiences abnormal states such as interface freeze or unresponsiveness, the user long-presses the system button for 10 seconds while the screen is on. Upon releasing the finger, a forced reset operation is triggered, and the</p>

		<p>screen displays "Loading".</p> <p><b>Wilan Reset</b></p> <p>Screen on:</p> <p>While the screen is on, the user long-presses for 25 seconds. Upon releasing the finger, a Wilan reset is triggered. The software adds a reset register to implement the factory ATE test reset function. (This function is a safety regulation requirement and is defined as a hidden operation.)</p>
--	--	---

1. Disconnect the AC and Backup vacs.
2. Rotate DC SWITCH to the off state.
3. Turn off the buttons and control switches on the battery.
4. Wait for the screen on top of the machine to go off.
5. Wait for 15 minutes, this is to ensure that the capacitors inside the machine discharge.
6. Use a current clamp to make sure there is no current on the DC line.
7. Using the tool on the DC terminal, press the two snaps on the DC terminal and pull it outward with force at the same time.
8. Make sure there is no PV positive terminal and no voltage above the PV negative terminal, use a multimeter to measure.
9. Also use a multimeter to measure the PV positive and PV negative terminals to the PE line above the voltage no voltage.
10. Use a tool to disconnect the AC terminal and the terminal for communication.

### Operating status LED

This LED is used to indicate if the battery is operating effectively. A green light on this LED means the battery is ON and operating normally. If the battery is operating failure, a red light on this LED means the battery is operating abnormally.

### EQ-S Features:

Interface:

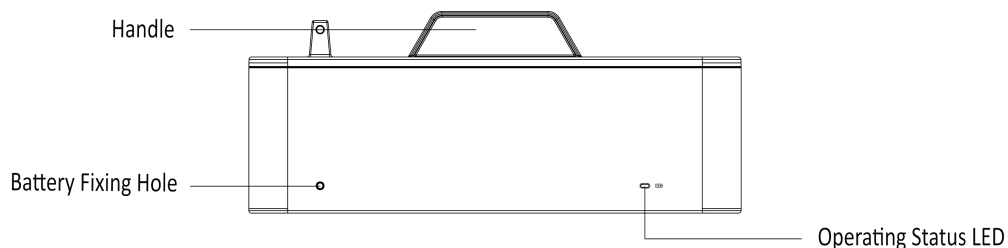

**For EQ-S**

Green LED	Red LED	Batteries Status
On for 0.5s, Off for 0.5s	On for 0.5s, Off for 0.5s	Running in boot
On for 0.1s, Off for 0.1s	On for 0.1s, Off for 0.1s	Upgrading
On for 1s, Off for 1s	Off	Normal Working
Off	On for 1s, Off for 1s	Alarm

**9.2 Function Tree**

- Single machine operation mode

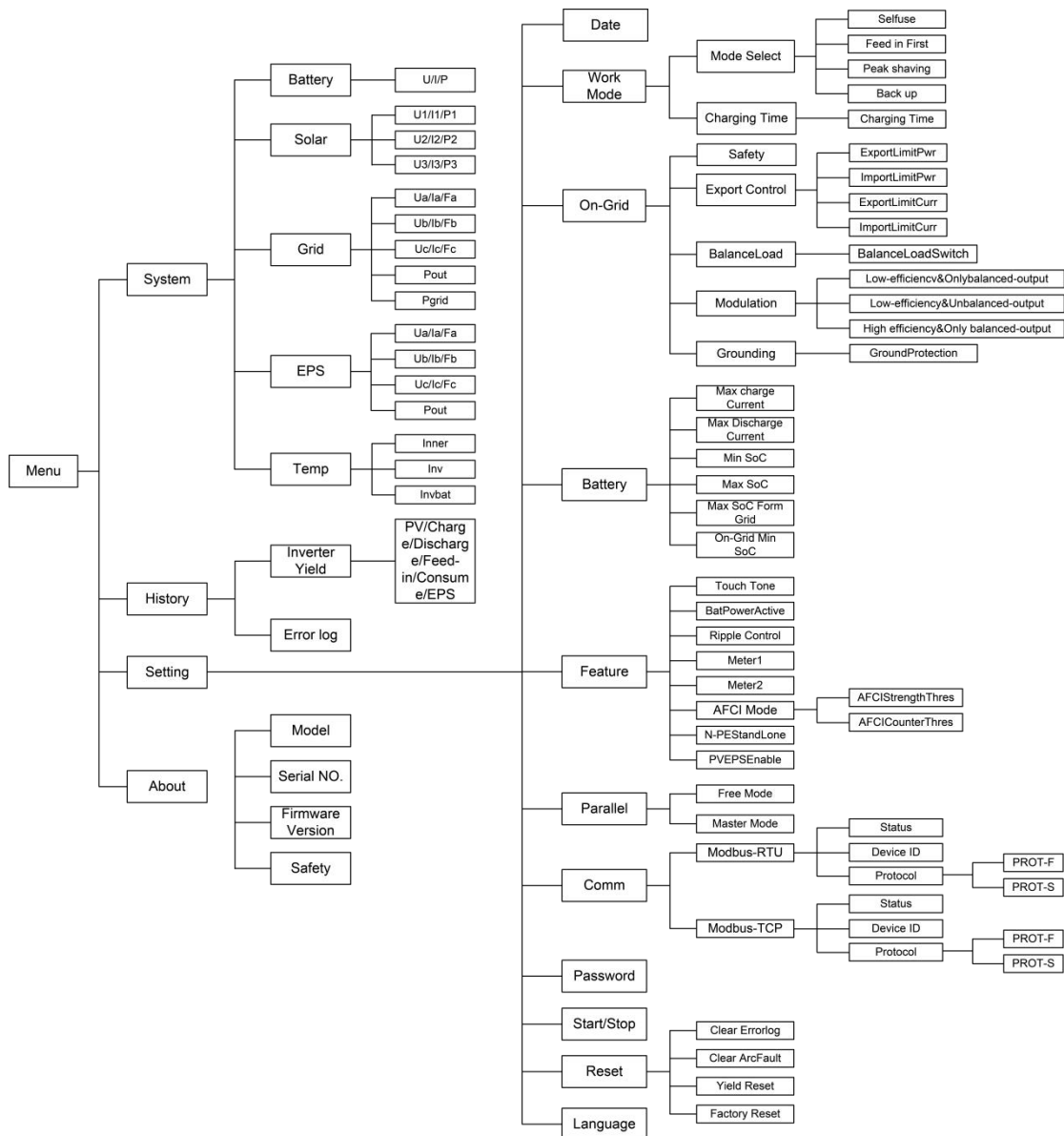

# 10 Maintenance

This section contains information and procedures for solving possible problems with the inverters and provides you with troubleshooting tips to identify and solve most problems that can occur.

## 10.1 Alarm List

Fault Code	Solution
Grid Lost Fault	<p>Grid is lost.</p> <ul style="list-style-type: none"> <li>• System will reconnect if the utility is back to normal.</li> <li>• Or seek help from us, if not go back to normal state.</li> </ul>
Grid Volt Fault	<p>Grid voltage out of range.</p> <ul style="list-style-type: none"> <li>• System will reconnect if the utility is back to normal.</li> <li>• Or seek help from us, if not go back to normal state.</li> </ul>
Grid Freq Fault	<p>Grid frequency out of range.</p> <ul style="list-style-type: none"> <li>• System will reconnect if the utility is back to normal.</li> <li>• Or seek help from us, if not go back to normal state.</li> </ul>
PLL_OverTime	<p>Three-phase system access single-phase AC.</p> <ul style="list-style-type: none"> <li>• System will reconnect if the utility is back to normal.</li> <li>• Or seek help from us, if not go back to normal state.</li> </ul>
10min Volt Fault	<p>The grid voltage is out of range for the last 10 Minutes.</p> <ul style="list-style-type: none"> <li>• System will reconnect if the utility is back to normal.</li> <li>• Or seek help from us, if not go back to normal state.</li> </ul>
SW Inv Cur Fault	<p>Output current high detected by software.</p> <p>To upgrade to the latest software, at least ensure that the master is upgraded to 1.69 or above.</p> <ul style="list-style-type: none"> <li>• Disconnect PV, grid and battery, then reconnect.</li> <li>• Or seek help from us, if not go back to normal state.</li> </ul>
DCI Fault	<p>DC component is out of limit in output current.</p> <ul style="list-style-type: none"> <li>• Disconnect PV, grid and battery, then reconnect.</li> <li>• Or seek help from us, if not go back to normal state.</li> </ul>
HW Inv Cur Fault	<p>Output current high detected by hardware.</p> <ul style="list-style-type: none"> <li>• Disconnect PV, grid and battery, then reconnect.</li> <li>• Or seek help from us, if not go back to normal state.</li> </ul>
SW Bus Vol Fault	<p>Bus voltage out of range detected by software.</p> <p>Please check whether the N line is connected to the GRID port of the inverter.</p> <p>To upgrade to the latest software, at least ensure that the master is upgraded to 1.69 or above.</p> <ul style="list-style-type: none"> <li>• Disconnect PV, grid and battery, then reconnect.</li> <li>• Or seek help from us, if not go back to normal state.</li> </ul>

Bat Volt Fault	<p>Battery voltage fault.</p> <ul style="list-style-type: none"> <li>• Check if the battery input voltage is within the normal range.</li> <li>• Or seek help from us.</li> </ul>
SW Bat Cur Fault	<p>Battery current high detected by software.</p> <ul style="list-style-type: none"> <li>• Disconnect PV, grid and battery, then reconnect.</li> <li>• Or seek help from us, if not go back to normal state.</li> </ul>
Iso Fault	<p>The isolation is failed.</p> <ul style="list-style-type: none"> <li>• Please check if the insulation of electric wires is damaged.</li> <li>• Wait for a while to check if back to normal.</li> <li>• Or seek for help from us.</li> </ul>
Res Cur Fault	<p>The residual current is high.</p> <ul style="list-style-type: none"> <li>• Please check if the insulation of electric wires is damaged.</li> <li>• Wait for a while to check if back to normal.</li> <li>• Or seek for help from us.</li> </ul>
Pv Volt Fault	<p>PV voltage out of range.</p> <ul style="list-style-type: none"> <li>• Please check the output voltage of PV panels.</li> <li>• Or seek for help from us.</li> </ul>
SW Pv Cur Fault	<p>PV input current high detected by software.</p> <ul style="list-style-type: none"> <li>• Disconnect PV, grid and battery, then reconnect.</li> <li>• Or seek help from us, if not go back to normal state.</li> </ul>
Temp Fault	<p>The inverter temperature is high.</p> <ul style="list-style-type: none"> <li>• Please check if the environment temperature.</li> <li>• Wait for a while to check if back to normal.</li> <li>• Or seek for help from us.</li> </ul>
Ground Fault	<p>The ground connection is failed.</p> <ul style="list-style-type: none"> <li>• Check the voltage of neutral and PE.</li> <li>• Check AC wiring.</li> <li>• Disconnect PV, grid and battery, then reconnect.</li> <li>• Or seek help from us, if not go back to normal state.</li> </ul>
Over Load Fault	<p>Over load in on grid mode.</p> <ul style="list-style-type: none"> <li>• Please check if the load power exceeds the limit.</li> <li>• Or seek for help from us.</li> </ul>
Backup Over Load	<p>Over load in off grid mode.</p> <ul style="list-style-type: none"> <li>• Please check if the Backup load power exceeds the limit.</li> <li>• Or seek for help from us.</li> </ul>
Bat Power Low	<p>The battery power is low.</p> <ul style="list-style-type: none"> <li>• Wait the battery to be recharged.</li> <li>• Or seek for help from us.</li> </ul>
HW Bus Vol Fault	<p>Bus voltage out of range detected by hardware.</p> <ul style="list-style-type: none"> <li>• Disconnect PV, grid and battery, then reconnect.</li> <li>• Or seek help from us, if not go back to normal state.</li> </ul>

HW Pv Cur Fault	<p>PV input current high detected by hardware.</p> <p>Check whether PV positive and negative are connected.</p> <ul style="list-style-type: none"> <li>• Disconnect PV, grid and battery, then reconnect.</li> <li>• Or seek help from us, if not go back to normal state.</li> </ul>
HW Bat Cur Fault	<p>Battery current high detected by hardware.</p> <ul style="list-style-type: none"> <li>• Disconnect PV, grid and battery, then reconnect.</li> <li>• Or seek help from us, if not go back to normal state.</li> </ul>
SCI Fault	<p>The communication between master and manager is fail.</p> <ul style="list-style-type: none"> <li>• Disconnect PV, grid and battery, then reconnect.</li> <li>• Or seek help from us, if not go back to normal state.</li> </ul>
MDSP SPI Fault	<p>The communication between master and slave is fail.</p> <ul style="list-style-type: none"> <li>• Disconnect PV, grid and battery, then reconnect.</li> <li>• Or seek help from us, if not go back to normal state.</li> </ul>
MDSP Smpl Fault	<p>The master sample detection circuit is failed.</p> <ul style="list-style-type: none"> <li>• Disconnect PV, grid and battery, then reconnect.</li> <li>• Or seek help from us, if not go back to normal state.</li> </ul>
Res Cur HW Fault	<p>Residual current detection device is failed.</p> <ul style="list-style-type: none"> <li>• Disconnect PV, grid and battery, then reconnect.</li> <li>• Or seek help from us, if not go back to normal state.</li> </ul>
Inv EEPROM Fault	<p>The inverter eeprom is fault.</p> <ul style="list-style-type: none"> <li>• Disconnect PV, grid and battery, then reconnect.</li> <li>• Or seek help from us, if not go back to normal state.</li> </ul>
PvCon Dir Fault	<p>The PV connection is reversed.</p> <ul style="list-style-type: none"> <li>• Check if the positive pole and negative pole of PV are correctly connected.</li> <li>• Or seek help from us.</li> </ul>
Bat Relay Open	<p>The battery relay keeps open.</p> <ul style="list-style-type: none"> <li>• Disconnect PV, grid and battery, then reconnect.</li> <li>• Or seek help from us, if not go back to normal state.</li> </ul>
Bat Relay Short Circuit	<p>The battery relay keeps close.</p> <ul style="list-style-type: none"> <li>• Disconnect PV, grid and battery, then reconnect.</li> <li>• Or seek help from us, if not go back to normal state.</li> </ul>
Bat Buck Fault	<p>The battery buck circuit mosfet is fail.</p> <ul style="list-style-type: none"> <li>• Disconnect PV, grid and battery, then reconnect.</li> <li>• Or seek help from us, if not go back to normal state.</li> </ul>
Bat Boost Fault	<p>The battery boost circuit mosfet is fail or The relay on the battery side of the inverter is not closed.</p> <p>To upgrade to the latest software, at least ensure that the master is upgraded to 1.69 or above.</p> <ul style="list-style-type: none"> <li>• Disconnect PV, grid and battery, then reconnect.</li> <li>• Or seek help from us, if not go back to normal state.</li> </ul>
Backup Relay Fault	<p>The Backup relay is failed.</p> <ul style="list-style-type: none"> <li>• Disconnect PV, grid and battery, then reconnect.</li> <li>• Or seek help from us, if not go back to normal state.</li> </ul>

BatCon Dir Fault	<p>The battery connection is reversed.</p> <ul style="list-style-type: none"> <li>• Check if the positive pole and negative pole of battery are correctly connected.</li> <li>• Or seek help from us.</li> </ul>
Grid Relay Fault	<p>The grid relay keeps open or close.</p> <ul style="list-style-type: none"> <li>• Disconnect PV, grid and battery, then reconnect.</li> <li>• Or seek help from us, if not go back to normal state.</li> </ul>
RDSP SPI Fault	<p>The communication between master and slave is fail.</p> <ul style="list-style-type: none"> <li>• Disconnect PV, grid and battery, then reconnect.</li> <li>• Or seek help from us, if not go back to normal state.</li> </ul>
RDSP Smpl Fault	<p>The slave sample detection circuit is failed.</p> <ul style="list-style-type: none"> <li>• Disconnect PV, grid and battery, then reconnect.</li> <li>• Or seek help from us, if not go back to normal state.</li> </ul>
ARM EEPROM Fault	<p>The manager eeprom is fault.</p> <ul style="list-style-type: none"> <li>• Disconnect PV, grid and battery, then reconnect.</li> <li>• Or seek help from us, if not go back to normal state.</li> </ul>
Meter Lost Fault	<p>The communication between meter and inverter is interrupted.</p> <ul style="list-style-type: none"> <li>• Check if the communication cable between meter and inverter is correctly and well connected.</li> </ul>
BMS Lost	<p>The communication between BMS and inverter is interrupted.</p> <ul style="list-style-type: none"> <li>• Check if the communication cable between BMS and inverter is correctly and well connected.</li> </ul>
Bms Ext Fault	<p>The communication between BMS and inverter is interrupted.</p> <ul style="list-style-type: none"> <li>• Check if the communication cable between BMS and inverter is correctly and well connected.</li> </ul>
Bms Int Fault	<p>DIP switch at the wrong position; The communication between battery packs is interrupted.</p> <ul style="list-style-type: none"> <li>• Move the DIP switch to the correct position;</li> <li>• Check if the communication cable between battery packs is correctly and well connected.</li> </ul>
Bms Volt High	<p>Battery over voltage.</p> <ul style="list-style-type: none"> <li>• Please contact battery supplier.</li> </ul>
Bms Volt Low	<p>Battery under voltage.</p> <ul style="list-style-type: none"> <li>• Please contact battery supplier.</li> </ul>
Bms ChgCur High	<p>Battery charge over current.</p> <ul style="list-style-type: none"> <li>• Please contact battery supplier.</li> </ul>
Bms DchgCur High	<p>Battery discharge over current.</p> <ul style="list-style-type: none"> <li>• Please contact battery supplier.</li> </ul>

Bms Temp High	Battery over temperature. • Please contact battery supplier.
Bms Temp Low	Battery under temperature. • Please contact battery supplier.
BmsCellImbalance	The capacities of cells are different. • Please contact battery supplier.
Bms HW Protect	Battery hardware under protection. • Please contact battery supplier.
BmsCircuit Fault	Bms hardware circuit fault. • Please contact battery supplier.
Bms Insul Fault	Battery insulation fault. • Please contact battery supplier.
BmsVoltsSen Fault	Battery voltage sensor fault. • Please contact battery supplier.
BmsTempSen Fault	Battery temperature sensor fault. • Please contact battery supplier.
BmsCurSen Fault	Battery current sensor fault. • Please contact battery supplier.
Bms Relay Fault	Battery relay fault. • Please contact battery supplier.
Bms Type Unmatch	The capacity of battery packs is different. • Please contact battery supplier.
Bms Ver Unmatch	The software between slaves are different. • Please contact battery supplier.
Bms Mfg Unmatch	The cell manufacture is different. • Please contact battery supplier.
Bms SwHw Unmatch	The slave software and hardware are not match. • Please contact battery supplier.
Bms M&S Unmatch	The software between Master and Slave are not match. • Please contact battery supplier.
Bms ChgReq NoAck	No action for charging request. • Please contact battery supplier.

## 10.2 Troubleshooting and Routine Maintenance

- Troubleshooting
  - a. Please check the fault message on the System Control Panel or the fault code on the inverter information panel. If a message is displayed, record it before doing anything further.
  - b. Attempt the solution indicated in table above.
  - c. If your inverter information panel is not displaying a fault light, check the following to make sure that the current state of the installation allows for proper operation of the unit:
    - (1) Is the inverter located in a clean, dry, adequately ventilated place?
    - (2) Have the DC input breakers opened?
    - (3) Are the cables adequately sized?
    - (4) Are the input and output connections and wiring in good condition?
    - (5) Are the configurations settings correct for your particular installation?
    - (6) Are the display panel and the communications cable properly connected and undamaged?

Contact Customer Service for further assistance. Please be prepared to describe details of your system installation and provide the model and serial number of the unit.

- Maintenance checking list

During the process of using the inverter, the responsible person shall examine and maintain the machine regularly. The required actions are as follows.

- Check that if the cooling fins at the rear of the inverters are collecting dust/dirt, and the machine should be cleaned when necessary. This work should be conducted periodically.
- Check that if the indicators of the inverter are in normal state, check if the display of the inverter is normal. These checks should be performed at least every 12 months.
- Check if the input and output wires are damaged or aged. This check should be performed at least every 12 months.
- Get the inverter panels cleaned and their security checked at least every 6 months.

Note: Only qualified individuals may perform the following works.

# 11 Inverter Storage and Disposal

## 11.1 Disassembling the Inverter

- Disconnect the inverter from the DC input and AC output. Wait for 15 minutes to ensure the inverter is completely powered down.
- Disconnect communication cables and any optional monitoring modules. Remove the inverter from the wall mounting bracket.

If possible, use the original packaging to repack the inverter. If the original packaging is unavailable, an equivalent box meeting the following requirements may be used:

- Capable of bearing a weight of 40 kg.
- Includes handles.
- Can be fully enclosed

## 11.2 Storing the Inverter

If the inverter is not put into operation immediately, it must be stored under specific environmental conditions.

- Regularly inspect the storage condition of the inverter. Check for moisture, mold, or signs of pest/rodent infestation. Replace packaging materials promptly if necessary.
- The equipment must be stored in a dry, well-ventilated area with a relatively stable temperature, consistently maintained between  $-40^{\circ}\text{C}$  ~  $+70^{\circ}\text{C}$ , and a relative humidity range of 0% to 100%. Avoid direct sunlight and keep a distance of  $\geq 2\text{m}$  from heat sources.
- Avoid locations subject to water splashing, rain, dampness, high temperatures, or outdoor exposure. If the floor is damp, place the packaging box on a shelf or elevated platform to avoid direct contact with the ground and minimize moisture risk.
- The storage area must be free of harmful gases, flammable, explosive materials, and corrosive chemicals.
- For long-term storage, the equipment must be covered or appropriate measures taken to protect it from contamination and environmental impact.
- Avoid mechanical shock, heavy pressure, strong electric fields, and strong magnetic fields.
- When stacking multiple inverters, do not exceed 4 cartons in height.
- Products stored under the above conditions for more than 12 months must undergo capacity verification tests and re-inspection before they can be used.

Note: Please adhere to the storage requirements. Product damage caused by failure to meet these conditions is not covered under warranty.

## 11.3 Transporting the Inverter

- Ensure the product is securely packaged before vehicle transport. Use enclosed containers for long-distance transportation.
- It is strictly prohibited to transport this product together with equipment or items that could potentially affect or damage it.

## 11.4 Decommissioning/Scrapping the Inverter

- Certain components of the inverter may cause environmental pollution. When disposing of the inverter or its related components, ensure compliance with local waste disposal regulations.

# 12 Battery Troubleshooting and Maintenance

## 12.1 Maintenance

- Regularly check whether the service environment of the battery meets the requirements, and the installation position should be far away from the heat source.
- The battery module should be stored in an environment with a temperature range between -20°C- +55°C, and charged regularly according to the table below with no more than 0.5 C(A C-rate is a measure of the rate at which a battery is discharged relative to its maximum capacity.) to the SOC of 50% after a long time of storage.

Storage environment temperature	Relative humidity of the storage environment	Storage time	SOC
Below -20°C	/	Not allowed	/
-20~0°C	10%~90%	≤ 1 months	20%≤SOC≤50%
0~35°C	10%~90%	≤ 6 months	20%≤SOC≤50%
35~55°C	10%~90%	≤ 1 months	20%≤SOC≤50%
Above 55°C	/	Not allowed	/

Note: If the battery is stored over one year, 5%- 8% of the capacity may lose irreversibly.

- Regularly check whether the battery and its supporting terminals, connecting cables and indicator lights are normal.

### Expanded capacity requirement

If a battery is replaced or added for capacity expansion, each battery's SOC should be consistent. The max. SOC difference should be between ±5%.

If users want to increase their battery system capacity, please ensure that the SOC of the existing system capacity is about 50%. The manufacturer date of the new battery shall not exceed 12 months; in case of exceeding 12 months. please charge the new battery to around 50%.

## 12.2 Storage with Low SOC

After the product is powered off, static power consumption and self-discharge loss may occur in internal modules. Therefore, charge batteries in a timely manner and do not store the product in low SOC. Otherwise, the product may be damaged due to overdischarge, and battery modules need to be replaced.

Storage in low SOC may occur in the following scenarios:

- The DC SWITCH on the power control module is OFF.

- The power cables or signal cables are not connected.
- The batteries cannot be charged due to a system fault after discharge.
- The batteries cannot be charged due to incorrect configurations in the system.
- The batteries cannot be charged due to no PV input and long-term mains failure.

Regardless of scenarios, the batteries must be charged within the longest interval corresponding to the SOC when the batteries are powered off. If the batteries are not charged within the specified interval, they may be damaged due to overdischarge.

Storage environment temperature	Power-Off SOC Before Storage	Maximum Charge Interval
0~35°C	0% ≤ SOC < 5%	7 days

Note: When the battery SOC decreases to 0%, charge the batteries within seven days. Permanent battery faults caused by delayed charge due to customer reasons are beyond the warranty scope.

## 12.3 Troubleshooting

When the red / green LED on the panel is flashing or normally on, it does not mean that the battery is abnormal, it may be just an alarm or protection. In general, the alarm indication is normal without manual intervention. When the alarm triggering state is removed, battery will automatically return to normal use.

### Problem determination based on the following points:

- Whether the battery system can be communicated with inverter;
- Whether the battery can be output voltage or not.

### Preliminary determination steps

In the case that the DC switch is turned on and powered, and that the waterproof cover is properly installed, if the battery system still fails to work and the LED flashes or does not light up, please contact the local distributor.

- In the case that the subordinate battery displays normally while the battery system cannot charge or discharge and the inverter display does not show SOC or battery voltage, please contact the local distributor.
- After the battery system is powered on, if you can see the alarm information on the LED and inverter display screen at the same time, please contact the local distributor.

# 13 Appendix

## 13.1 Quality Guarantee

FOXESS Co., Ltd. (hereinafter referred to as "the Company") will, for products found to be faulty during the warranty period, repair the product free of charge or replace it with a new one.

### Supporting Documentation Required

When requesting warranty service, the customer must present the original purchase invoice indicating the date of purchase. Furthermore, the product's trademark must be clearly visible. The Company reserves the right to decline warranty coverage if these conditions are not met.

### Relevant Conditions

- Non-conforming products replaced under warranty shall be disposed of by the Company.
- The customer must allow the Company a reasonable period of time to complete repairs on faulty equipment.

### Warranty Exclusions

The Company reserves the right to decline warranty coverage under the following circumstances:

- The entire machine or specific components have exceeded the free warranty period.
- Damage incurred during transportation.
- Faults resulting from incorrect installation, modification, or use.
- Operation in environments that exceed the limits specified as harsh in this manual.
- Malfunctions or damage caused by installation, repair, alteration, or disassembly performed by service organizations or personnel not authorized by the Company.
- Use or installation outside the scope defined in the relevant international standards.
- Damage caused by abnormal natural disasters.
- Damage resulting from storage conditions that do not meet the requirements stated in the product documentation.
- Any losses arising from failure to adhere to the safety precautions outlined in this manual.

If a product failure is caused by any of the above circumstances and the customer still requests repair services, the Company's authorized service organization may, upon assessment, provide repair services subject to a charge.

### Other Provisions

The Company reserves the right to change product dimensions and parameters based on its latest documentation without prior notice.

## 13.2 Contact Us

If you have any questions about the product, please contact us:

- Fox ESS Headquarters: No.939, Jinhai Third Road, New Airport Industry Area, Longwan District, Wenzhou, Zhejiang, China.
- Wuxi R&D Center: No. 97 Huaqing Avenue, Wuxi Economic Development Zone (Intersection of Huaqing Avenue and Huayun Road)
- Wuhan R&D Center: 6th Floor, Block A, Tower T4, CHINA PROCUREMENT CENTER, No.789 Gaoxin Avenue, East Lake New Technology Development Zone, Wuhan City, Hubei Province, P.R. China
- Shanghai R&D Center: No.1255, Jinhai Road, Pudong New Area, Shanghai, China
- After-Sales Service Hotline: 400 1888 900
- Contact Telephone (Wenzhou): 0577-88159999
- Contact Telephone (Wuxi): 0510-68092998
- Contact Us: [info@fox-esscom](mailto:info@fox-esscom)
- Contact Us (EV Charger): [ev@fox-esscom](mailto:ev@fox-esscom)
- After-Sales Service: [service@fox-esscom](mailto:service@fox-esscom)