

User Manual



CQ7 Series

To prevent damage to the product caused by improper use, please carefully read this manual before operation.

Copyright © FOXESS CO., Ltd. All rights reserved.

No part of this document may be reproduced, copied, or distributed in any form or by any means without prior written authorization from the company.

Trademarks



and other Fox ESS trademarks are the property of FOXESS CO., Ltd.

All other trademarks or registered trademarks mentioned in this document belong to their respective owners.

Software License

Commercial use of any part or all of the firmware or software developed by the company is strictly prohibited.

Reverse engineering, decompilation, or any other actions that destroy the original design of the company's software are prohibited.

This document is intended as a usage guide only. All statements, information, and recommendations herein do not constitute any warranty, express or implied.

Due to product version updates or other reasons, the content of this document may be updated periodically. Please download the latest version from the official website if needed.

FOXESS CO., Ltd

Add:

No.939, Jinhai Third Road, New Airport Industry Area, Longwan District, Wenzhou, Zhejiang, China

Tel: 0510- 68092998

Postcode: 325024

WWW.FOX-ESS.COM

Version V1.0.0

Date 2026-04

Content

1 Notes on This Manual	2
1.1 Scope of Validity	2
1.2 Target Group	2
1.3 Symbols Used	2
2 Safety Precautions	5
2.1 Personnel Safety	5
2.2 Handling	5
2.3 Installation	6
2.4 Mounting	6
3 Response to Emergency Situations	8
4 Fire Protection Function	9
4.1 Fire Extinguishing Mechanism	9
4.2 Technical Specifications	10
5 Warm up Function	11
6 Product Introduction	13
6.1 CQ7-50-Lx, (x=2~14) Specifications	13
6.2 CQ7-50-Lx (w), (x=2~14) Specifications	17
6.3 CQ7-Lx, (x=2~14) Specifications	21
6.4 CQ7-Lx (w), (x=2~14) Specifications	25
7 Product Features	29
7.1 Battery System Features	29
8 Installation	31
8.1 Items in the package	31
8.2 Clearance	32
8.3 Tools	33

8.4 Installation Steps	33
8.5 Wiring Steps	37
8.6 System Operation	40
8.7 Disassembly Steps	41
9 Commissioning	43
9.1 Monitoring Methods	43
10 Exclusion	47
11 Troubleshooting and Maintenance	48
11.1 Maintenance	48
11.2 Storage with Low SOC	48
11.3 Troubleshooting	49
11.4 Low-Temperature Battery Reserve	49
12 Appendix	50
12.1 Quality Guarantee	50
12.2 Contact Us	51

1 Notes on This Manual

The document describes the installation, commissioning, maintenance and troubleshooting of the following high voltage battery listed below.

CQ7 Series

The battery chemistry of these products is Lithium Iron Phosphate. This manual is designed for qualified personnel only. The tasks described in this document should be performed by authorized and qualified technicians only.

After Installation the Installer must explain the user manual to the end user.

1.1 Scope of Validity

This manual describes the assembly, installation, commissioning, maintenance and troubleshooting of the following model(s) of products:

CQ7-50-Lx,(x=2/3/4/5/6/7/18/19/110/11/12/13/14)

CQ7-50-Lx (w),(x=2/3/4/5/6/7/18/19/110/11/12/13/14)

CQ7-Lx,(x=2/3/4/5/6/7/18/19/110/11/12/13/14)

CQ7-Lx (w),(x=2/3/4/5/6/7/18/19/110/11/12/13/14)

Please keep this manual where it will be accessible at all times.

1.2 Target Group

This manual is intended for use by qualified electricians only. All procedures described herein shall be performed by trained and experienced electrical personnel in compliance with basic electrical safety requirements.

1.3 Symbols Used

The following symbols are used in the manual to highlight information in order to ensure the safety of the user's person and property when using the product, and to use the product more efficiently and optimally. The following symbols may appear in this manual, and the meanings they represent are listed below:

Danger!

"Danger" indicates a hazardous situation which, if not avoided, will result in death or serious injury.

Warning!

“Warning” indicates a hazardous situation which, if not avoided, could result in minor or moderate injury.

Note!

“Note” provides important tips and guidance.

Symbols	Explanation
	CE mark. The inverter complies with the relevant EU directives.
	The inverter meets the requirements of the UK product safety certification.
	Danger of high voltages. Danger to life due to high voltages in the inverter!
	Do not place nor install near flammable or explosive materials.
	Install the product out of reach of children.
	Prohibit the use of water to extinguish fires.
	Prohibition of private maintenance.
	Prohibit Connector Reversal.



Read the manual before performing any operations on the inverter.



Do not dispose of the product with household wastes.



Disconnect the equipment before carrying out maintenance or repair.



Observe precautions for handling electrostatic discharge sensitive devices.



PE conductor terminal.



Caution, risk of electric shock, energy storage timed discharge ($< 1S$).

2 Safety Precautions

2.1 Personnel Safety

Any work on the batteries should be handled by purchaser approved installer and hence it is understood that the purchaser approved installer should familiarize themselves with the contents of this manual before any maintenance or installation is carried out on the system.

Danger!

Operating Requirements

- ▶ High voltage exists inside the equipment. Unauthorized removal of necessary protective measures, improper use, and improper installation and operation may cause serious safety hazards, shock hazards, or equipment damage, and the resulting damage to the equipment is not covered by the warranty.
- ▶ Do not energize the equipment without completing the installation or without professional confirmation, and strictly prohibit operation with electricity.

Warning!

Operating Requirements

- ▶ Always use special insulated tools for wiring operations. Direct contact or contact with other conductors or indirect contact with the power supply equipment through wet objects is prohibited.
- ▶ During operation of the equipment, the enclosure temperature is high and there is a risk of burns. Before touching any part of the inverter, make sure that the equipment and its surfaces are at a contact-safe temperature and voltage before proceeding.

Note!

Personnel requirements

- ▶ All operations, including transportation, installation, start-up and maintenance, must be performed by qualified and trained personnel.

2.2 Handling

- Do not expose battery to open flame.
- Store in a cool and dry place with ample ventilation.
- Do not store the product near water sources.
- Store the product on a flat surface.
- Recommend to store the product out of reach of children and animals.
- Do not damage the unit by dropping, deforming, impacting, cutting or penetrating with a sharp object. It may cause leakage of electrolyte or fire.
- Do not touch any liquid spilled from the product. There is a risk of electric shock or damage to skin.
- Always handle the battery wearing the insulated gloves.
- Do not step on the product or place any foreign objects on it. This can result in damage.

- Do not charge or discharge damaged battery.

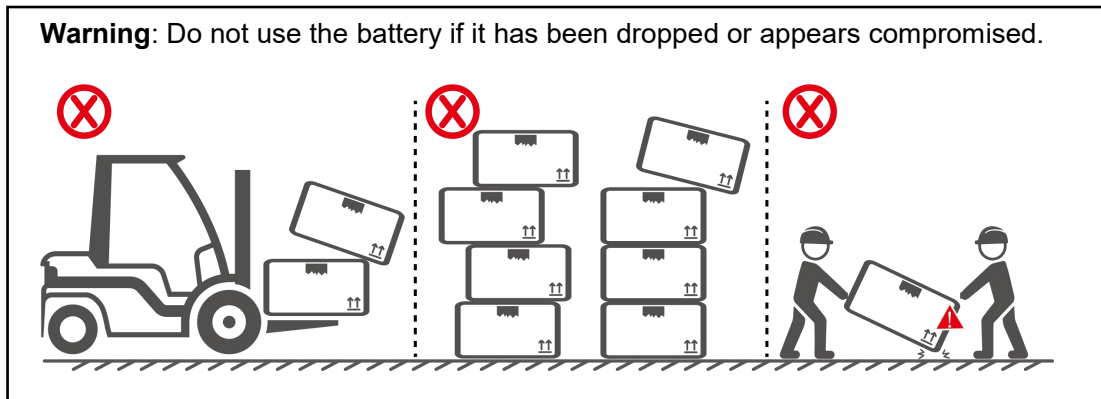

2.3 Installation

- Do not connect the battery directly to inverter conductors or PV conductors. This will damage the battery and may result in explosion.
- After unpacking, please check the product for damages and missing parts.
- Make sure that the inverter and battery is completely turned off before commencing installation.
- Do not interchange the positive and negative terminals of the battery.
- Ensure that there is no short circuit of the terminals or with any external device.
- Do not exceed the battery voltage rating of the inverter.
- Do not connect the battery to any incompatible inverter.
- Do not connect different battery types together.
- Please ensure that all the batteries are grounded properly.
- Do not open the battery to repair or disassemble. Only Fox ESS is allowed to carry out any such repairs.
- In case of fire, use only dry powder fire extinguisher. Liquid extinguishers should not be used.
- Please refrain from installing the battery near any water source to prevent accidental submersion.
- Recommend to install the battery away from children or pets.
- Do not use battery in high static environment where the protection device might be damaged.
- Do not install with other batteries or cells.
- Please ensure on installation site that the deviation of voltages between new batteries and every single present battery is less than 0.5V.
- Recommend to check the new batteries mounted on-site comply to the warranty scope or have ever been re-charged within 5 months; on top of that, please make sure the SOC of present battery system onsite is $50\% \pm 5\%$.

2.4 Mounting

Make sure the installation site meets the following conditions.

- Ensure the installation area is protected from direct sunlight, rain, and snow accumulation, a shelter(e.g., rain canopy)is recommended.
- Keep the installation area away from high-temperature sources, flammable or explosive materials and other potential explosion hazards such as gas valves, LPG cylinders, heat pumps, firewood stacks, etc.
- The installation area must be completely waterproof, with a hard, level floor, and the

wall should not have noticeable inclined angle.

- Maintain low and stable humidity with good ventilation; dust and dirt within the installation area must be minimized.
- Position the installation area away from television antennas or antenna cables to avoid lightning strikes and electromagnetic interference.
- Avoid the presence of flammable debris around the battery, such as cotton, fabric, haystacks, etc. which may be ignited by sparks and then lead the fire source to the battery, thus causing the battery to burn.
- Avoid the presence of hot or flammable objects around the battery, such as hydraulic bottles natural gas, oxygen, etc.), heat pumps and so on.

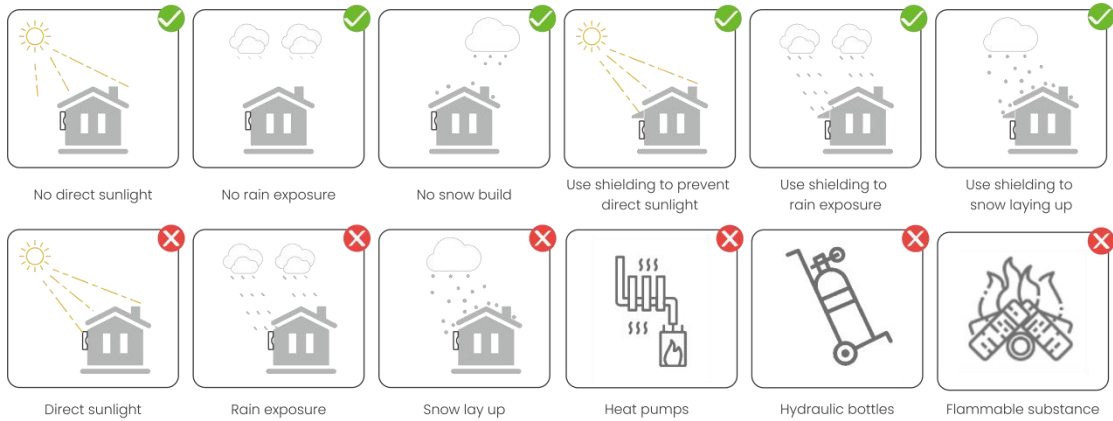

3 Response to Emergency Situations

The batteries comprise of multiple batteries connected in series. It is designed to prevent hazards or failures. However, Fox ESS cannot guarantee their absolute safety.

Under exposure to the internal materials of the battery the following recommendations should be carried out by the user.

- If there has been inhalation, please leave the contaminated area immediately and seek medical attention.
- If there has been contact with eyes, rinse the eyes with running water for 15 minutes and seek medical attention immediately.
- If there has been contact with the skin, wash the contacted area with soap thoroughly and seek medical attention immediately.
- If there has been ingestion, induce vomiting and seek medical attention.

Fire Situation

In situations where the battery is on fire, if it is safe to do so, disconnect the battery pack by turn off the circuit breaker to shut off the power to the system. Use FM-200 or CO₂ fire extinguisher for the battery and an ABC fire extinguisher for the other parts of the system.

Under any fire situation, please evacuate the people from the building immediately before trying to extinguish it.

Water Situation

The battery modules are not water resistant. Hence care should be taken not to get it wet. If you find the battery completely or partially submerged in water do not try to open. Contact an authorized personnel or Fox ESS for further instructions.

4 Fire Protection Function

Despite the extremely stable chemical properties of lithium iron phosphate batteries and the multiple protections, each battery unit is equipped with a fire protection module to further ensure the safety and reliability of Fox ESS batteries. This innovative module utilizes a new type of aerosol fire extinguishing device with features such as pressure-free storage, no maintenance required, high extinguishing efficiency, non-toxic and harmless characteristics.

4.1 Fire Extinguishing Mechanism

The fire extinguishing mechanisms of common agents mainly include isolation, smothering, cooling, and chemical suppression, with different agents exhibiting varying mechanisms. The fire extinguishing mechanism of thermal aerosols involves two main mechanisms: the cooling effect from endothermic decomposition and the chemical suppression effects in both gas and solid phases, which work synergistically. Additionally, the gaseous components in the products of the aerosol extinguishing agent also play a supportive role.

Cooling Fire Extinguishing Effect from Endothermic Decomposition

The cooling effect of thermal aerosol extinguishing agents is primarily due to the endothermic decomposition of metal oxides and carbonates. When a fire occurs, the solid particles in the aerosol rapidly absorb heat from the fire source, resulting in a decrease in flame temperature. This reduction minimizes the heat radiating to the burning surface and lowers the energy required to dissociate vaporized combustible materials into free radicals. As a result, the combustion reaction is effectively suppressed.

Gas Phase Chemical Suppression Effect

Under thermal conditions, vaporized metal ions, such as strontium (Sr), potassium (K), and magnesium (Mg), exist as vapors and participate in multiple chain reactions with active combustion radicals including hydrogen (H·), hydroxyl (·OH), and oxygen (O·). For example:

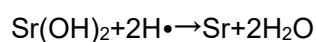
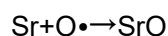
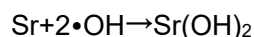

Through continuous action, this process consumes active combustion groups, significantly reducing their concentration and effectively suppressing combustion.

Solid Phase Chemical Suppression Effect

The solid particles in thermal aerosol extinguishing agents can adsorb intermediates such as $\bullet\text{OH}$, $\text{H}\bullet$, and $\text{O}\bullet$ from chain reactions, catalyzing their recombination into stable molecules. This interrupts the essential branching chain reactions in the combustion process. For example:

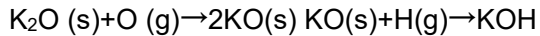
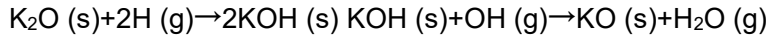

4.2 Technical Specifications

Activation method: Thermal activation

Thermal activation temperature: $\geq 170^\circ\text{C}$

Discharge time: ≤ 5 seconds

Notes:

Please contact Fox ESS for immediate replacement if the fire protection module is activated.

Non-professionals should not disassemble the battery without authorization.

Do not touch the device until the casing has cooled after the internal fire extinguisher has been activated to prevent burns.

For further assistance, please contact an authorized personnel or Fox ESS for further instructions.

5 Warm up Function

In low-temperature climates at high altitudes or latitudes, particularly during winter, the charging and discharging performance of batteries can significantly decline due to cold temperatures. To address this Fox ESS has introduced a "Battery Warm up" feature, enabling the battery system to operate effectively extremely low temperatures. This feature is exclusively available in the warm-up versions.

The battery warm-up interface in the APP

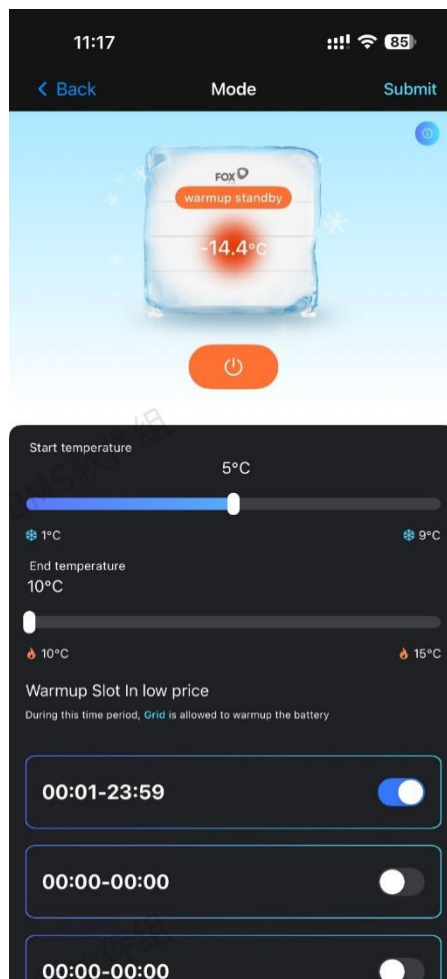

1. Warm-up main switch button;
2. Warm-up start temperature, eg.: temperature range 1~9°C optional;
3. Warm-up stop temperature, eg.: temperature range 10~15°C optional;
4. Three warm-up time periods can be set;
5. Battery warm-up status and minimum temperature display.

(a) Battery self warm-up state

If Battery SOC \geq 10% , MinCell Temperature $<$ Start Temperature , and not in low-temperature protection state , and within the set warm-up time.

Then the battery is in a self warm-up state, and the warm up function is powered by the battery itself. At this time, the inverter power control is not affected.

(b) Inverter controls warm-up state

If Battery SOC $<$ 10% or in low-temperature protection state, and MinCell Temperature $<$ Start Temperature and within the set warm-up time.

Then the battery is in an inverter controlled warm-up state, and the warm up function is powered by the inverter. In this state, the inverter can only provide power for warming up the battery and cannot respond to other charging and discharging requests.

Control method:

The app or cloud platform transmits settings for the warm-up switch, warm-up activation temperature, shutdown temperature and warm-up activation time window to the PCS via the network; the PCS sends these settings to the BMS via the CAN protocol; the BMS controls the temperature based on these settings and uploads temperature-related status data to the PCS via CAN; the PCS then uploads this data to the app or cloud platform via the network.

- The battery can only discharge when the internal temperature of battery is above -10°C . It can only charge when the internal temperature of battery is above 0°C .
- Please check that the wiring is properly connected and that all batteries are the warm up versions; otherwise, the Warming up function will not operate.
- Warming up control is based on the internal cell temperature of the battery, rather than the ambient temperature. Typically, the cell temperature will be higher than the ambient temperature under normal operating conditions.

For further assistance, please contact an authorized personnel or Fox ESS for further instructions.

Note: Products with "(w)" suffix, such as CQ7-M-50 (w) and CQ7-S-50 (w) are equipped with Battery Warm up function. Without the "(w)" suffix, like CQ7-M-50 and CQ7-S-50 are not equipped with the Battery Warm up function.

6 Product Introduction

6.1 CQ7-50-Lx, (x=2~14) Specifications

- CQ7-S-50 is the battery module, and CQ7-M-50 includes system controller and battery module;
- CQ7-M-50 contains the controller of the entire system, so each system must have one CQ7-M-50;
- Ensure that each system has only 1 CQ7-M-50 and a maximum of 13 CQ7-S-50.







6.1.1 CQ7-S-50 Specifications

Specifications for CQ7-S-50	
Model No.	CQ7-S-50
Max. charge/discharge current (A)	50
Operating charge/discharge temperature (°C)	0~55/-10~55
Storage temperature (°C)	-10~50
Humidity (%)	5~95(No Condensing)
Nominal voltage (V)	57.6
Nominal capacity (Ah)	121
Nominal energy (kWh)	6.96
Battery voltage range (V)	52.2~65.7
Max. Continuous discharge/charge current (A)	50/50
(CC-CV) Standard charging current (A)	50
Short circuit current (kA)	2.9
Constant current and voltage charging cut-off current (A)	2
Depth of discharge(%)	100
Peak discharge current (60s) (A)	65
Altitude (m)	≤3000
Dimensions (W*H*D) (mm)	660*190*360
Tolerance (W*H*D) (mm)	±3/±3/±3
Weight (kg)	50.5*(1±5%)
Communication interfaces	CAN



6.1.2 CQ7-M-50 Specifications

Specifications for CQ7-M-50	
Model No.	CQ7-M-50
Max. charge/discharge current (A)	50
Operating charge/discharge temperature (°C)	0~55/-10~55
Storage temperature (°C)	-10~50
Humidity (%)	5~95(No Condensing)
Nominal voltage (V)	57.6
Nominal capacity (Ah)	121
Nominal energy (kWh)	6.96
Battery voltage range (V)	52.2~65.7
Max. Continuous discharge/charge current (A)	50/50
(CC-CV) Standard charging current (A)	50
Short circuit current (kA)	2.9
Constant current and voltage charging cut-off current (A)	2
Depth of discharge(%)	100
Peak discharge current (60s) (A)	65
Altitude (m)	≤3000
Dimensions (W*H*D) (mm)	660*205*360
Tolerance (W*H*D) (mm)	±3/±3/±3
Weight (kg)	55*(1±5%)
Communication interfaces	CAN

6.1.3 Battery System Specifications for CQ7-50-Lx, (x=2~14)

Specifications for CQ7-50-Lx, (x=2~8)							
Model No.	CQ7-50-L2	CQ7-50-L3	CQ7-50-L4	CQ7-50-L5	CQ7-50-L6	CQ7-50-L7	CQ7-50-L8
Technical Properties							
Battery designation	IFpP53/150/120[(18S)2S]E/-10+50/90	IFpP53/150/120[(18S)3S]E/-10+50/90	IFpP53/150/120[(18S)4S]E/-10+50/90	IFpP53/150/120[(18S)5S]E/-10+50/90	IFpP53/150/120[(18S)6S]E/-10+50/90	IFpP53/150/120[(18S)7S]E/-10+50/90	IFpP53/150/120[(18S)8S]E/-10+50/90
The number of batteries	1CQ7-M-50+1CQ7-S-50	1CQ7-M-50+2CQ7-S-50	1CQ7-M-50+3CQ7-S-50	1CQ7-M-50+4CQ7-S-50	1CQ7-M-50+5CQ7-S-50	1CQ7-M-50+6CQ7-S-50	1CQ7-M-50+7CQ7-S-50
Nominal voltage (V)	115.2	172.8	230.4	288.0	345.6	403.2	460.8
Nominal capacity (Ah)	121	121	121	121	121	121	121

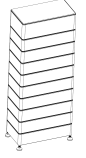
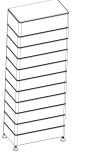
Nominal energy (kWh)	13.92	20.88	27.84	34.80	41.76	48.72	55.68
Battery voltage range (V)	104.4~131.4	156.6~197.1	208.8~262.8	261.0~328.5	313.2~394.2	365.4~459.9	417.6~525.6
Max. charge/discharge current (A)	50/50						
(CC-CV) Standard charging current (A)	50						
Constant current and constant voltage charging cut-off current (A)	2						
Peak discharge Current (60s) (A)	65						
Depth of discharge(%)	100						
Storage temperature (°C)	-10~50						
Operating charge/discharge temperature (°C)	0~55/-10~55						
Discharge capacity (Ah)	97.6@-20±2°C @1/3C ; 121@25±2°C @1/3C; 121@55±2°C @1/3C						
Cycle life	≥6000 @25°C @ 70%SOH						
Ingress protection	IP65						
Protective class	Class I						
Dimensions (W*H*D) (mm)	660*420*360	660*575*360	660*730*360	660*885*360	660*1040*360	660*1195*360	660*1350*360
Tolerance (W*H*D) (mm)	±3/±6/±3	±3/±9/±3	±3/±12/±3	±3/±15/±3	±3/±18/±3	±3/±21/±3	±3/±24/±3
Weight (kg)	105.5(1±5%)	156(1±5%)	206.5(1±5%)	257(1±5%)	307.5(1±5%)	358(1±5%)	408.5(1±5%)
Communication interfaces	CAN						

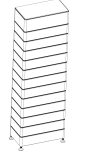
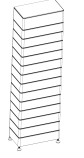
Specifications for CQ7-50-Lx, (x=9~14)						
Model No.	CQ7-50-L9	CQ7-50-L10	CQ7-50-L11	CQ7-50-L12	CQ7-50-L13	CQ7-50-L14
Technical Properties						
Battery designation	IFpP53/150/12 0[(18S)9S]E/-1 0+50/90	IFpP53/150/12 0[(18S)10S]E/- 10+50/90	IFpP53/150/1 20[(18S)11S] E/-10+50/90	IFpP53/150/12 0[(18S)12S]E/- 10+50/90	IFpP53/150/120 [(18S)13S]E/-10 +50/90	IFpP53/150/120[(18S)14S]E/-10+ 50/90
The number of batteries	1CQ7-M-50+8 CQ7-S-50	1CQ7-M-50+9 CQ7-S-50	1CQ7-M-50+1 0CQ7-S-50	1CQ7-M-50+11 CQ7-S-50	1CQ7-M-50+12 CQ7-S-50	1CQ7-M-50+13 CQ7-S-50
Nominal voltage (V)	518.4	576.0	633.6	691.2	748.8	806.4
Nominal capacity (Ah)	121	121	121	121	121	121
Nominal energy (kWh)	62.64	69.60	76.56	83.52	90.48	97.44
Battery voltage range (V)	469.8~591.3	522.0~657.0	574.2~722.7	626.4~788.4	678.6~854.1	730.8~919.8
Max. charge/discharge current (A)	50/50					
(CC-CV) Standard charging current (A)	50					
Constant current and constant voltage charging cut-off current (A)	2					
Peak discharge Current (60s) (A)	65					
Depth of discharge(%)	100					
Storage temperature (°C)	-10~50					
Operating charge/discharge temperature (°C)	0~55/-10~55					
Discharge capacity (Ah)	97.6@-20±2°C @1/3C ; 121@25±2°C @1/3C; 121@55±2°C @1/3C					
Cycle life	≥6000 @25°C @ 70%SOH					
Ingress protection	IP65					
Protective class	Class I					
Dimensions (W*H*D) (mm)	660*1505*360	660*1660*360	660*1815*360	660*1970*360	660*2125*360	660*2280*360
Tolerance (W*H*D) (mm)	±3/±27/±3	±3/±30/±3	±3/±33/±3	±3/±36/±3	±3/±39/±3	±3/±42/±3
Weight (kg)	459(1±5%)	509.5(1±5%)	560(1±5%)	610.5(1±5%)	661(1±5%)	711.5(1±5%)
Communication interfaces	CAN					

6.2 CQ7-50-Lx (w), (x=2~14) Specifications

- CQ7-S-50 (w) is the battery module, and CQ7-M-50 (w) includes system controller and battery module;
- CQ7-M-50 (w) contains the controller of the entire system, so each system must have one CQ7-M-50 (w);
- Ensure that each system has only 1 CQ7-M-50 (w) and a maximum of 13 CQ7-S-50 (w).







6.2.1 CQ7-S-50 (w) Specifications

Specifications for CQ7-S-50 (w)	
Model No.	CQ7-S-50 (w)
Max. charge/discharge current (A)	50
Operating charge/discharge temperature (°C)	0~55/-10~55 ^{*1} -25~55/-25~55 ^{*2}
Storage temperature (°C)	-10~50
Humidity (%)	5~95(No Condensing)
Nominal voltage (V)	57.6
Nominal capacity (Ah)	121
Nominal energy (kWh)	6.96
Battery voltage range (V)	52.2~65.7
Max. Continuous discharge/charge current (A)	50/50
(CC-CV) Standard charging current (A)	50
Short circuit current (kA)	2.9
Constant current and voltage charging cut-off current (A)	2
Depth of discharge(%)	100
Peak discharge current (60s) (A)	65
Altitude (m)	≤3000
Dimensions (W*H*D) (mm)	660*190*360
Tolerance (W*H*D) (mm)	±3/±3/±3
Weight (kg)	50.5*(1±5%)
Communication interfaces	CAN
* ¹ warm up function off * ² warm up function on	

6.2.2 CQ7-M-50 (w) Specifications

Specifications for CQ7-M-50 (w)	
Model No.	CQ7-M-50 (w)
Max. charge/discharge current (A)	50
Operating charge/discharge temperature (°C)	0~55/-10~55 ^{*1} -25~55/-25~55 ^{*2}
Storage temperature (°C)	-10~50
Humidity (%)	5~95(No Condensing)
Nominal voltage (V)	57.6
Nominal capacity (Ah)	121
Nominal energy (kWh)	6.96
Battery voltage range (V)	52.2~65.7
Max. Continuous discharge/charge current (A)	50/50
(CC-CV) Standard charging current (A)	50
Short circuit current (kA)	2.9
Constant current and voltage charging cut-off current (A)	2
Depth of discharge(%)	100
Peak discharge current (60s) (A)	65
Altitude (m)	≤3000
Dimensions (W*H*D) (mm)	660*205*360
Tolerance (W*H*D) (mm)	±3/±3/±3
Weight (kg)	55*(1±5%)
Communication interfaces	CAN
*1warm up function off *2warm up function on	

6.2.3 Battery System Specifications for CQ7-50-Lx (w), (x=2~14)

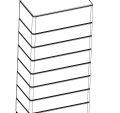
Specifications for CQ7-50-Lx (w), (x=2~8)							
Model No.	CQ7-50-L2 (w)	CQ7-50-L3 (w)	CQ7-50-L4 (w)	CQ7-50-L5 (w)	CQ7-50-L6 (w)	CQ7-50-L7 (w)	CQ7-50-L8 (w)
Technical Properties							
Battery designation	IFpP53/150/12 0[(18S)2S]E/-1 0+50/90	IFpP53/150/12 0[(18S)3S]E/-1 0+50/90	IFpP53/150/12 0[(18S)4S]E/-1 0+50/90	IFpP53/150/12 0[(18S)5S]E/-1 0+50/90	IFpP53/150/12 0[(18S)6S]E/-1 0+50/90	IFpP53/150/12 0[(18S)7S]E/-1 0+50/90	IFpP53/150/12 0[(18S)8S]E/-1 0+50/90
The number of	1CQ7-M-50	1CQ7-M-50	1CQ7-M-50	1CQ7-M-50	1CQ7-M-50	1CQ7-M-50	1CQ7-M-50

batteries	(w)+1CQ7-S-5 0 (w)	(w)+2CQ7-S-5 0 (w)	(w)+3CQ7-S-5 0 (w)	(w)+4CQ7-S-5 0 (w)	(w)+5CQ7-S-5 0 (w)	(w)+6CQ7-S-5 0 (w)	(w)+7CQ7-S-5 0 (w)
Nominal voltage (V)	115.2	172.8	230.4	288.0	345.6	403.2	460.8
Nominal capacity (Ah)	121	121	121	121	121	121	121
Nominal energy (kWh)	13.92	20.88	27.84	34.80	41.76	48.72	55.68
Battery voltage range (V)	104.4~131.4	156.6~197.1	208.8~262.8	261.0~328.5	313.2~394.2	365.4~459.9	417.6~525.6
Max. charge/discharge current (A)	50/50						
(CC-CV) Standard charging current (A)	50						
Constant current and constant voltage charging cut-off current (A)	2						
Peak discharge Current (60s) (A)	65						
Depth of discharge(%)	100						
Storage temperature (°C)	-10~50						
Operating charge/discharge temperature (°C)	0~55/-10~55*1 -25~55/-25~55*2						
Discharge capacity (Ah)	97.6@-20±2°C @1/3C ; 121@25±2°C @1/3C; 121@55±2°C @1/3C						
Cycle life	≥6000 @25°C @ 70%SOH						
Ingress protection	IP65						
Protective class	Class I						
Dimensions (W*H*D) (mm)	660*420*360	660*575*360	660*730*360	660*885*360	660*1040*360	660*1195*360	660*1350*360
Tolerance (W*H*D) (mm)	±3/±6/±3	±3/±9/±3	±3/±12/±3	±3/±15/±3	±3/±18/±3	±3/±21/±3	±3/±24/±3
Weight (kg)	105.5(1±5%)	156(1±5%)	206.5(1±5%)	257(1±5%)	307.5(1±5%)	358(1±5%)	408.5(1±5%)
Communication interfaces	CAN						
*1 warm up function off *2 warm up function on							

Specifications for CQ7-50-Lx (w), (x=9~14)

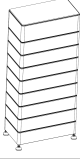
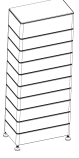
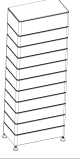
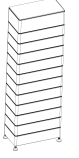
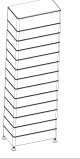
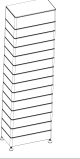
Model No.	CQ7-50-L9 (w)	CQ7-50-L10 (w)	CQ7-50-L11 (w)	CQ7-50-L12 (w)	CQ7-50-L13 (w)	CQ7-50-L14 (w)
Technical Properties						
Battery designation	IFpP53/150/120[(18S)9S]E/-10+50/90	IFpP53/150/120[(18S)10S]E/-10+50/90	IFpP53/150/120[(18S)11S]E/-10+50/90	IFpP53/150/120[(18S)12S]E/-10+50/90	IFpP53/150/120[(18S)13S]E/-10+50/90	IFpP53/150/120[(18S)14S]E/-10+50/90
The number of batteries	1CQ7-M-50 (w)+8CQ7-S-50 (w)	1CQ7-M-50 (w)+9CQ7-S-50 (w)	1CQ7-M-50 (w)+10CQ7-S-50 (w)	1CQ7-M-50 (w)+11CQ7-S-50 (w)	1CQ7-M-50 (w)+12CQ7-S-50 (w)	1CQ7-M-50 (w)+13CQ7-S-50 (w)
Nominal voltage (V)	518.4	576.0	633.6	691.2	748.8	806.4
Nominal capacity (Ah)	121	121	121	121	121	121
Nominal energy (kWh)	62.64	69.60	76.56	83.52	90.48	97.44
Battery voltage range (V)	469.8~591.3	522.0~657.0	574.2~722.7	626.4~788.4	678.6~854.1	730.8~919.8
Max. charge/discharge current (A)	50/50					
(CC-CV) Standard charging current (A)	50					
Constant current and constant voltage charging cut-off current (A)	2					
Peak discharge Current (60s) (A)	65					
Depth of discharge(%)	100					
Storage temperature (°C)	-10~50					
Operating charge/discharge temperature (°C)	0~55/-10~55*1 -25~55/-25~55*2					
Discharge capacity (Ah)	97.6@-20±2°C @1/3C ; 121@25±2°C @1/3C; 121@55±2°C @1/3C					
Cycle life	≥6000 @25°C @ 70%SOH					
Ingress protection	IP65					
Protective class	Class I					
Dimensions (W*H*D) (mm)	660*1505*360	660*360*1660*360	660*1815*360	660*1970*360	660*2125*360	660*2280*360
Tolerance (W*H*D) (mm)	±3/±27/±3	±3/±30/±3	±3/±33/±3	±3/±36/±3	±3/±39/±3	±3/±42/±3
Weight (kg)	459(1±5%)	509.5(1±5%)	560(1±5%)	610.5(1±5%)	661(1±5%)	711.5(1±5%)
Communication interfaces	CAN					
	*1 warm up function off *2 warm up function on					

6.3 CQ7-Lx, (x=2~14) Specifications

- CQ7-S is the battery module, and CQ7-M includes system controller and battery module;
- CQ7-M contains the controller of the entire system, so each system must have one CQ7-M;
- Ensure that each system has only 1 CQ7-M and a maximum of 13 CQ7-S.







6.3.1 CQ7-S Specifications

Specifications for CQ7-S	
Model No.	CQ7-S
Max. charge/discharge current (A)	80
Operating charge/discharge temperature (°C)	0~55/-10~55
Storage temperature (°C)	-10~50
Humidity (%)	5~95(No Condensing)
Nominal voltage (V)	57.6
Nominal capacity (Ah)	121
Nominal energy (kWh)	6.96
Battery voltage range (V)	52.2~65.7
Max. Continuous discharge/charge current (A)	80/80
(CC-CV) Standard charging current (A)	50
Short circuit current (kA)	2.9
Constant current and voltage charging cut-off current (A)	2
Depth of discharge(%)	100
Peak discharge current (60s) (A)	120
Altitude (m)	≤3000
Dimensions (W*H*D) (mm)	660*190*360
Tolerance (W*H*D) (mm)	±3/±3/±3
Weight (kg)	50.5*(1±5%)
Communication interfaces	CAN



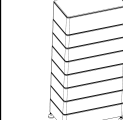

6.3.2 CQ7-M Specifications

Specifications for CQ7-M	
Model No.	CQ7-M
Max. charge/discharge current (A)	80
Operating charge/discharge temperature (°C)	0~55/-10~55
Storage temperature (°C)	-10~50
Humidity (%)	5~95(No Condensing)
Nominal voltage (V)	57.6
Nominal capacity (Ah)	121
Nominal energy (kWh)	6.96
Battery voltage range (V)	52.2~65.7
Max. Continuous discharge/charge current (A)	80/80
(CC-CV) Standard charging current (A)	50
Short circuit current (kA)	2.9
Constant current and voltage charging cut-off current (A)	2
Depth of discharge(%)	100
Peak discharge current (60s) (A)	120
Altitude (m)	≤3000
Dimensions (W*H*D) (mm)	660*205*360
Tolerance (W*H*D) (mm)	±3/±3/±3
Weight (kg)	55*(1±5%)
Communication interfaces	CAN

6.3.3 Battery System Specifications for CQ7-Lx, (x=2~14)

Specifications for CQ7-Lx, (x=2~8)							
Model No.	CQ7-L2	CQ7-L3	CQ7-L4	CQ7-L5	CQ7-L6	CQ7-L7	CQ7-L8
Technical Properties							
Battery designation	IFpP53/150/120[(18S)2S]M/-10+50/90	IFpP53/150/120[(18S)3S]EM/-10+50/90	IFpP53/150/120[(18S)4S]M/-10+50/90	IFpP53/150/120[(18S)5S]M/-10+50/90	IFpP53/150/120[(18S)6S]JM/-10+50/90	IFpP53/150/120[(18S)7S]JM/-10+50/90	IFpP53/150/120[(18S)8S]JM/-10+50/90
The number of batteries	1CQ7-M+1CQ7-S	1CQ7-M+2CQ7-S	1CQ7-M+3CQ7-S	1CQ7-M+4CQ7-S	1CQ7-M+5CQ7-S	1CQ7-M+6CQ7-S	1CQ7-M+7CQ7-S
Nominal voltage (V)	115.2	172.8	230.4	288.0	345.6	403.2	460.8
Nominal capacity (Ah)	121	121	121	121	121	121	121

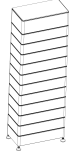
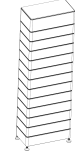
Nominal energy (kWh)	13.92	20.88	27.84	34.80	41.76	48.72	55.68
Battery voltage range (V)	104.4~131.4	156.6~197.1	208.8~262.8	261.0~328.5	313.2~394.2	365.4~459.9	417.6~525.6
Max. charge/discharge current (A)	80/80						
(CC-CV) Standard charging current (A)	50						
Constant current and constant voltage charging cut-off current (A)	2						
Peak discharge Current (60s) (A)	120						
Depth of discharge(%)	100						
Storage temperature (°C)	-10~50						
Operating charge/discharge temperature (°C)	0~55/-10~55						
Discharge capacity (Ah)	97.6@-20±2°C @1/3C ; 121@25±2°C @1/3C; 121@55±2°C @1/3C						
Cycle life	≥6000 @25°C @ 70%SOH						
Ingress protection	IP65						
Protective class	Class I						
Dimensions (W*H*D) (mm)	660*420*360	660*575*360	660*730*360	660*885*360	660*1040*360	660*1195*360	660*1350*360
Tolerance (W*H*D) (mm)	±3/±6/±3	±3/±9/±3	±3/±12/±3	±3/±15/±3	±3/±18/±3	±3/±21/±3	±3/±24/±3
Weight (kg)	105.5(1±5%)	156(1±5%)	206.5(1±5%)	257(1±5%)	307.5(1±5%)	358(1±5%)	408.5(1±5%)
Communication interfaces	CAN						

Specifications for CQ7-Lx, (x=9~14)						
Model No.	CQ7-L9	CQ7-L10	CQ7-L11	CQ7-L12	CQ7-L13	CQ7-L14
Technical Properties						
Battery designation	IFpP53/150/12 0[(18S)9S]M/ -10+50/90	IFpP53/150/12 0[(18S)10S]M/ -10+50/90	IFpP53/150/12 0[(18S)11S]M/ -10+50/90	IFpP53/150/12 0[(18S)12S]M/ -10+50/90	IFpP53/150/120 [(18S)13S]M/-1 0+50/90	IFpP53/150/120[(18S)14S]M/-10 +50/90
The number of batteries	1CQ7-M+8CQ 7-S	1CQ7-M+9CQ 7-S	1CQ7-M+10C Q7-S	1CQ7-M+11C Q7-S	1CQ7-M+12CQ 7-S	1CQ7-M+13CQ 7-S
Nominal voltage (V)	518.4	576.0	633.6	691.2	748.8	806.4
Nominal capacity (Ah)	121	121	121	121	121	121
Nominal energy (kWh)	62.64	69.60	76.56	83.52	90.48	97.44
Battery voltage range (V)	469.8~591.3	522.0~657.0	574.2~722.7	626.4~788.4	678.6~854.1	730.8~919.8
Max. charge/discharge current (A)	80/80					
(CC-CV) Standard charging current (A)	50					
Constant current and constant voltage charging cut-off current (A)	2					
Peak discharge Current (60s) (A)	120					
Depth of discharge(%)	100					
Storage temperature (°C)	-10~50					
Operating charge/discharge temperature (°C)	0~55/-10~55					
Discharge capacity (Ah)	97.6@-20±2°C @1/3C ; 121@25±2°C @1/3C; 121@55±2°C @1/3C					
Cycle life	≥6000 @25°C @ 70%SOH					
Ingress protection	IP65					
Protective class	Class I					
Dimensions (W*H*D) (mm)	660*1505*360	660*1660*360	660*1815*360	660*1970*360	660*2125*360	660*2280*360
Tolerance (W*H*D) (mm)	±3/±27/±3	±3/±30/±3	±3/±33/±3	±3/±36/±3	±3/±39/±3	±3/±42/±3
Weight (kg)	459(1±5%)	509.5(1±5%)	560(1±5%)	610.5(1±5%)	661(1±5%)	711.5(1±5%)
Communication interfaces	CAN					

6.4 CQ7-Lx (w), (x=2~14) Specifications

- CQ7-S (w) is the battery module, and CQ7-M (w) includes system controller and battery module;
- CQ7-M (w) contains the controller of the entire system, so each system must have one CQ7-M (w);
- Ensure that each system has only 1 CQ7-M (w) and a maximum of 13 CQ7-S (w).







6.4.1 CQ7-S (w) Specifications

Specifications for CQ7-S (w)	
Model No.	CQ7-S (w)
Max. charge/discharge current (A)	80
Operating charge/discharge temperature (°C)	0~55/-10~55 ^{*1} -25~55/-25~55 ^{*2}
Storage temperature (°C)	-10~50
Humidity (%)	5~95(No Condensing)
Nominal voltage (V)	57.6
Nominal capacity (Ah)	121
Nominal energy (kWh)	6.96
Battery voltage range (V)	52.2~65.7
Max. Continuous discharge/charge current (A)	80/80
(CC-CV) Standard charging current (A)	50
Short circuit current (kA)	2.9
Constant current and voltage charging cut-off current (A)	2
Depth of discharge(%)	100
Peak discharge current (60s) (A)	120
Altitude (m)	≤3000
Dimensions (W*H*DH) (mm)	660*190*360
Tolerance (W*H*D) (mm)	±3/±3/±3
Weight (kg)	50.5*(1±5%)
Communication interfaces	CAN
*1warm up function off *2warm up function on	

6.4.2 CQ7-M (w) Specifications

Specifications for CQ7-M (w)	
Model No.	CQ7-M (w)
Max. charge/discharge current (A)	80
Operating charge/discharge temperature (°C)	0~55/-10~55 ^{*1} -25~55/-25~55 ^{*2}
Storage temperature (°C)	-10~50
Humidity (%)	5~95(No Condensing)
Nominal voltage (V)	57.6
Nominal capacity (Ah)	121
Nominal energy (kWh)	6.96
Battery voltage range (V)	52.2~65.7
Max. Continuous discharge/charge current (A)	80/80
(CC-CV) Standard charging current (A)	50
Short circuit current (kA)	2.9
Constant current and voltage charging cut-off current (A)	2
Depth of discharge(%)	100
Peak discharge current (60s) (A)	120
Altitude (m)	≤3000
Dimensions (W*H*D) (mm)	660*205*360
Tolerance (W*H*D) (mm)	±3/±3/±3
Weight (kg)	55*(1±5%)
Communication interfaces	CAN
*1warm up function off *2warm up function on	

6.4.3 Battery System Specifications for CQ7-Lx (w), (x=2~14)

Specifications for CQ7 -Lx (w), (x=2~8)							
Model No.	CQ7-L2 (w)	CQ7-L3 (w)	CQ7-L4 (w)	CQ7-L5 (w)	CQ7-L6 (w)	CQ7-L7 (w)	CQ7-L8 (w)
Technical Properties							
Battery designation	IFpP53/150/12 0[(18S)2S]M/ 10+50/90	IFpP53/150/12 0[(18S)3S]M/ 10+50/90	IFpP53/150/12 0[(18S)4S]M/ 10+50/90	IFpP53/150/12 0[(18S)5S]M/ 10+50/90	IFpP53/150/12 0[(18S)6S]M/-1 0+50/90	IFpP53/150/12 0[(18S)7S]M/ 10+50/90	IFpP53/150/12 0[(18S)8S]M/-1 0+50/90
The number of batteries	1CQ7-M (w)+1CQ7-S (w)	1CQ7-M (w)+2CQ7-S (w)	1CQ7-M (w)+3CQ7-S (w)	1CQ7-M (w)+4CQ7-S (w)	1CQ7-M (w)+5CQ7-S (w)	1CQ7-M (w)+6CQ7-S (w)	1CQ7-M (w)+7CQ7-S (w)
Nominal voltage (V)	115.2	172.8	230.4	288.0	345.6	403.2	460.8
Nominal capacity	121	121	121	121	121	121	121

(Ah)							
Nominal energy (kWh)	13.92	20.88	27.84	34.80	41.76	48.72	55.68
Battery voltage range (V)	104.4~131.4	156.6~197.1	208.8~262.8	261.0~328.5	313.2~394.2	365.4~459.9	417.6~525.6
Max. charge/discharge current (A)	80/80						
(CC-CV) Standard charging current (A)	50						
Constant current and constant voltage charging cut-off current (A)	2						
Peak discharge Current (60s) (A)	120						
Depth of discharge(%)	100						
Storage temperature (°C)	-10~50						
Operating charge/discharge temperature (°C)	0~55/-10~55* ¹ -25~55/-25~55* ²						
Discharge capacity (Ah)	97.6@-20±2°C @1/3C ; 121@25±2°C @1/3C; 121@55±2°C @1/3C						
Cycle life	≥6000 @25°C @ 70%SOH						
Ingress protection	IP65						
Protective class	Class I						
Dimensions (W*H*D) (mm)	660*420*360	660*575*360	660*730*360	660*885*360	660*1040*360	660*1195*360	660*1350*360
Tolerance (W*H*DH) (mm)	±3/±6/±3	±3/±9/±3	±3/±12/±3	±3/±15/±3	±3/±18/±3	±3/±21/±3	±3/±24/±3
Weight (kg)	105.5(1±5%)	156(1±5%)	206.5(1±5%)	257(1±5%)	307.5(1±5%)	358(1±5%)	408.5(1±5%)
Communication interfaces	CAN						
* ¹ warm up function off * ² warm up function on							

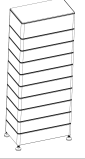
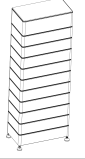
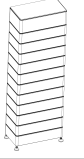
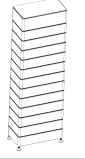
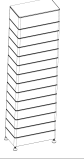
Specifications for CQ7-Lx (w), (x=9~14)						
Model No.	CQ7-L9 (w)	CQ7-L10 (w)	CQ7-L11 (w)	CQ7-L12 (w)	CQ7-L13 (w)	CQ7-L14 (w)
Technical Properties						
Battery designation	IFpP53/150/120[(18S)9S]M/-10+50/90	IFpP53/150/120[(18S)10S]M/-10+50/90	IFpP53/150/120[(18S)11S]M/-10+50/90	IFpP53/150/120[(18S)12S]M/-10+50/90	IFpP53/150/120[(18S)13S]M/-10+50/90	IFpP53/150/120[(18S)14S]M/-10+50/90
The number of batteries	1CQ7-M (w)+8CQ7-S (w)	1CQ7-M (w)+9CQ7-S (w)	1CQ7-M (w)+10CQ7-S (w)	1CQ7-M (w)+11CQ7-S (w)	1CQ7-M (w)+12CQ7-S (w)	1CQ7-M (w)+13CQ7-S (w)
Nominal voltage (V)	518.4	576.0	633.6	691.2	748.8	806.4
Nominal capacity (Ah)	121	121	121	121	121	121
Nominal energy (kWh)	62.64	69.60	76.56	83.52	90.48	97.44
Battery voltage range (V)	469.8~591.3	522.0~657.0	574.2~722.7	626.4~788.4	678.6~854.1	730.8~919.8
Max. charge/discharge current (A)	80/80					
(CC-CV) Standard charging current (A)	50					
Constant current and constant voltage charging cut-off current (A)	2					
Peak discharge Current (60s) (A)	120					
Depth of discharge(%)	100					
Storage temperature (°C)	-10~50					
Operating charge/discharge temperature (°C)	0~55/-10~55*1 -25~55/-25~55*2					
Discharge capacity (Ah)	97.6@-20±2°C @1/3C ; 121@25±2°C @1/3C; 121@55±2°C @1/3C					
Cycle life	≥6000 @25°C @ 70%SOH					
Ingress protection	IP65					
Protective class	Class I					
Dimensions (W*H*D)(mm)	660*1505*360	660*1660*360	660*1815*360	660*1970*360	660*2125*360	660*2280*360
Tolerance (W*H*D) (mm)	±3/±27/±3	±3/±30/±3	±3/±33/±3	±3/±36/±3	±3/±39/±3	±3/±42/±3
Weight (kg)	459(1±5%)	509.5(1±5%)	560(1±5%)	610.5(1±5%)	661(1±5%)	711.5(1±5%)
Communication interfaces	CAN					
*1 warm up function off *2 warm up function on						

7 Product Features

7.1 Battery System Features

The batteries have been fitted with multiple protection systems to ensure the safe operation of the system. Some of the protection system includes:

- Inverter interface protection: Over Voltage, Over Current, External Short Circuit, Reverse Polarity, Ground Fault, Over Temp, In Rush Current.
- Battery protection: Internal Short Circuit, Over Voltage, Over Current, Over Temp, Under Voltage.

The battery system contains the following Interface to allow it to connect and operate efficiently.

CQ7-S-50/CQ7-S-50 (w)/CQ7-S/CQ7-S (w) Features:

- interface:

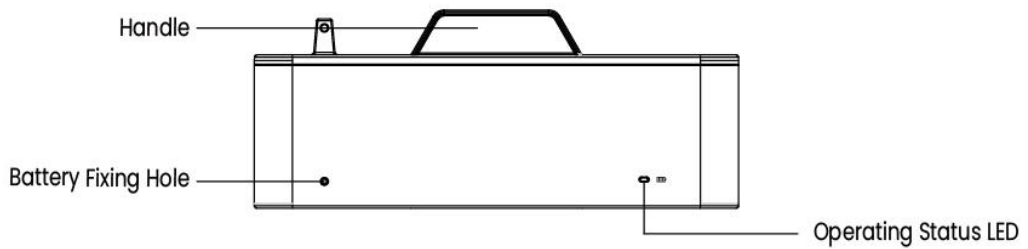

CQ7-M-50/CQ7-M-50 (w)/CQ7-M/CQ7-M (w) Features:

- interface:

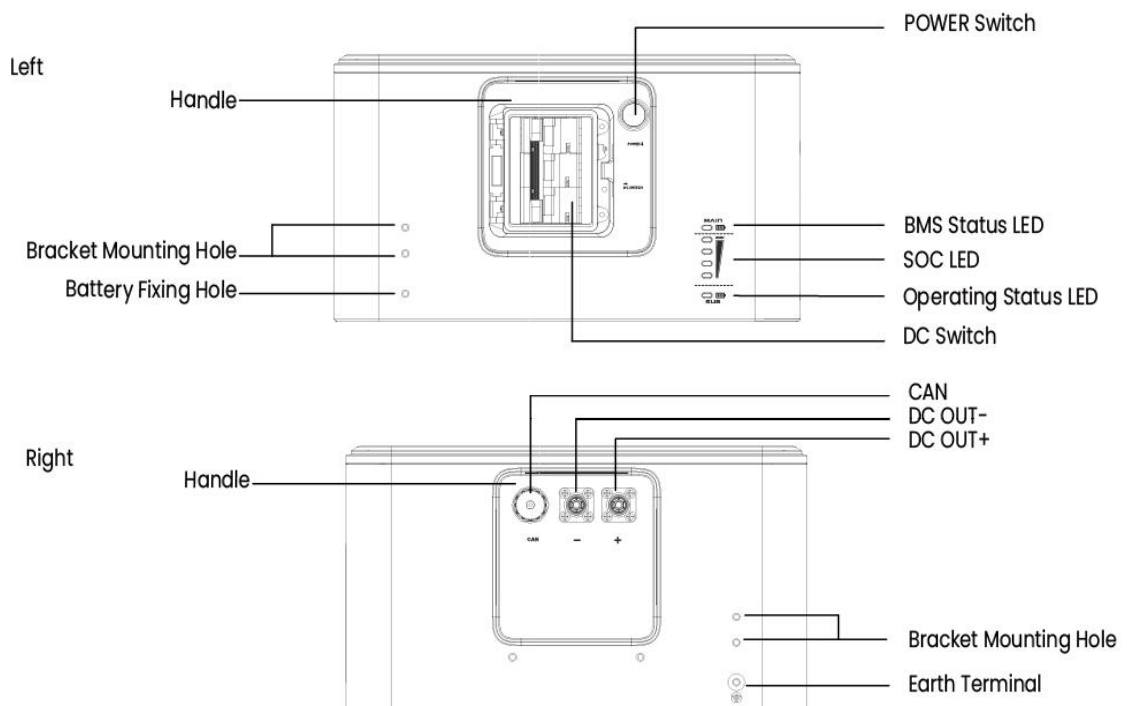

DC Switch

Power switch, battery charge and discharge circuit switch.

DC OUT +

Connect bat + of inverter.

DC OUT -

Connect bat - of inverter.

POWER Switch

System power on switch, press and hold switch for 3 seconds, and then release the switch, the system starts to work.

BMS Status LED and SOC LED

LED display specific alarm information and battery system power.

Operating status LED

This LED is used to indicate if the battery is operating effectively. A green light on this LED means the battery is ON and operating normally. If the battery is operating failure, a red light on this LED means the battery is operating abnormally.

8 Installation

8.1 Items in the package

Please check if following items are including with the package:

For CQ7-S-50/CQ7-S-50 (w)/CQ7-S/CQ7-S (w)



For CQ7-M-50/CQ7-M-50 (w)/CQ7-M/CQ7-M (w)

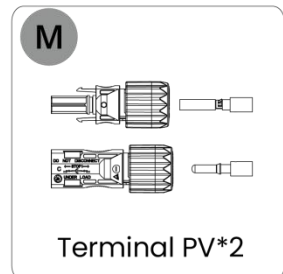
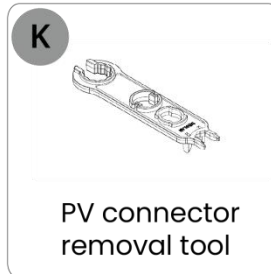
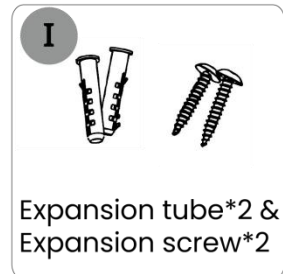
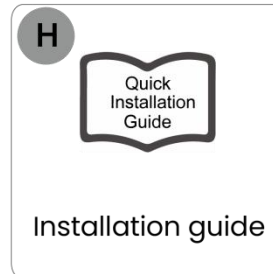
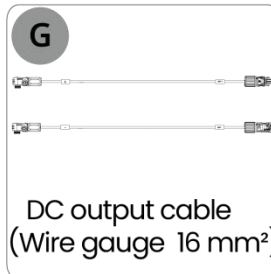
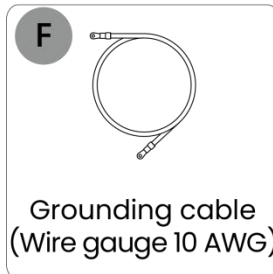
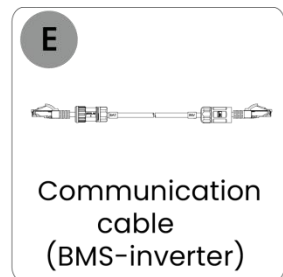
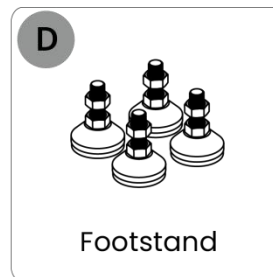
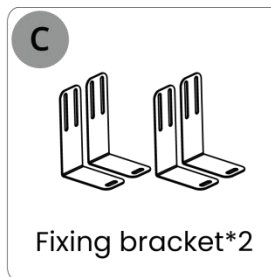
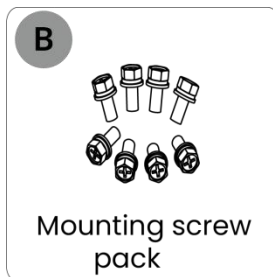

Note: Item K and item M are use for inverter installation.

8.2 Clearance

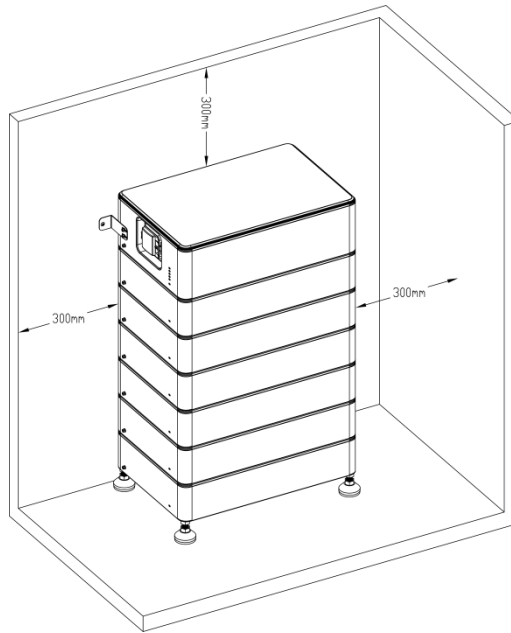

Note:

- Make sure to leave a space of at least 300mm. A clearance of at least 300mm must be left around the battery pack for proper cooling.
- Installation clearance requirements shall comply with local regulations.
- Make sure that the battery pack is always exposed to the ambient air. The battery pack is cooled by natural convection. If the battery pack is entirely or partially covered or shielded, it may cause the battery pack to stop operating.
- The safety clearance for equipment installation must comply with local regulations.
- The battery system must be kept at least 2 meters away from heat sources.

8.3 Tools

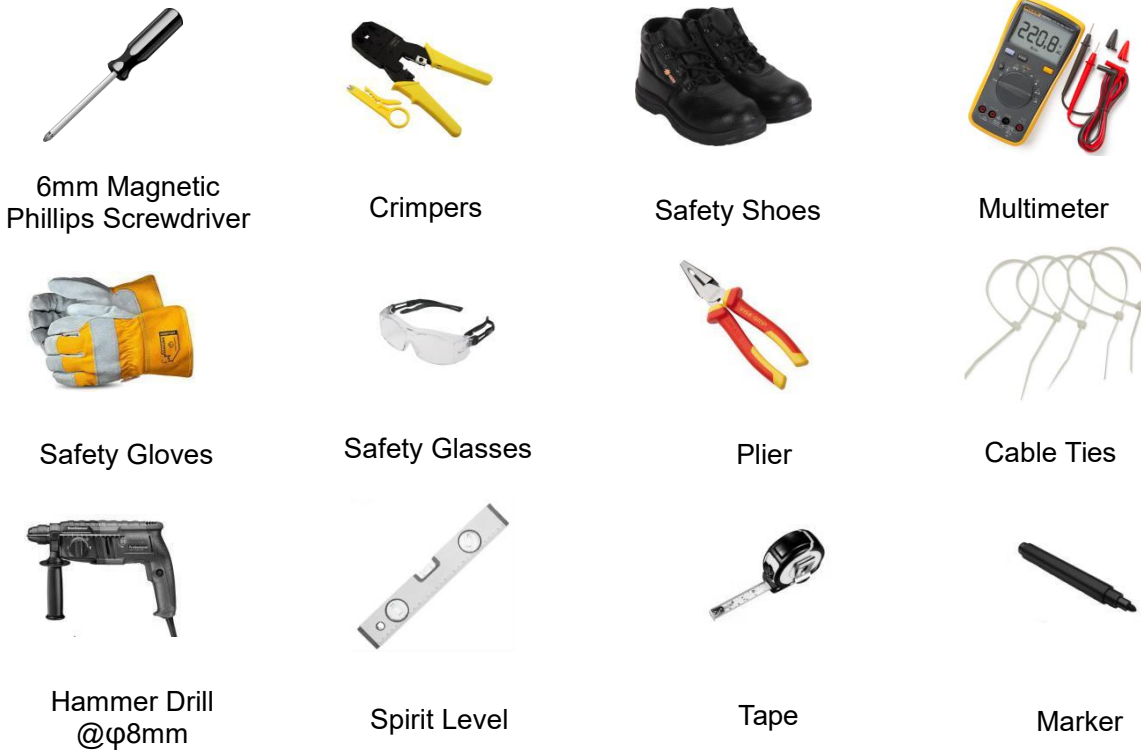

The following tools will be required to install CQ7-M-50/CQ7-M-50 (w)/CQ7-M/CQ7-M (w) and CQ7-S-50/CQ7-S-50 (w)/CQ7-S/CQ7-S (w).

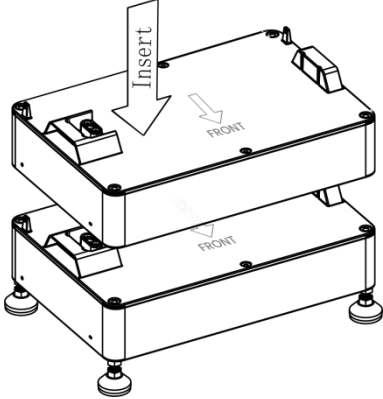
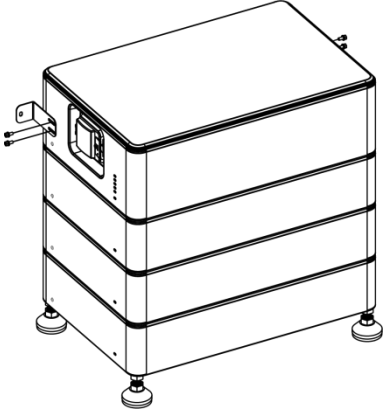
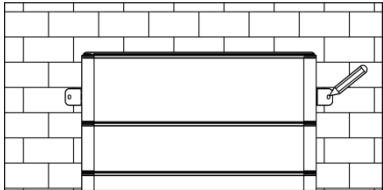
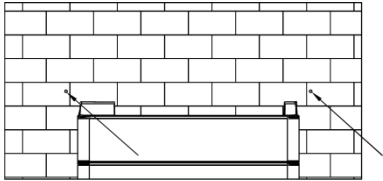

8.4 Installation Steps

Procedures		
<p>Step 1</p>	<p>Install a CQ7-S-50/CQ7-S-50 (w)/CQ7-S/CQ7-S (w) with four footstand (Item D) and place it on the ground and adjust it to the level. After installing the footstand, use a track level bar to confirm the level.</p>	
<p>Step 2</p>	<p>Place the battery 20mm against the wall. Note: Please make sure the Operating Status LED is on your left handside when you facing the battery model.</p>	

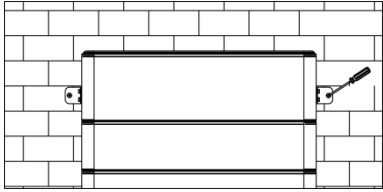
<p>Step 3</p>	<p>Stack the batteries one by one.</p>	
<p>Step 4</p>	<p>Place the two fixing brackets (Item C) close to the wall and install them on both sides of the battery.</p>	
<p>Step 5</p>	<p>Mark the wall through the bracket hole.</p>	
<p>Step 6</p>	<p>Punch after removing the CQ7-M-50/CQ7-M-50 (w)/CQ7-M/CQ7-M (w) . Drill holes with electric drill, make sure the holes are at least 50mm deep, and then tighten the expansion tubes (Item I).</p>	

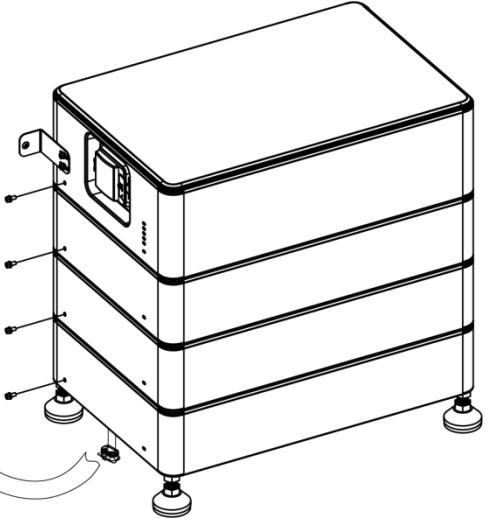
<p>Step 7</p>	<p>After stacking CQ7-M-50/CQ7-M-50 (w)/CQ7-M/CQ7-M (w) again, fix the battery on the wall.</p>	
<p>Step 8</p>	<p>Fix the mounting screw packs on both sides of the battery, the installation is over. Insert the waterproof cover (Item J) into the bottom of the battery and lock it in place with the clip, the installation is over.</p> <div style="display: flex; align-items: center;"> <div style="margin-right: 20px;">  <p>Notice: The screws must be installed.</p> </div> <div style="margin-right: 20px;">  <p>Notice: must be installed.</p> </div> <div>  </div> </div>	

Note: Please make sure each system is including one CQ7-M-50/CQ7-M-50 (w)/CQ7-M/CQ7-M (w) and at least one and at most thirteen CQ7-S-50/CQ7-S-50 (w)/CQ7-S/CQ7-S (w).

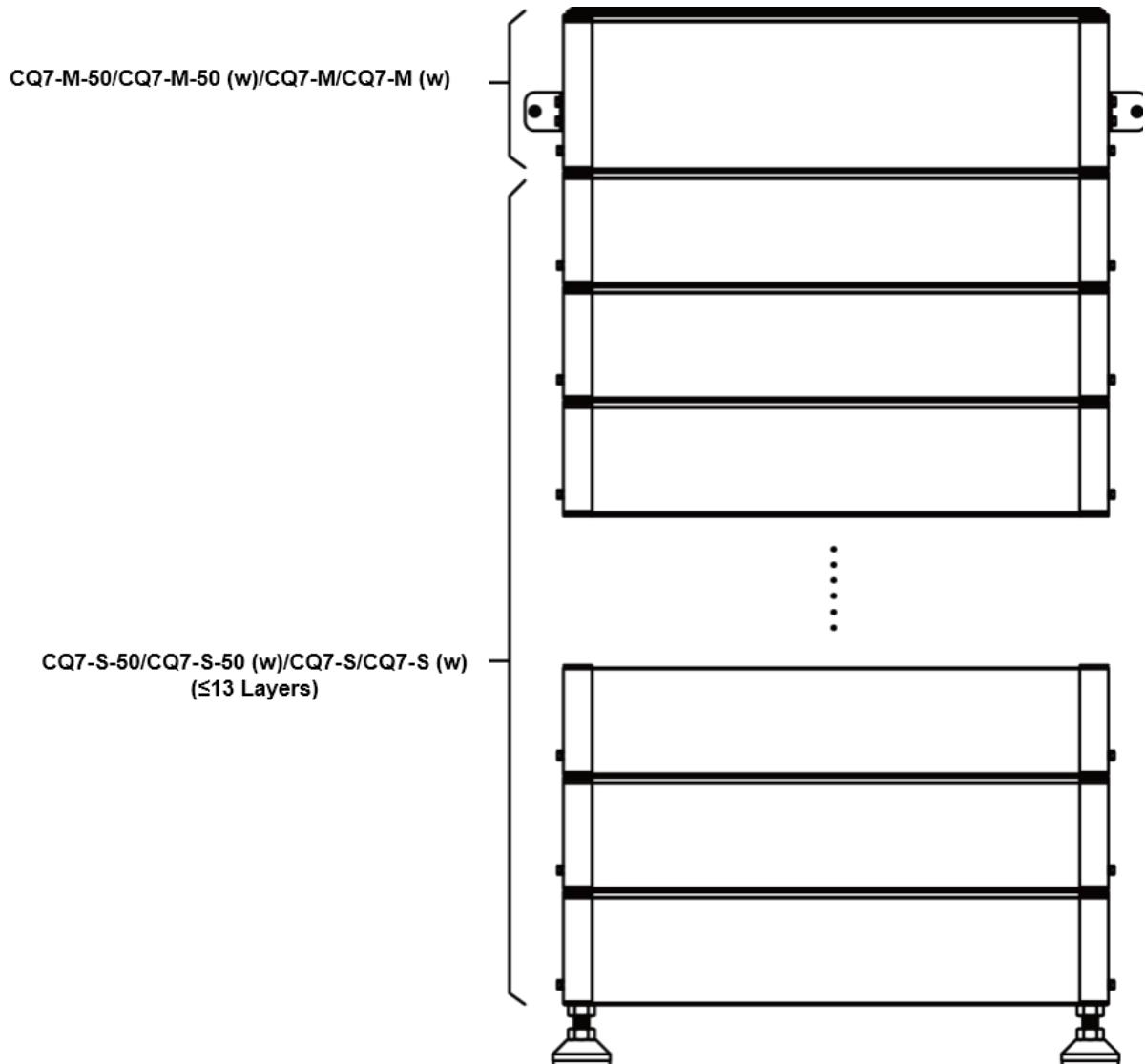

Note: Installation Location Instructions for fixing brackets (Item C):

- L : number of layers in the battery system.
- When $L \leq 6$, a pair of Item C is installed on CQ7-M-50/CQ7-M-50 (w)/CQ7-M/CQ7-M (w);
- When $L > 6$, a pair of Item C is installed on CQ7-M-50/CQ7-M-50 (w)/CQ7-M/CQ7-M (w), and install an additional pair of Item C in the middle layer of the CQ7-S-50/CQ7-S-50 (w)/CQ7-S/CQ7-S (w) modules.

Note: When used with an inverter, the battery system voltage must meet the inverter battery port voltage range.

8.5 Wiring Steps

Note: Please use the side labeled BAT to connect to the battery and the side labeled INV to connect to the inverter.

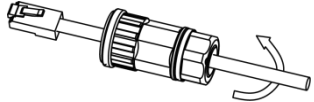
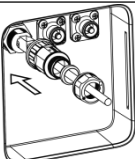
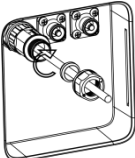
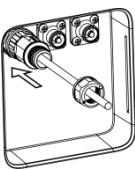
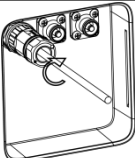
A. Communication cable installation procedure		
Step 1	Open the tail lock wire nut.	
Step 2	Plug communication cable RJ45 into the battery CAN port.	
Step 3	Use an open-end spanner to lock the body onto the RJ45 board end connector; torque: $1.2 \pm 0.2 \text{ N}\cdot\text{m}$.	
Step 4	Install the sealing plug into the main.	
Step 5	Use an open-end spanner to lock the thread locking nut onto the main body.	

Note: Please use the side labeled with “+” and “-” cable, i.e. right angle terminal to connect to the battery, and the side labeled with “BAT+” and “BAT-” cable to connect to the inverter.

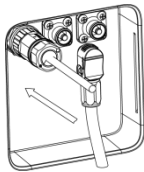
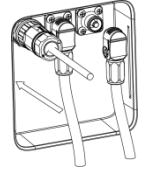
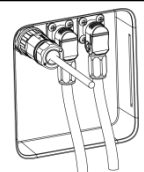
B. Power cable installation and fixing procedure		
Step 1	DC- output cable Installation.	
Step 2	DC+ output cable Installation.	
Step 3	DC output cable installation complete.	

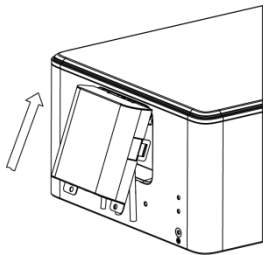
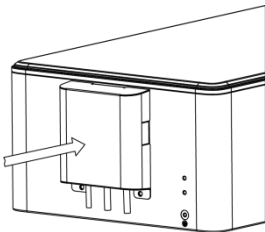
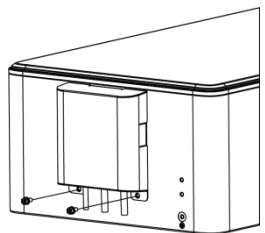
C. Power cable installation and fixing procedure		
Step 1	Put the communication cable and DC output cable into the wire slot of the protective cover and, at the same time, tilt the protective cover at a certain angle so that the clip on the top is clicking in to the housing slot.	
Step 2	Press down on the protective cover so that the tabs on both sides snap into the slots.	
Step 3	Secure the protective cover with screws.	

Insert the connector at the other end of the cable into the BMS port at the base of the inverter and tighten securely.

Note: Inverter wiring refer to the inverter user manual.

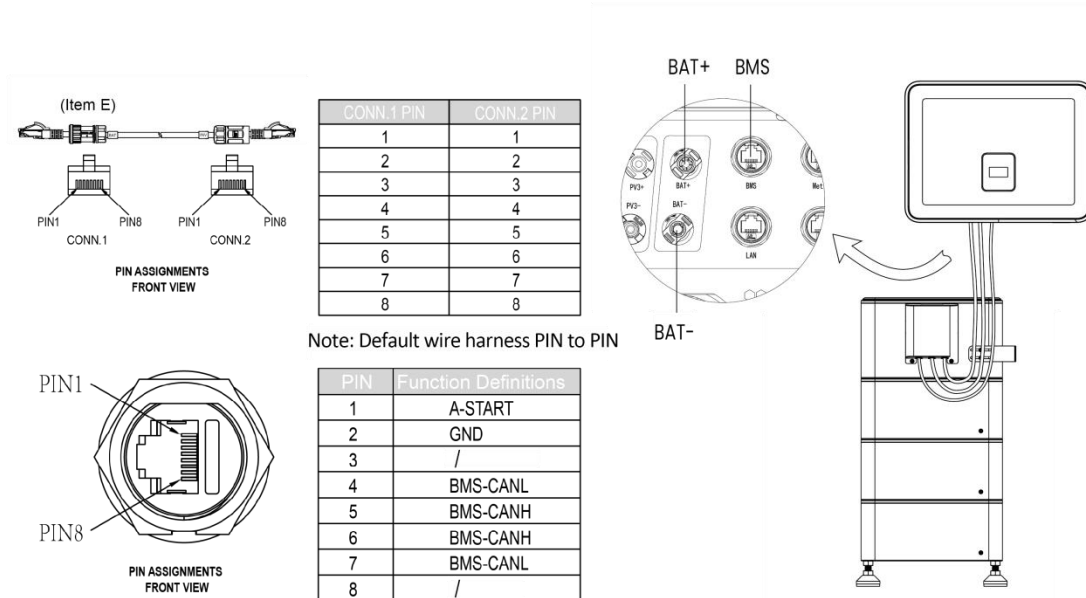

Note: If using a new RJ45 cable, the waterproof union nut can be removed from the communication cable (Item E) and placed into the new cable to ensure proper sealing.

Connect the grounding cable. The figure is shown in below.

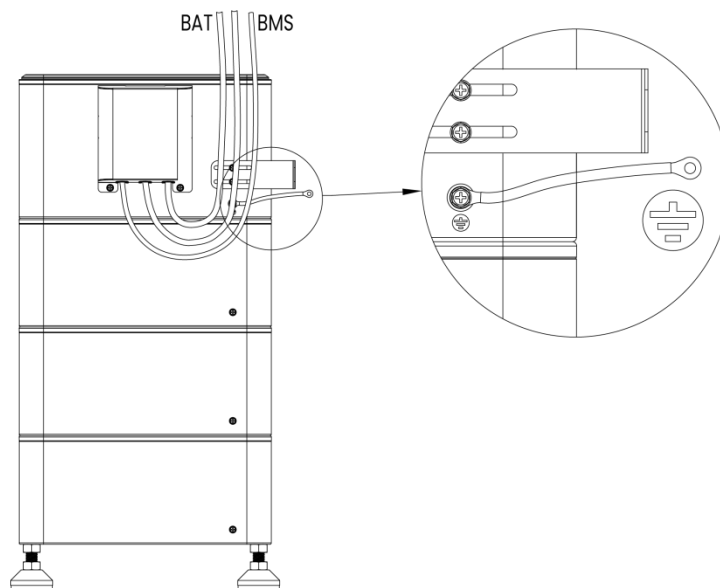

8.6 System Operation

- When the grid connected system is started, the inverter should be turned on first to avoid the current pulse of the inverter increasing to the battery pack.
- All installation and operation must comply with local electrical standards.
- Check all power cables and communication cables carefully.

System Start Up:

When the inverter is connected to the PV and the grid and both are operating normally, turn on the battery DC Switch. Press the POWER Switch and hold it for 3 seconds, then release. The Status LED is blinking green and indicates that the system is working normally.

System Shut Down:

Press and hold the POWER Switch for at least 5 seconds until all of the main battery LEDs (BMS Status LED and SOC LED) begin blinking. Once they start blinking, release the switch. The lights will automatically turn off after 5 seconds. Then, turn off the DC Switch.

System Black Start:

Under special circumstances when both PV and Grid power are out of order, the battery can be activated through the "Black Start" function. This means that our energy storage inverter and battery can continue to operate. The startup steps for Black Start are as follows:

- Turn on the DC Switch, press and hold the "POWER" button for 3 seconds, then release.
- Press the "POWER" button three times in succession within 4 seconds (Complete within 30 seconds after the battery system starts up).
- The Status LED remains solid green, indicating successful activation of Black Start mode.

Note: Ensure correct battery-inverter connection prior to Black Start. No wiring modifications during black start.

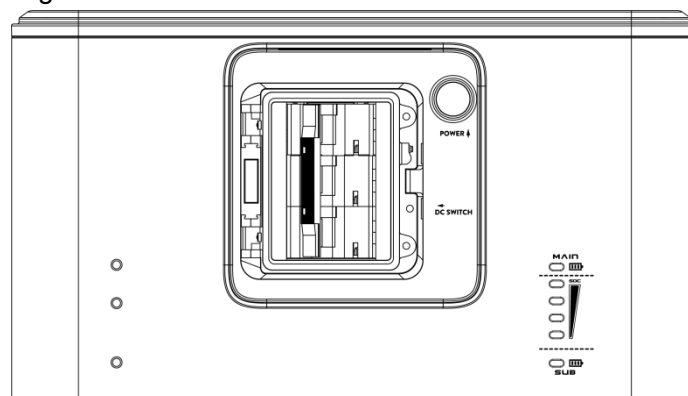

8.7 Disassembly Steps

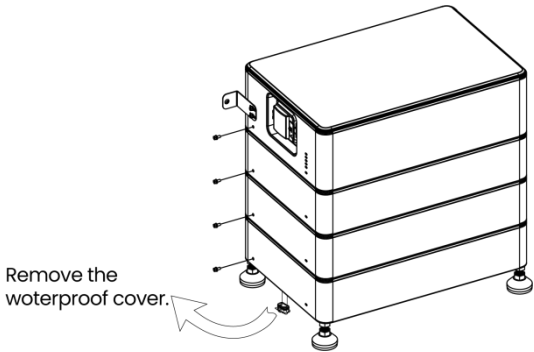
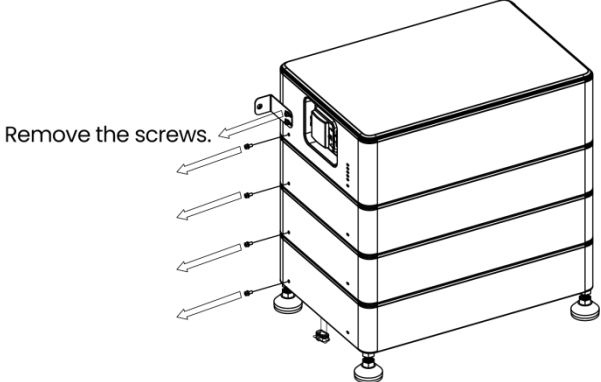
Procedures		
<p>Step 1</p>	<p>Shut down the battery system Press and hold the POWER Switch for at least 5 seconds until all of the main battery LEDs (BMS Status LED and SOC LED) begin blinking. Once they start blinking, release the switch. The lights will automatically turn off after 5 seconds. Then, turn off the DC Switch. Then, disconnect the wiring harness connected to the inverter.</p>	
<p>Step 2</p>	<p>Remove the waterproof cover.</p>	
<p>Step 3</p>	<p>Remove the screws (refer to Step 7 and Step 8 in Section 8.4).</p>	

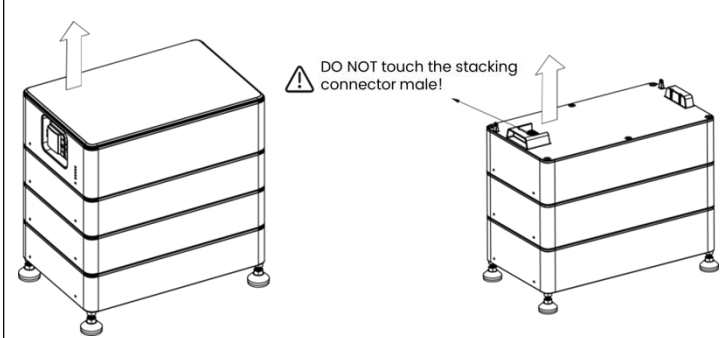
<p>Step 4</p>	<p>Remove the CQ7-M-50/CQ7-M-50 (w)/CQ7-M/CQ7-M (w) and CQ7-S-50/CQ7-S-50 (w)/CQ7-S/CQ7-S (w) modules, and store them properly according to the manufacturer's storage requirements.</p>	 <p>DO NOT touch the stacking connector male!</p>
----------------------	--	---

9 Commissioning

9.1 Monitoring Methods

Once the system has been successfully installed and commissioned, communication between the battery and the inverter is functioning correctly, and the battery can be monitored and controlled by the inverter. End users can view the monitoring page via the FoxCloud APP or the FoxCloud Web platform.

Battery system cable layout diagram

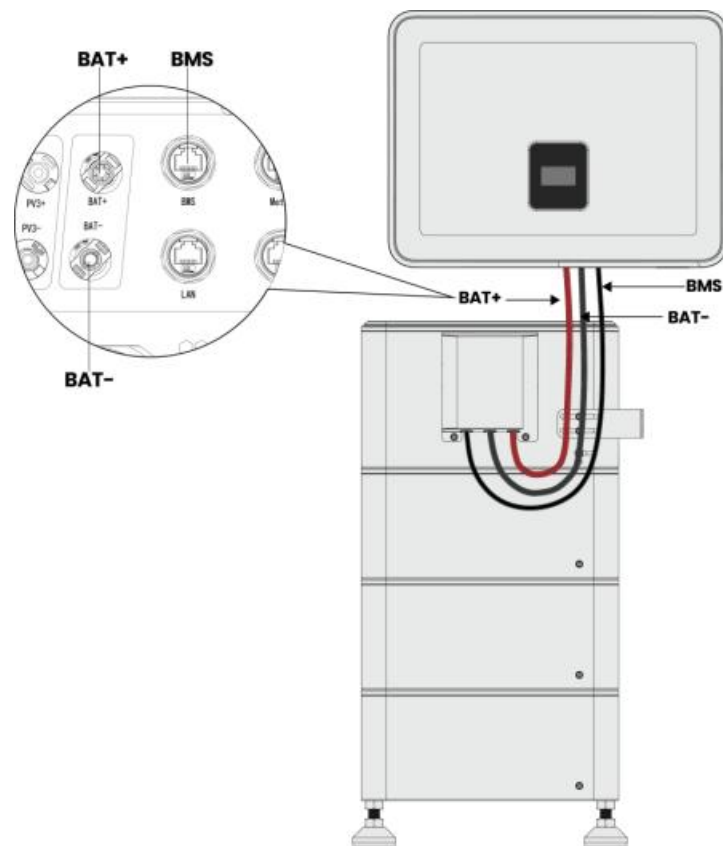

Note:

- Detailed information about the FoxCloud APP, please refer to the 《FoxCloud APP User Manual》.
- Detailed information about the FoxCloud Web platform, please refer to the relevant inverter manual.
- Terminal layout may vary between different inverters; the diagram above is for reference only. The actual wiring should be carried out in accordance with the manual for the specific inverter being used.

FoxCloud APP interface example

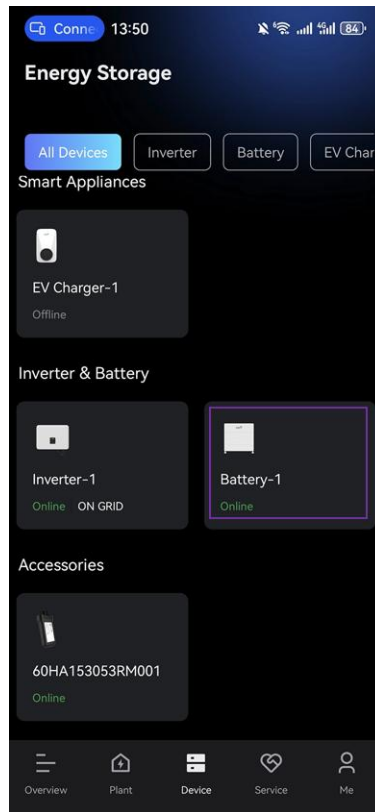

FoxCloud Web platform interface example

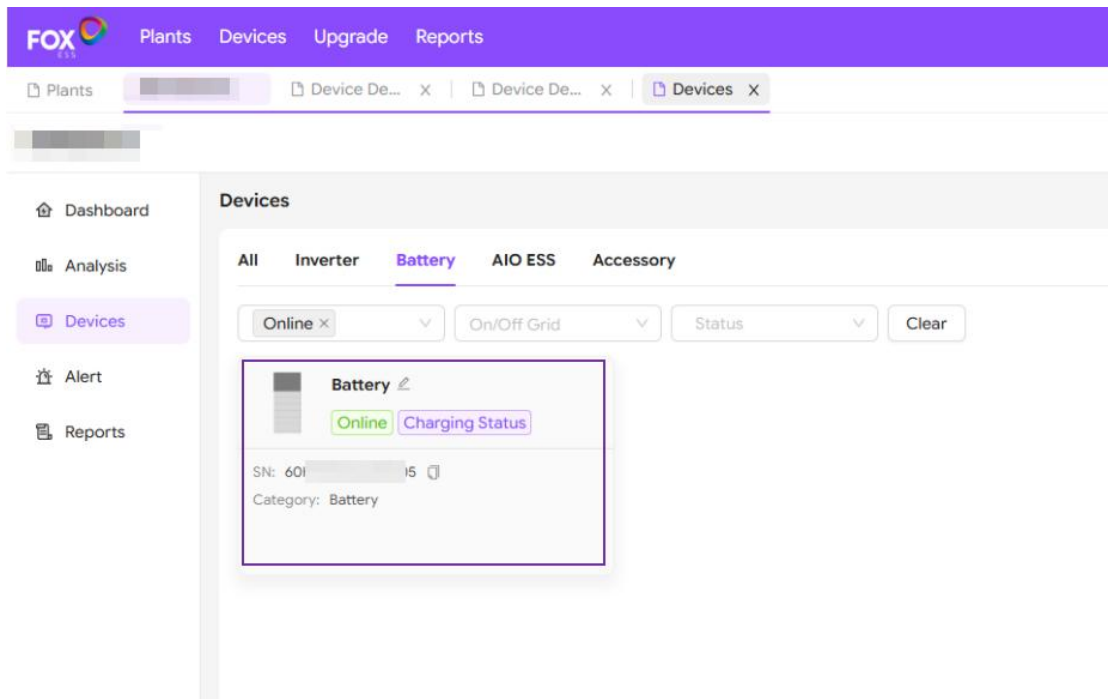

Note: The equipment details shown in the images above are for reference only.

The operating status light on the left side of the battery pack shows its working status.

For CQ7-S-50/CQ7-S-50 (w)/CQ7-S/CQ7-S (w)

Green LED	Red LED	Batteries Status
On for 0.5s, Off for 0.5s	On for 0.5s, Off for 0.5s	Running in boot
On for 0.1s, Off for 0.1s	On for 0.1s, Off for 0.1s	Upgrading
On for 1s, Off for 1s	Off	Normal Working
Off	On for 1s, Off for 1s	Alarm

For CQ7-M-50/CQ7-M-50 (w)/CQ7-M/CQ7-M (w)

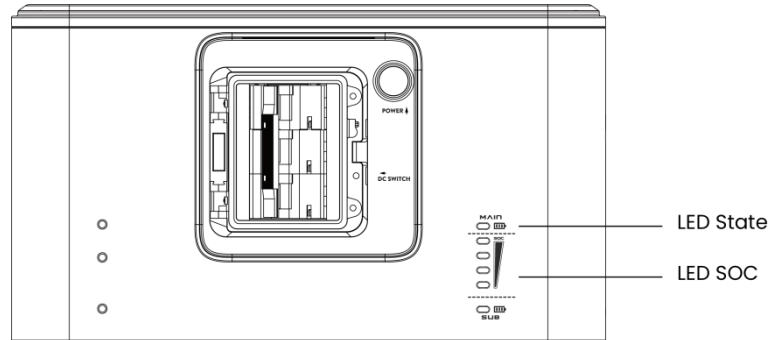

SOC	System Status	LED State	LED SOC				
=100%	Standby	■	●	●	●	●	●
100% > SOC >= 75%		■	●	●	●	●	●
75% > SOC >= 50%		■	/	●	●	●	●
50% > SOC >= 25%		■	/	/	●	●	●
25% > SOC >= 0%		■	/	/	/	/	●
=100%	Discharge	●	●	●	●	●	●
100% > SOC >= 75%		●	●	●	●	●	●
75% > SOC >= 50%		●	/	●	●	●	●
50% > SOC >= 25%		●	/	/	●	●	●
25% > SOC >= 0%		●	/	/	/	/	●
=100%	Charge	●	■	■	■	■	■
100% > SOC >= 75%		●	■	■	■	■	■
75% > SOC >= 50%		●	/	■	■	■	■
50% > SOC >= 25%		●	/	/	■	■	■
25% > SOC >= 0%		●	/	/	/	/	■

Fault	LED State	LED SOC			
Under voltage fault	■	/	/	/	●
Over voltage fault	■	/	/	●	/
Over temperature fault	■	/	/	●	●
Under temperature fault	■	/	●	/	/
Discharge over current	■	/	●	/	●
Charge over current	■	/	●	●	/
Warm up film switch adhesion	■	/	●	●	●
Reserve	■	●	/	/	/
Pre-Charge failed	■	●	/	/	●
Short circuit Protection	■	●	/	●	/
AFE communication failed	■	●	/	●	●
Module Addressing failed	■	●	●	/	/
IVU Communication failed	■	●	●	/	●
BMU Communication failed	■	●	●	●	/
PCS Communication failed	■	●	●	●	●
HVB FUSE fault	●	/	/	/	●
Module FUSE fault	●	/	/	●	/
Module matching fault	●	/	/	●	●
Internal total voltage sampling failed	●	/	●	/	/
Temperature sampling failed	●	/	●	/	●
Relay adhesion	●	/	●	●	/
Relay Not Close	●	/	●	●	●
Relay drive failed	●	●	/	/	/
Single Cell "0V" fault	●	●	/	/	●
Temperature high permanent failed	●	●	/	●	/
The Single voltage high permanently failed	●	●	/	●	●
SOH low protection	●	●	●	/	/
AFE failed (UV/OV/UT/OT)	●	●	●	/	●
Shutdown failed	●	●	●	●	/
Other fault	●	●	●	●	●

Remark:

■: LED flash display (on: 0.5s, off: 0.5s)

●: LED on display

10 Exclusion

The warranty shall not cover the defects caused by normal wear and tear, inadequate maintenance, handling, storage faulty repair, modifications to the battery or pack by a third party other than Fox ESS or Fox ESS agent, failure to observe the product specification provided herein or improper use or installation, including but not limited to the following.

- Damage during transport or storage.
- Incorrect Installation of battery into pack or maintenance.
- Use of battery pr pack in inappropriate environment.
- Improper, inadequate, or incorrect charge, discharge or production circuit other than stipulated herein.
- Incorrect use or inappropriate use.
- Insufficient ventilation.
- Ignoring applicable safety warnings and instructions.
- Altering or attempted repairs y unauthorized personnel.
- In case of force majeure (ex: lightning, storm, flood, fire, earthquake, etc.).
- There are no warranties-implied or express-other than those stipulated herein. Fox ESS or Fox ESS shall not be liable for any consequential or indirect damages arising or in connection with the product specification, battery or pack.

11 Troubleshooting and Maintenance

11.1 Maintenance

- Regularly check whether the service environment of the battery meets the requirements, and the installation position should be far away from the heat source.
- The battery module should be stored in an environment with a temperature range between -20°C- +55°C, and charged regularly according to the table below with no more than 0.5 C(A C-rate is a measure of the rate at which a battery is discharged relative to its maximum capacity.) to the SOC of 50% after a long time of storage.

Storage environment temperature	Relative humidity of the storage environment	Storage time	SOC
Below -20°C	/	Not allowed	/
-20~0°C	10%~90%	≤ 1 months	20%≤SOC≤50%
0~35°C	10%~90%	≤ 6 months	20%≤SOC≤50%
35~55°C	10%~90%	≤ 1 months	20%≤SOC≤50%
Above 55°C	/	Not allowed	/

Note: If the battery is stored over one year, 5%- 8% of the capacity may lose irreversibly.

- Regularly check whether the battery and its supporting terminals, connecting cables and indicator lights are normal.

Expanded capacity requirement

If a battery is replaced or added for capacity expansion, each battery's SOC should be consistent. The max. SOC difference should be between ±5%.

If users want to increase their battery system capacity, please ensure that the SOC of the existing system capacity is about 50%. The manufacturer date of the new battery shall not exceed 12 months; in case of exceeding 12 months. please charge the new battery to around 50%.

11.2 Storage with Low SOC

After the product is powered off, static power consumption and self-discharge loss may occur in internal modules. Therefore, charge batteries in a timely manner and do not store the product in low SOC. Otherwise, the product may be damaged due to overdischarge, and battery modules need to be replaced.

Storage in low SOC may occur in the following scenarios:

- The DC SWITCH on the power control module is OFF.
- The power cables or signal cables are not connected.

- The batteries cannot be charged due to a system fault after discharge.
- The batteries cannot be charged due to incorrect configurations in the system.
- The batteries cannot be charged due to no PV input and long-term mains failure.

Regardless of scenarios, the batteries must be charged within the longest interval corresponding to the SOC when the batteries are powered off. If the batteries are not charged within the specified interval, they may be damaged due to overdischarge.

Storage environment temperature	Power-Off SOC Before Storage	Maximum Charge Interval
0~35°C	0% ≤ SOC < 5%	7 days

Note: When the battery SOC decreases to 0%, charge the batteries within seven days. Permanent battery faults caused by delayed charge due to customer reasons are beyond the warranty scope.

11.3 Troubleshooting

When the red / green LED on the panel is flashing or normally on, it does not mean that the CQ7 is abnormal, it may be just an alarm or protection. Please check the “LED status indicators” in chapter 9 for the detailed faulty definition before any troubleshooting steps. In general, the alarm indication is normal without manual intervention. When the alarm triggering state is removed, CQ7 will automatically return to normal use.

Problem determination based on the following points:

- Check if the red indicator light illuminates once the battery enters operation;
- Whether the buzzer in CQ7-M-50/CQ7-M-50 (w)/CQ7-M/CQ7-M (w) on;
- Whether the battery system can be communicated with inverter;
- Whether the battery can be output voltage or not.

Preliminary determination steps

Battery system cannot work, when DC switch on and POWER on, the LED doesn't light up or flash, please contact the local distributor.

- The LED display of CQ7-M-50/CQ7-M-50 (w)/CQ7-M/CQ7-M (w) and CQ7-S-50/CQ7-S-50 (w)/CQ7-S/CQ7-S (w) is normal, but it cannot charge and discharge. Observe the display screen of inverter and there is no SOC. Please check whether the CAN communication between CQ7-M to inverter is well connected. If the connection is good, please replace a CAN communication cable. If the SOC is still not visible on the inverter display screen, please contact the local distributor.
- After the battery system is powered on, if you can see the alarm information on the LED and inverter display screen at the same time, please contact the local distributor.

11.4 Low-Temperature Battery Reserve

To prevent battery drain and potential damage in freezing weather, the system includes an automatic low-temperature protection feature. It proactively manages the battery to maintain adequate charge, extending standby time when temperatures drop.

12Appendix

12.1 Quality Guarantee

FOXESS CO., Ltd. (hereinafter referred to as "the Company") will, for products found to be faulty during the warranty period, repair the product free of charge or replace it with a new one.

Supporting Documentation Required

When requesting warranty service, the customer must present the original purchase invoice indicating the date of purchase. Furthermore, the product's trademark must be clearly visible. The Company reserves the right to decline warranty coverage if these conditions are not met.

Relevant Conditions

- Non-conforming products replaced under warranty shall be disposed of by the Company.
- The customer must allow the Company a reasonable period of time to complete repairs on faulty equipment.

Warranty Exclusions

The Company reserves the right to decline warranty coverage under the following circumstances:

- The entire machine or specific components have exceeded the free warranty period.
- Damage incurred during transportation.
- Faults resulting from incorrect installation, modification, or use.
- Operation in environments that exceed the limits specified as harsh in this manual.
- Malfunctions or damage caused by installation, repair, alteration, or disassembly performed by service organizations or personnel not authorized by the Company.
- Use or installation outside the scope defined in the relevant international standards.
- Damage caused by abnormal natural disasters.
- Damage resulting from storage conditions that do not meet the requirements stated in the product documentation.
- Any losses arising from failure to adhere to the safety precautions outlined in this manual.

If a product failure is caused by any of the above circumstances and the customer still requests repair services, the Company's authorized service organization may, upon assessment, provide repair services subject to a charge.

Other Provisions

The Company reserves the right to change product dimensions and parameters based on its latest documentation without prior notice.

12.2 Contact Us

If you have any questions about the product, please contact us:

- Fox ESS Headquarters: No.939, Jinhai Third Road, New Airport Industry Area, Longwan District, Wenzhou, Zhejiang, China.
- Wuxi R&D Center: No. 97 Huaqing Avenue, Wuxi Economic Development Zone (Intersection of Huaqing Avenue and Huayun Road)
- Wuhan R&D Center: 6th Floor, Block A, Tower T4, CHINA PROCUREMENT CENTER, No. 789 Gaoxin Avenue, East Lake New Technology Development Zone, Wuhan City, Hubei Province, P.R. China
- Shanghai R&D Center: No.1255, Jinhai Road, Pudong New Area, Shanghai, China
- After-Sales Service Hotline: 400 1888 900
- Contact Telephone (Wenzhou): 0577-88159999
- Contact Telephone (Wuxi): 0510-68092998
- Contact Us: info@fox-esscom
- Contact Us (EV Charger): ev@fox-esscom
- After-Sales Service: service@fox-esscom