

# EP6/EP12 | EK6/EK12 + INVERTER COMPATIBILITY LIST

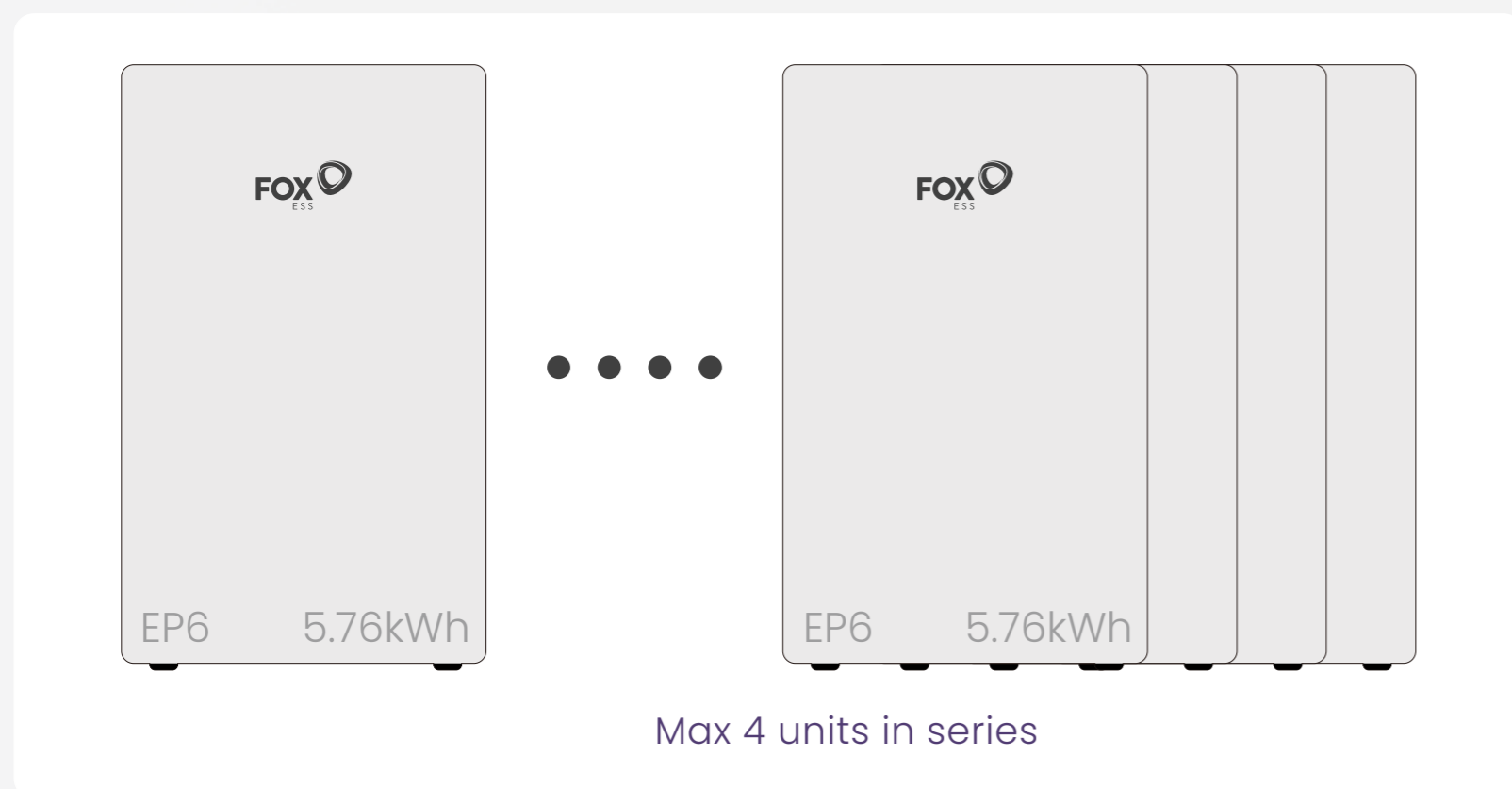

- IP65 rating for outdoor use, resistant to harsh weather.
- Built-in fire protection module, ensuring safety and reliability
- Built-in heating function for reliable winter operation (optional).
- Modular design for flexible capacity expansion.
- Premium LiFePO<sub>4</sub> cells and full aluminum die-cast housing for superior safety and reliability.

Series	EP6/EP12 (Battery Qty Min.-Max.)	Inverter	
		Single Phase System	EP6/EP12 - 4*(EP6/EP12)
KH			
Three Phase System	EP6/EP12 - 4*(EP6/EP12)	H3 SMART	P3-S
		H3-M	
	[EP6/EP12 - 4*(EP6/EP12)] *2	H3 PRO	P3 PRO

\* EP6/EP12 is sold worldwide.  
\* EK6/EK12 is sold only in Germany.

\* H3 SMART/H3 PRO version is applicable to: Australia | Austria | Germany | Italy | Switzerland | UK  
\* P3-S/P3 PRO version is applicable to: Some other markets not covered by H3 SMART/H3 PRO

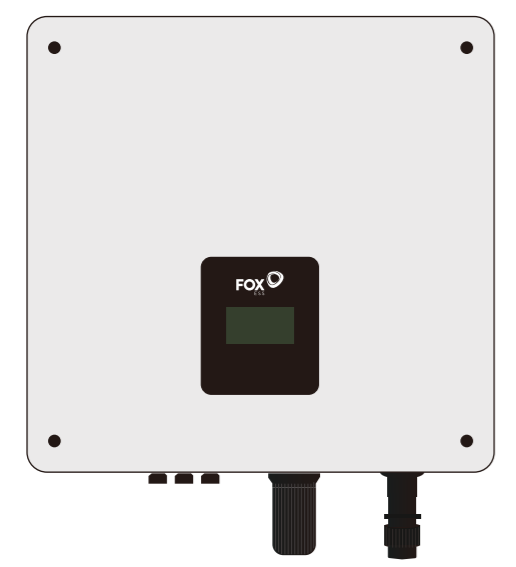

5.76kWh

Single

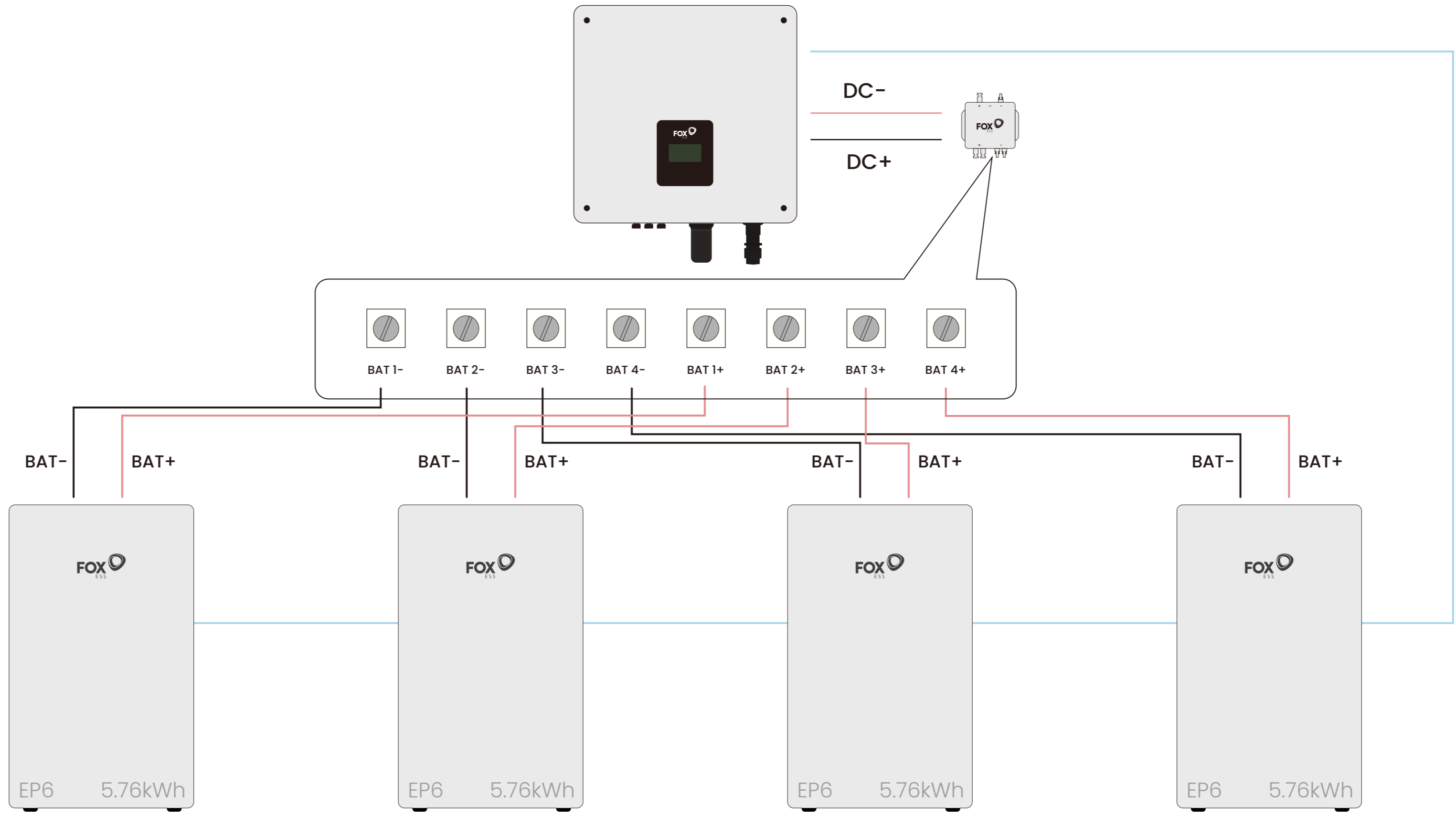

23.04kWh

Parallel

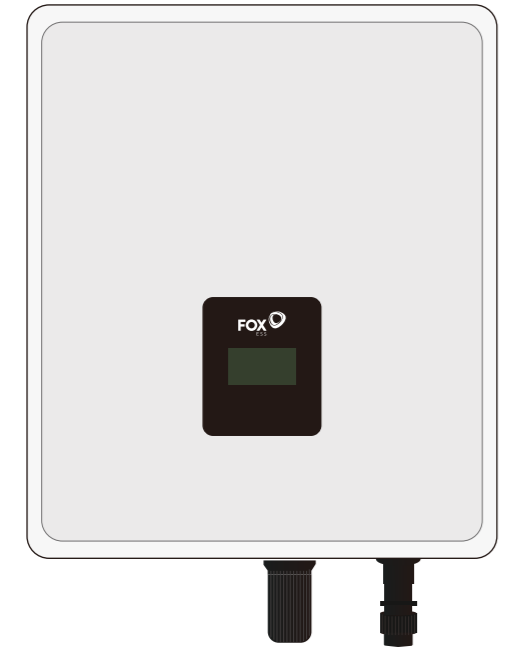

5.76kWh

Single

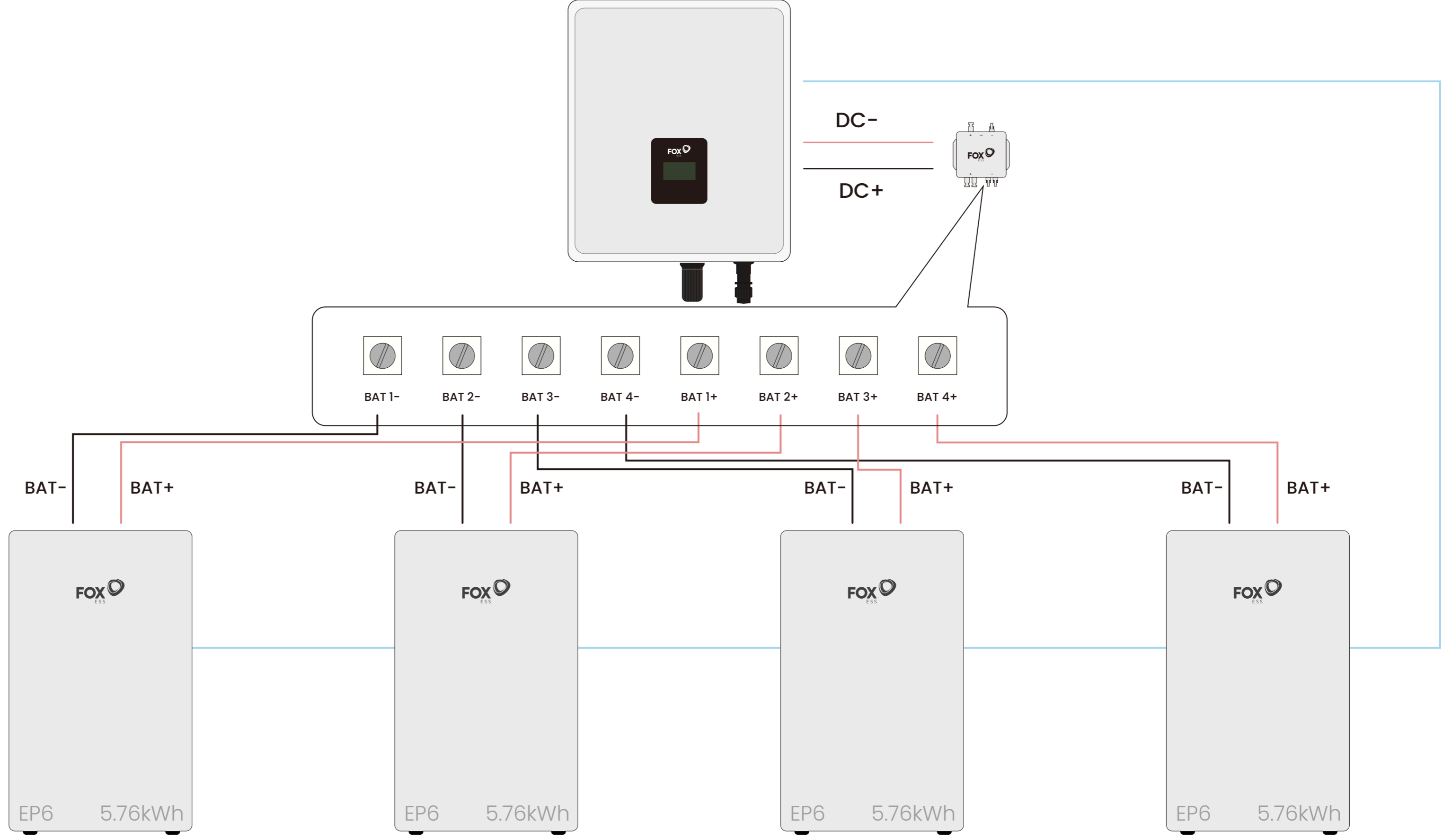

23.04kWh

Parallel

H3 SMART(5~15kW) / H3-M(5~15kW)  
P3-S(5~15KW)

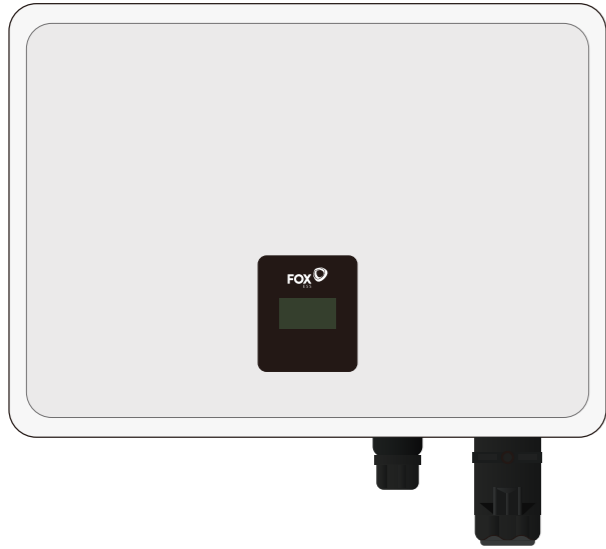

5.76kWh

Single

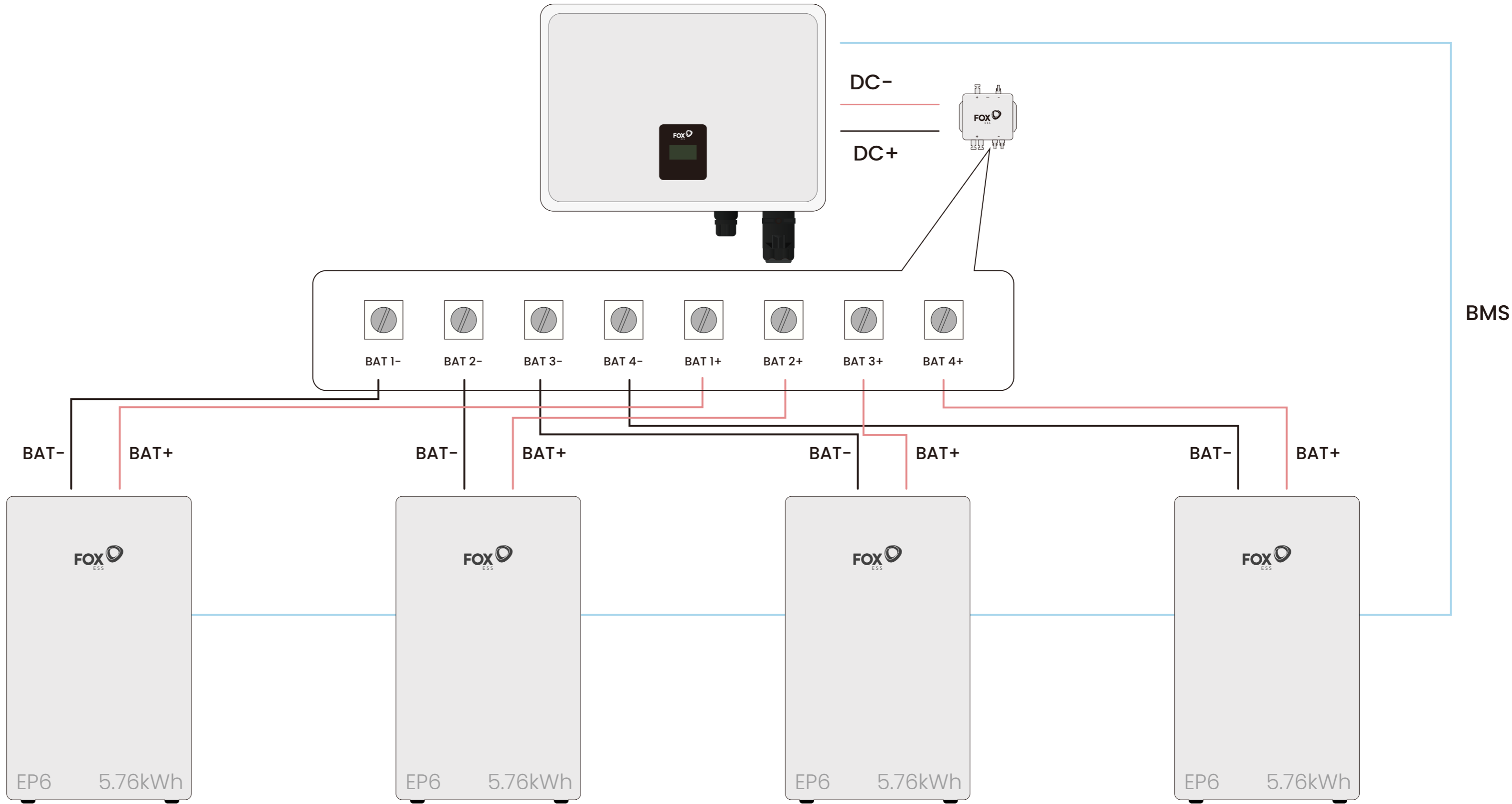

23.04kWh

Parallel

H3 PRO(15~30KW)  
P3 PRO(15~30KW)

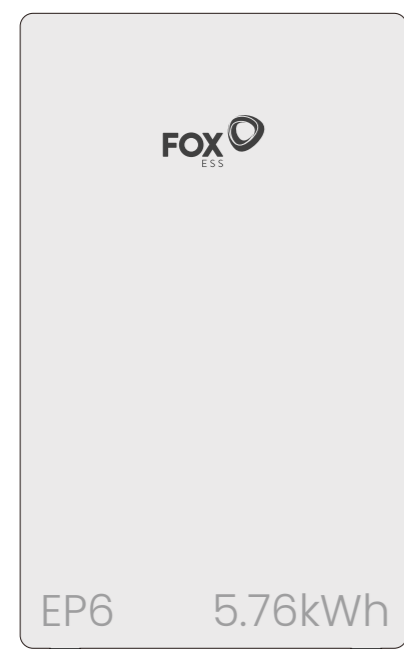
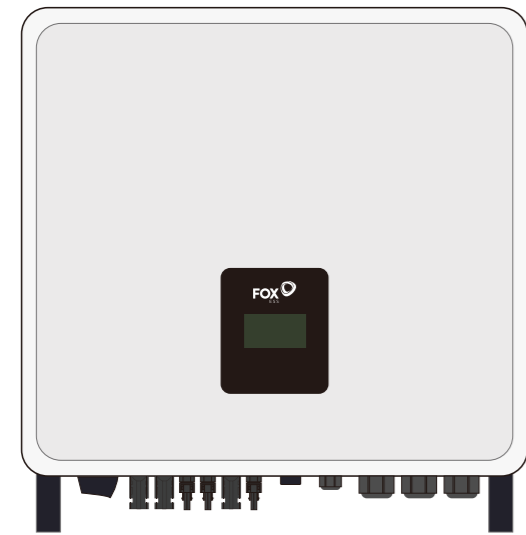

5.76kWh

Single

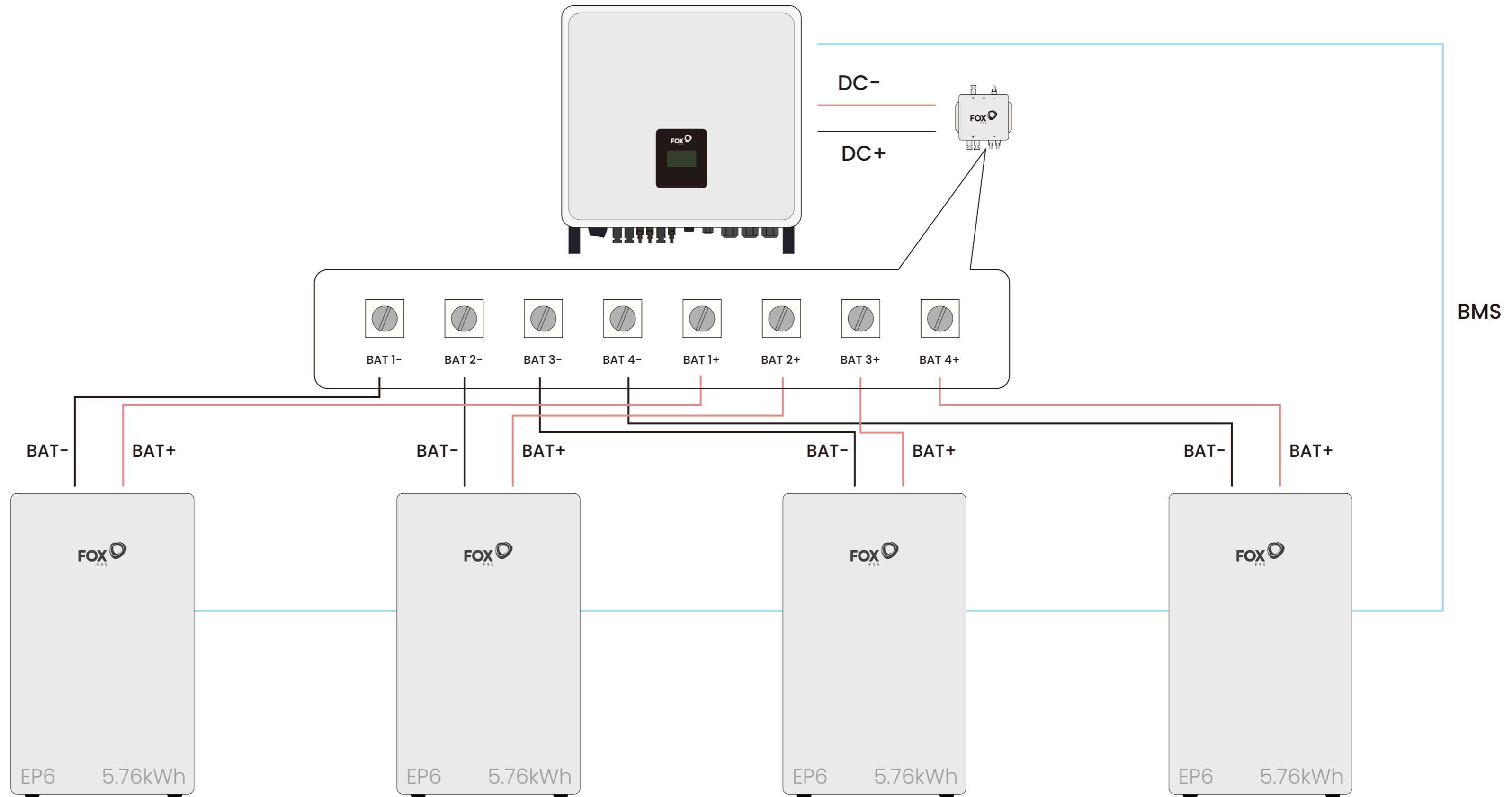

23.04kWh

Parallel

H3 PRO(15~30KW)  
P3 PRO(15~30KW)

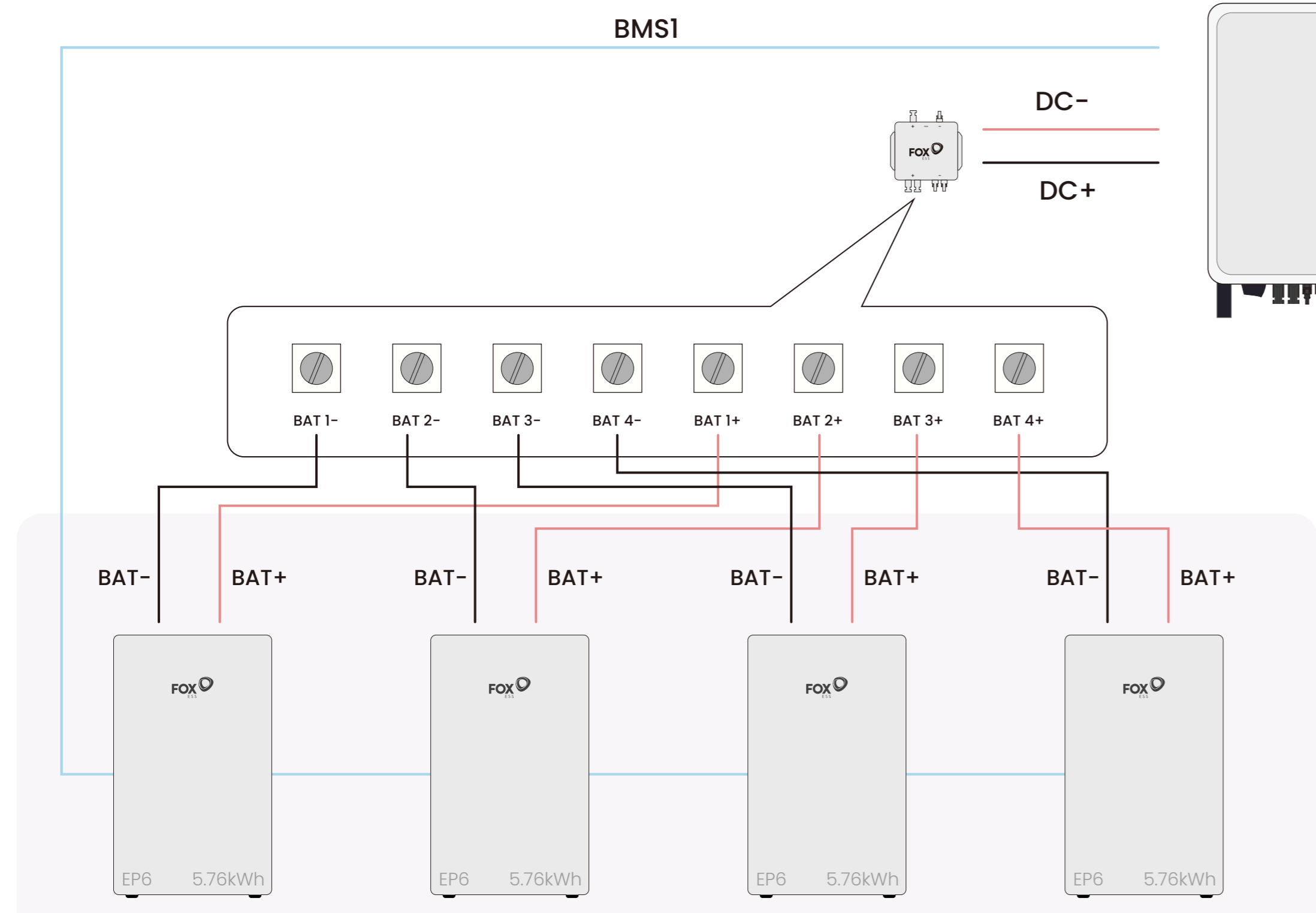

23.04kWh

**Note**  
BMS 1: MIN 1 units to MAX 4 units.

Parallel

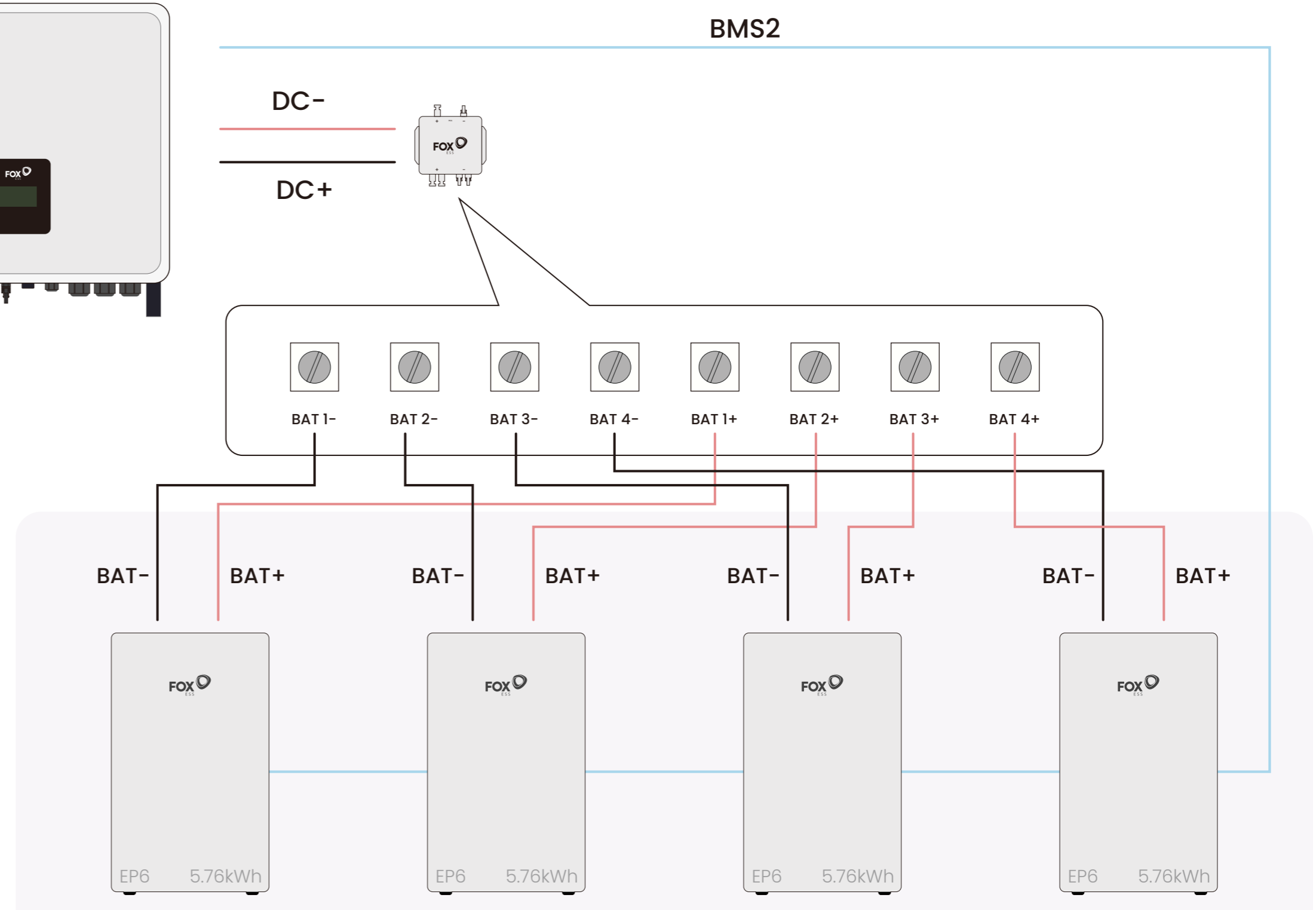

23.04kWh

**Note**  
BMS 2: MIN 1 units to MAX 4 units.

Parallel

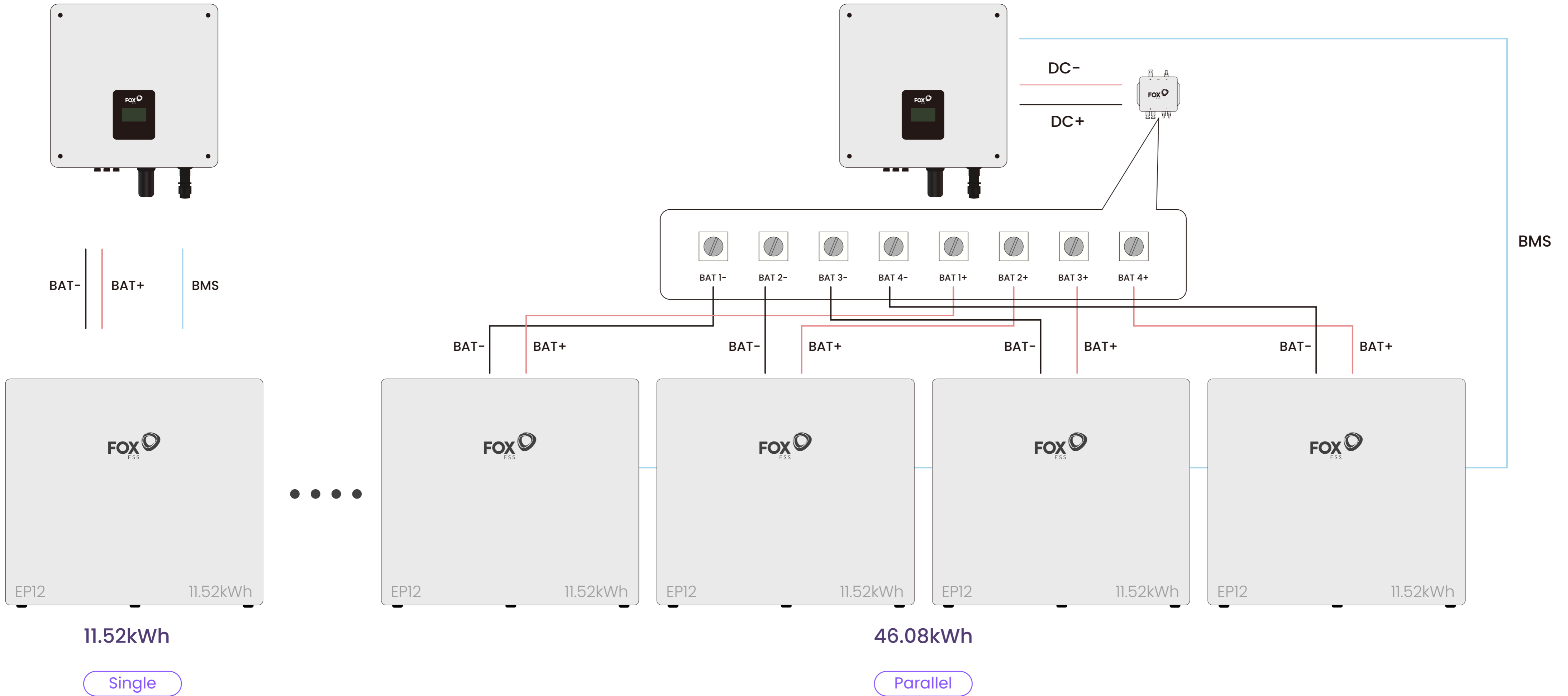

BMS

Single

Parallel

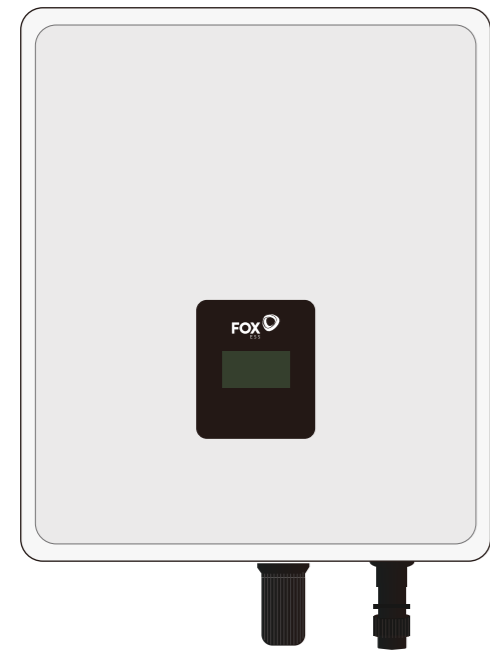

11.52kWh

Single

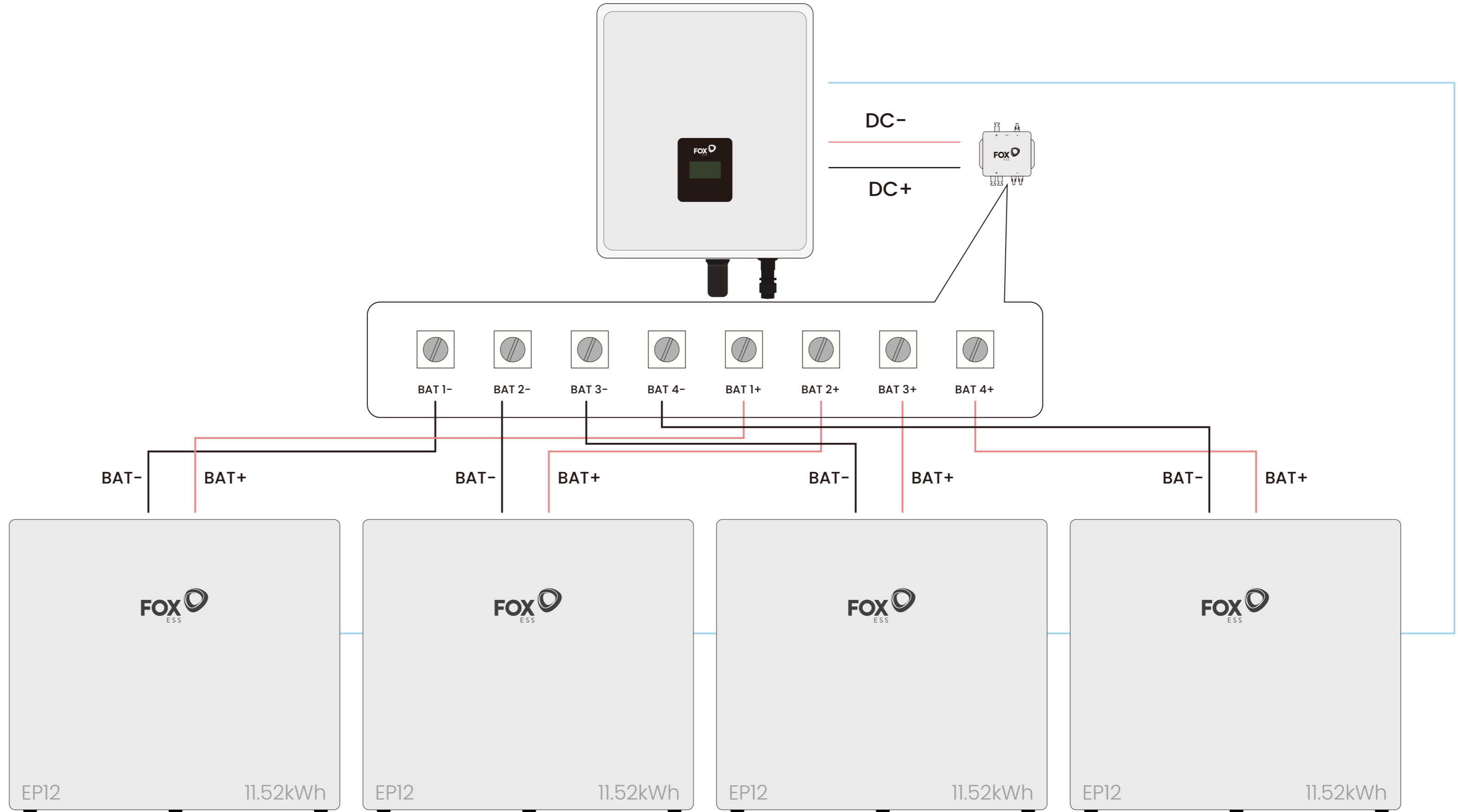

46.08kWh

Parallel

BMS

# EK12/EP12 + THREE PHASE SYSTEM

H3 SMART(5~15kW) / H3-M(5~15kW)  
P3-S(5~15KW)

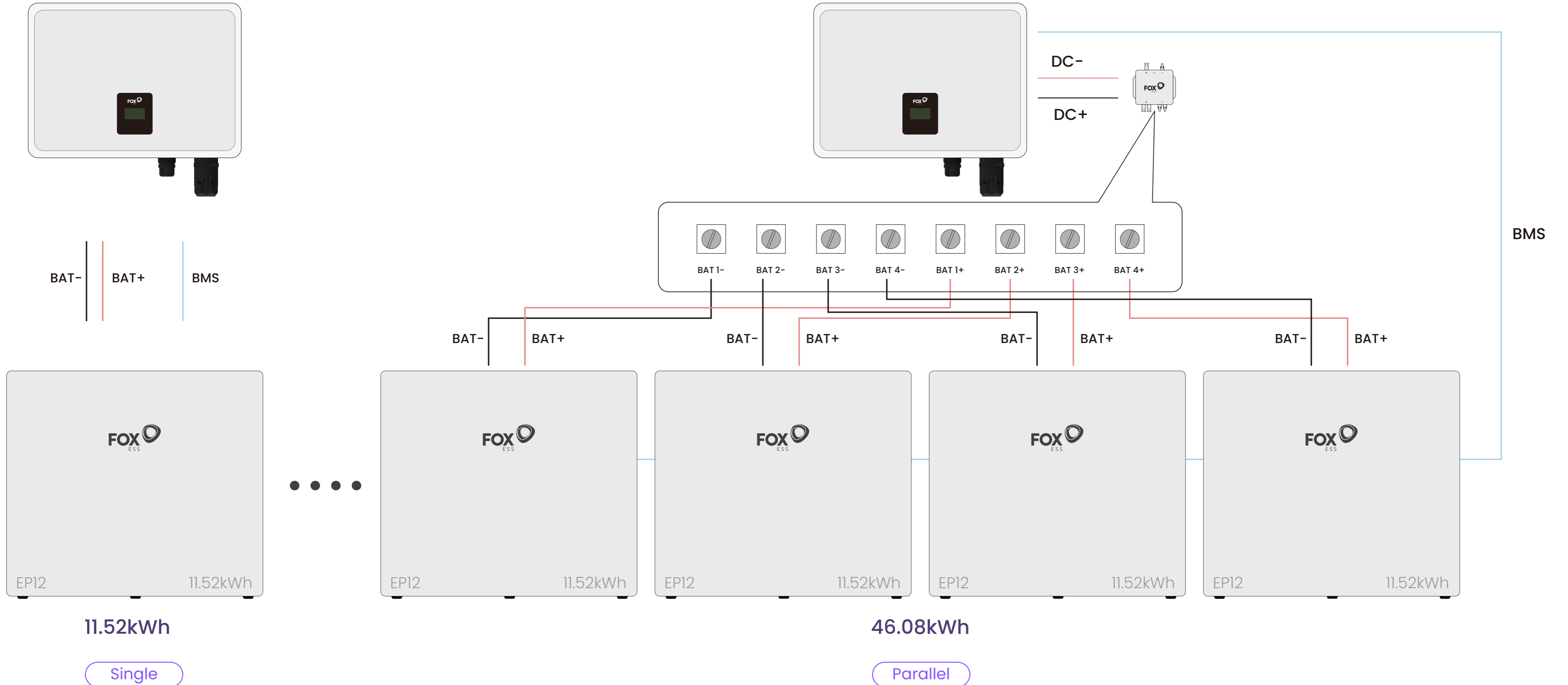

BMS

H3 PRO(15~30KW)  
P3 PRO(15~30KW)

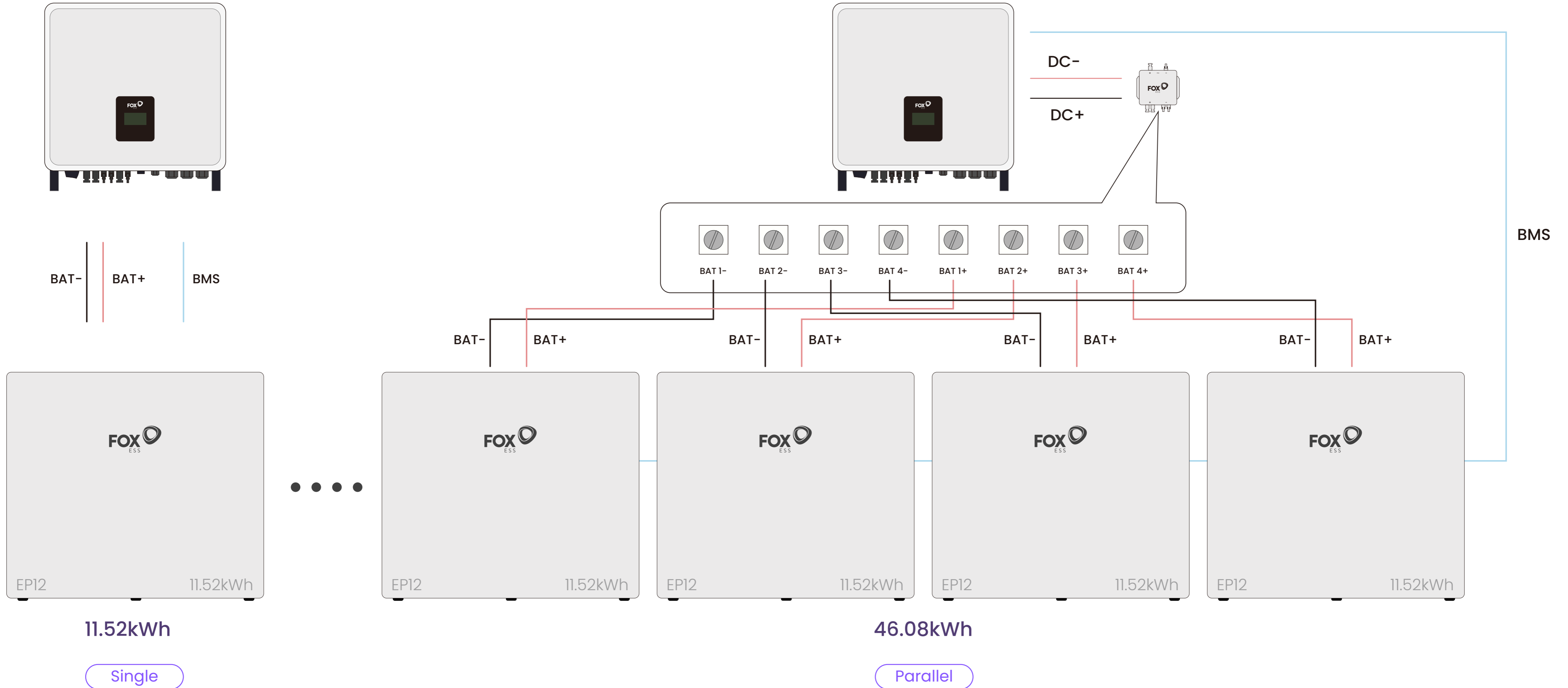

H3 PRO(15~30KW)  
P3 PRO(15~30KW)

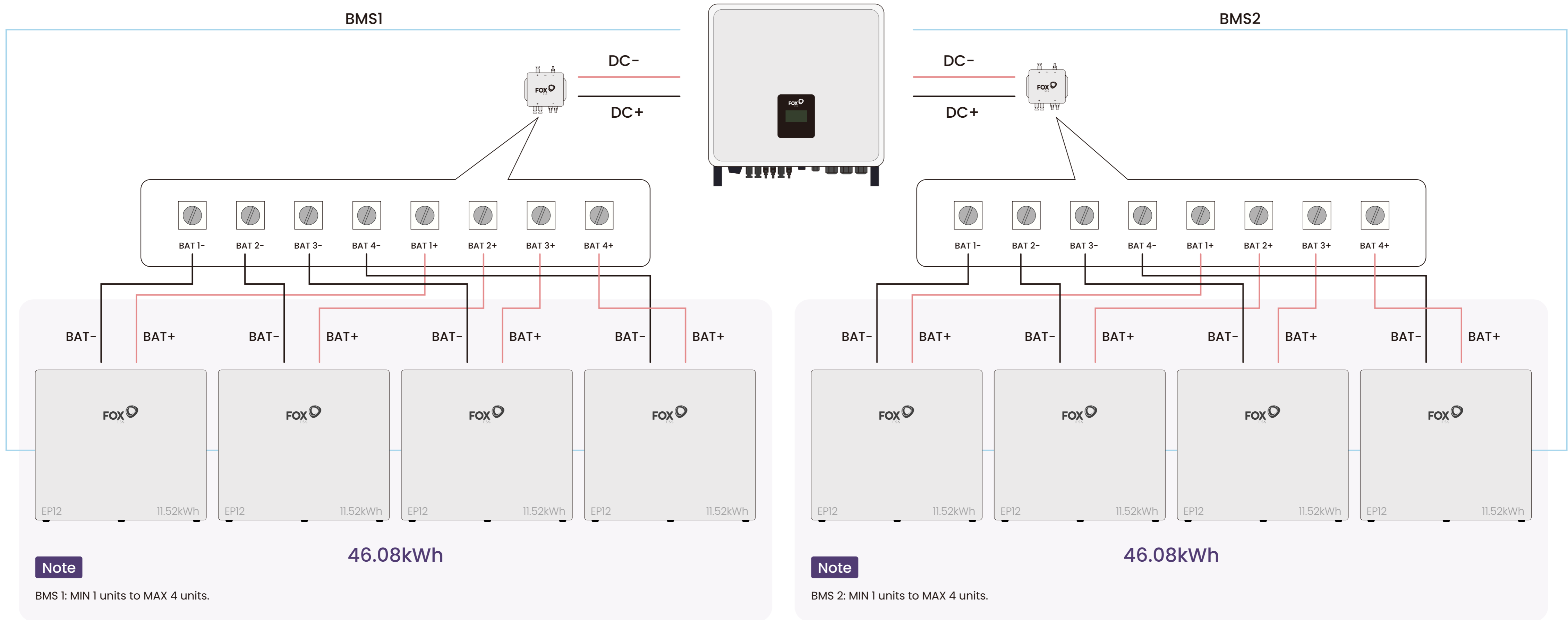

**Note**

BMS 1: MIN 1 units to MAX 4 units.

**Note**

BMS 2: MIN 1 units to MAX 4 units.

Parallel

Parallel

H3 PRO(15~30KW)  
P3 PRO(15~30KW)

BMS1

BMS2

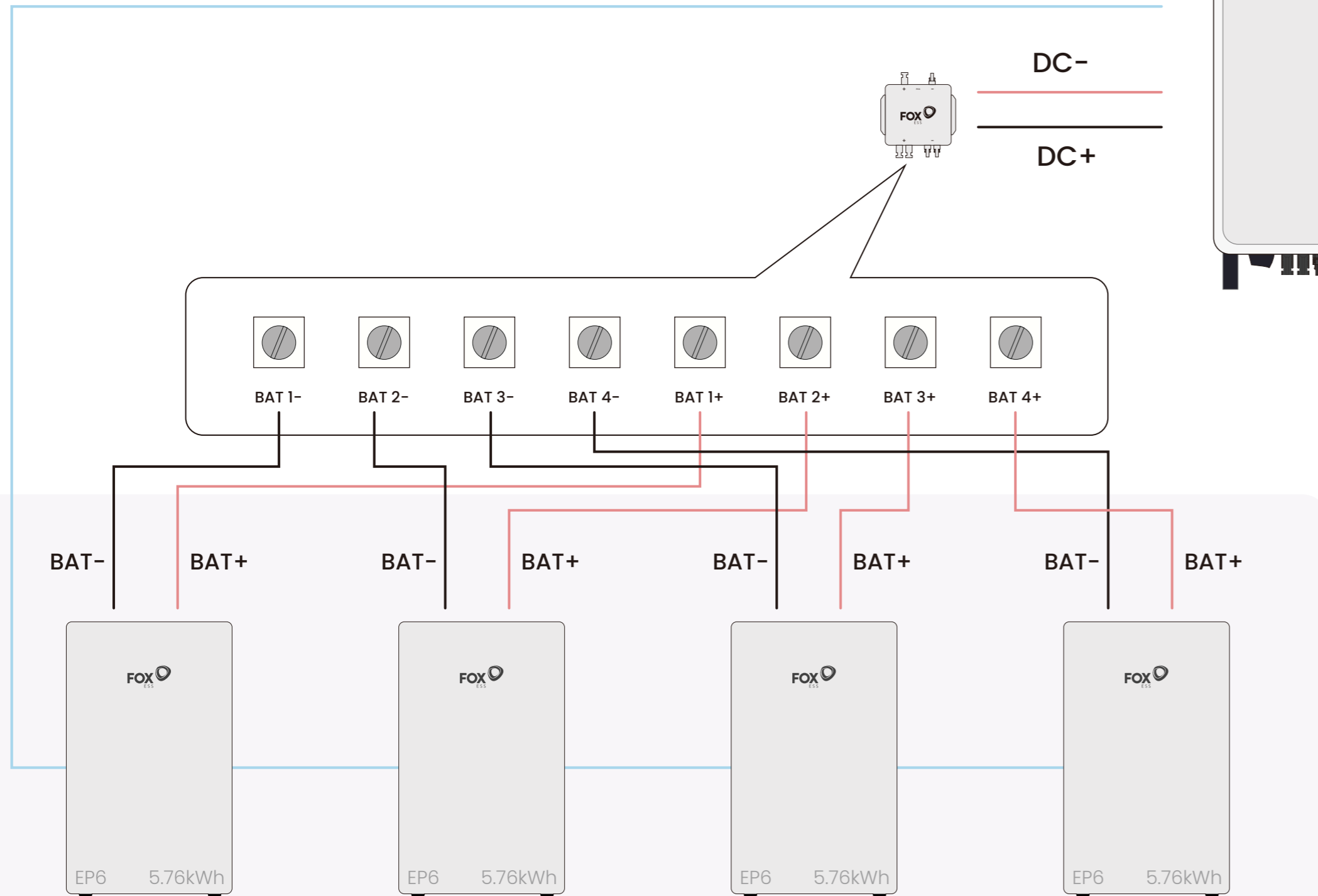
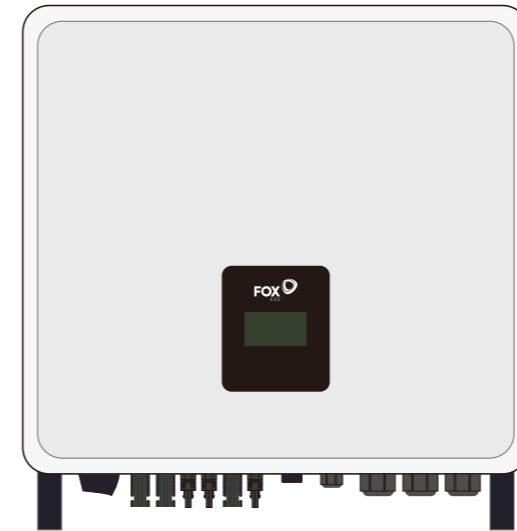

23.04kWh

**Note**

BMS 1: MIN 1 units to MAX 4 units.

Parallel

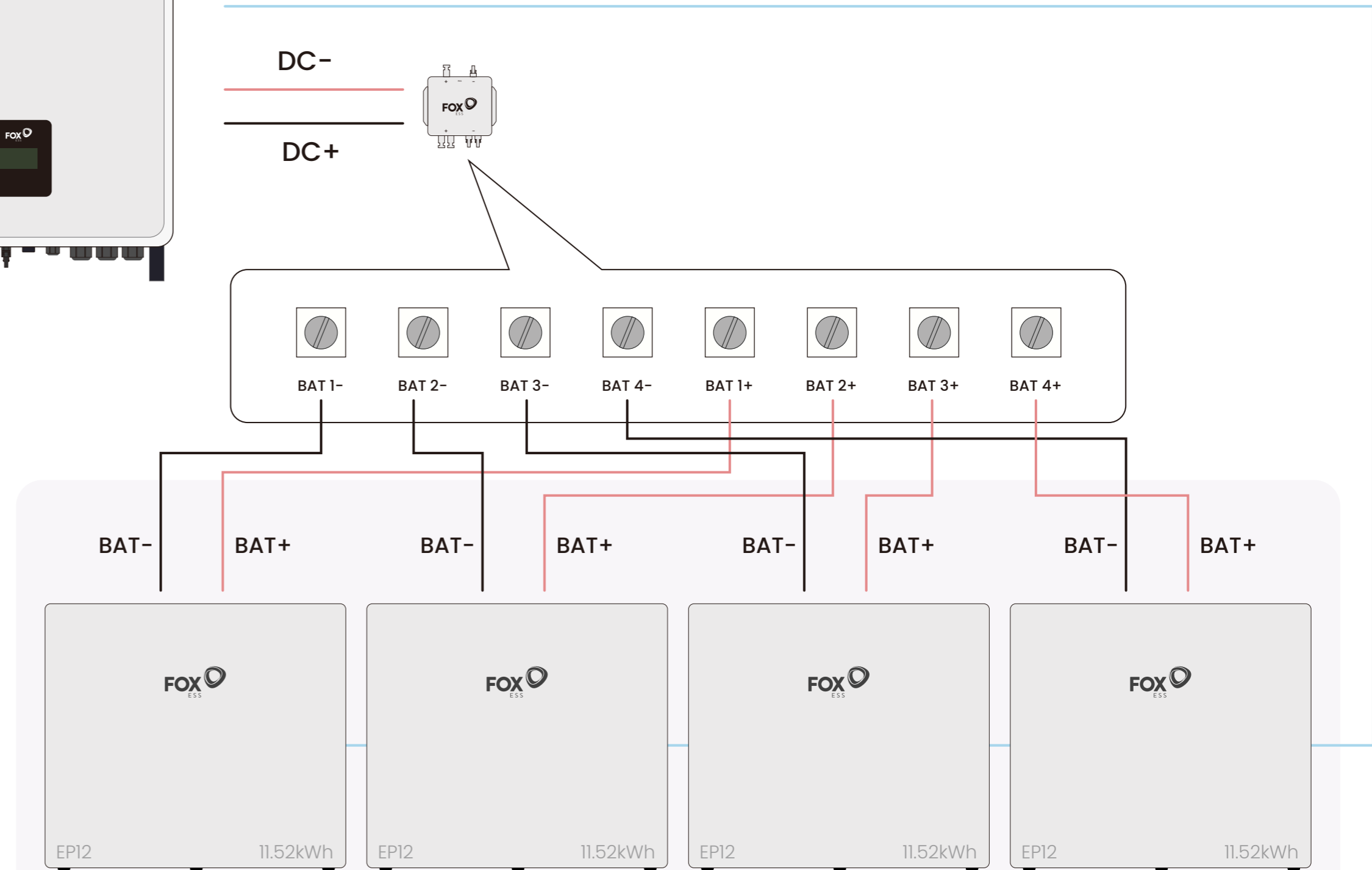

46.08kWh

**Note**

BMS 2: MIN 1 units to MAX 4 units.

Parallel